

SRI International S-band High Altitude Balloon Radar Experiment

This document describes SRI International's radar experiment and the need for Special Temporary Authority (STA) license through the FCC.

Experiment Overview

SRI is planning to test an experimental S-band radar system on an airplane. The radar tests are expected to take place between the June 11th and July 31st in order to view the active volcanic activity around Mount Kilauea. This window allows for multiple flights of the instrument for repeat-pass measurements, as well as flight reschedules due to problems with weather or equipment malfunctions. The radar system is designed to generate interferometric synthetic aperture radar (InSAR) for the purpose of measuring ground deformation for various Earth Science applications. The eruption from Mount Kilauea provides a unique opportunity to evaluate the science potential of our radar system by imaging the actively subsiding summit and conduit collapse, processes that drive hazardous explosive eruptions and thus have a direct impact on the surrounding community. The radar system is built by SRI International and consists of a custom transmitter, receiver unit, and antenna unit.

The location of operation will be 20 miles centered on Mount Kilauea, HI. Operation will take place between 2000 ft and 12000 ft. The anticipated area of operation is between 19.11N to 19.7N latitude, and 154.97 W to 155.6 W longitude. The radar will operate periodically over the flight path, transmitting for 3 minutes about once every 10 minutes while aloft. Because the intent of the experiment is to image the ground, the radar antenna will always be pointed at an elevation angle below the horizon.

During the experiment, SRI operators will be able to disable the radar and/or radio transmitter at any time. Transmission of the radar and/or radio can be stopped by contacting either of the following SRI personnel:

- Lauren Wye: 650-678-9184
- Simon Lee: 805-801-9223

Radar Payload Description

The SRI radar consists of a custom S-band transmitter and receiver unit designed and built by SRI International. The radar transmits a pulsed linear FM chirp signal over **2.96-3.00GHz**, having an instantaneous BW of less than **40 MHz** bandwidth. The transmitter outputs the waveform with an average power of about 60 W. A 21 dBi gain antenna is used with the transmitter, resulting in an EIRP of 7500 W average. The radar will operate with a maximum pulse repetition frequency (PRF) of 4000 Hz, a maximum pulse width of 100 microseconds, and a duty cycle of 10%. The radar antenna has a beamwidth of 10 deg in the azimuth (horizontal) plane and 27 deg in the elevation plane. The directive antenna will be pointed at a depression angle between 10 and 70 deg below the horizon. Figure 5 shows a schematic of the SRI S-band radar system. Prior to the aircraft taking off, the radar will be tested on the ground at a regional airport near Mount Kilauea, HI.

The radar transmitter has the following emission mask, which was measured in the laboratory with a spectrum analyzer at 1 MHz resolution bandwidth

- -3 dB bandwidth: 42 MHz
- -20 dB bandwidth: 50 MHz
- -40 dB bandwidth: 60 MHz
- -50 dB Bandwidth: 70 MHz

Spurious and harmonic emission measurements were also made of the radar transmitter outputs:

- Spurious emissions over 2.96 to 3.0 GHz: -40 dBc
- Spurious emissions out of band: -60 dBc
- Harmonics: -40 dBc

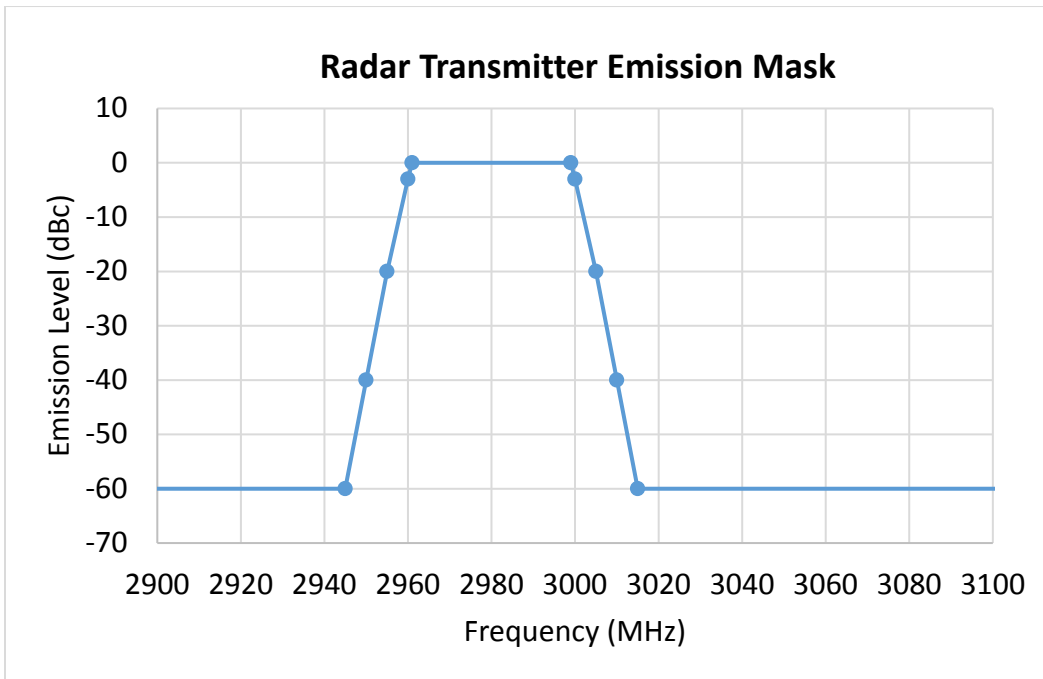

Figure 1. Radar Transmitter Emission Mask

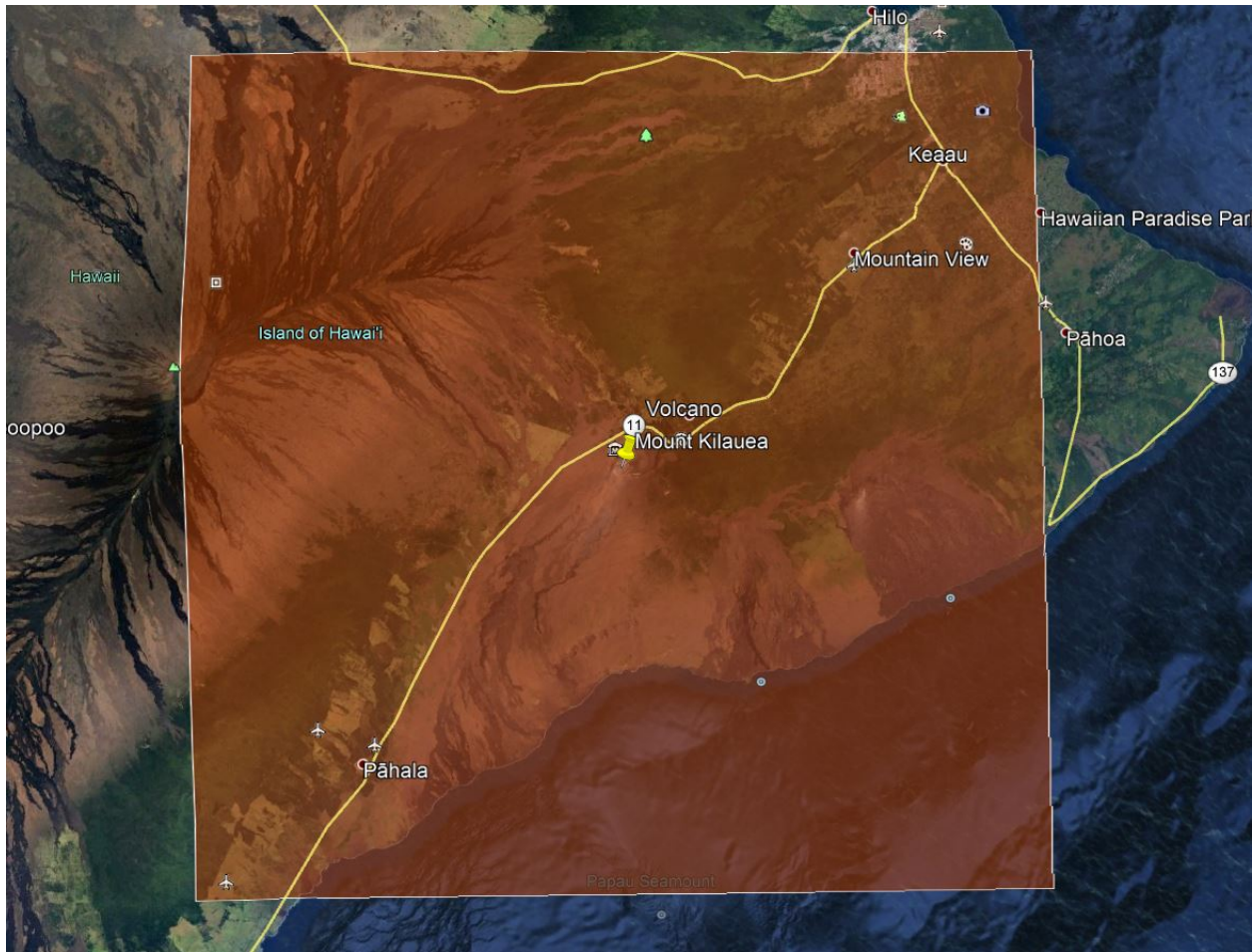

Figure 2. Area of operation Mount Kilauea, HI, altitudes between X and Y ft over 19.11 N to 19.7 N, 154.97 W to 155.6 W.

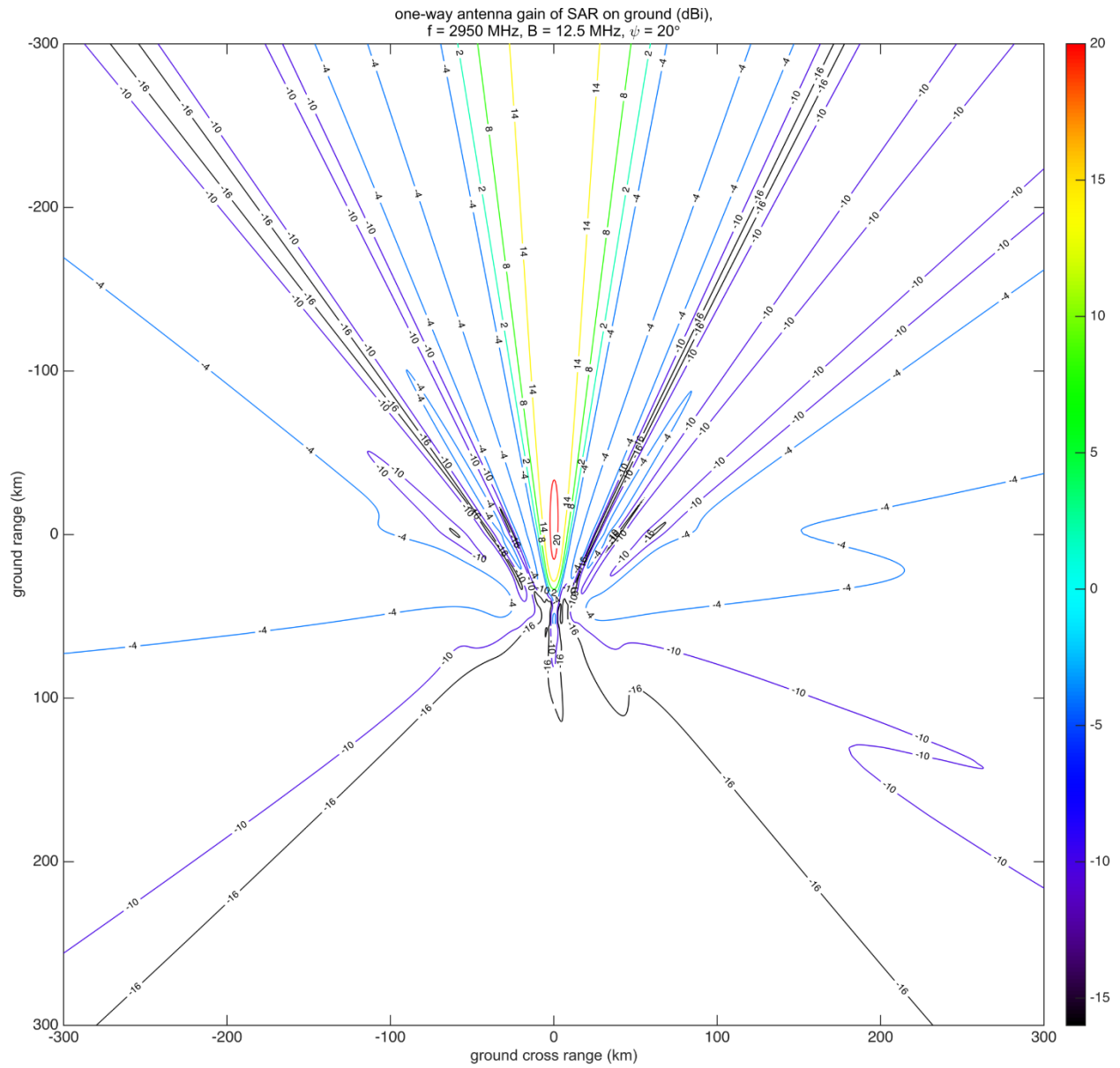

Figure 3. SRI Radar Antenna Beam Projected to Ground, 20 deg Grazing Angle

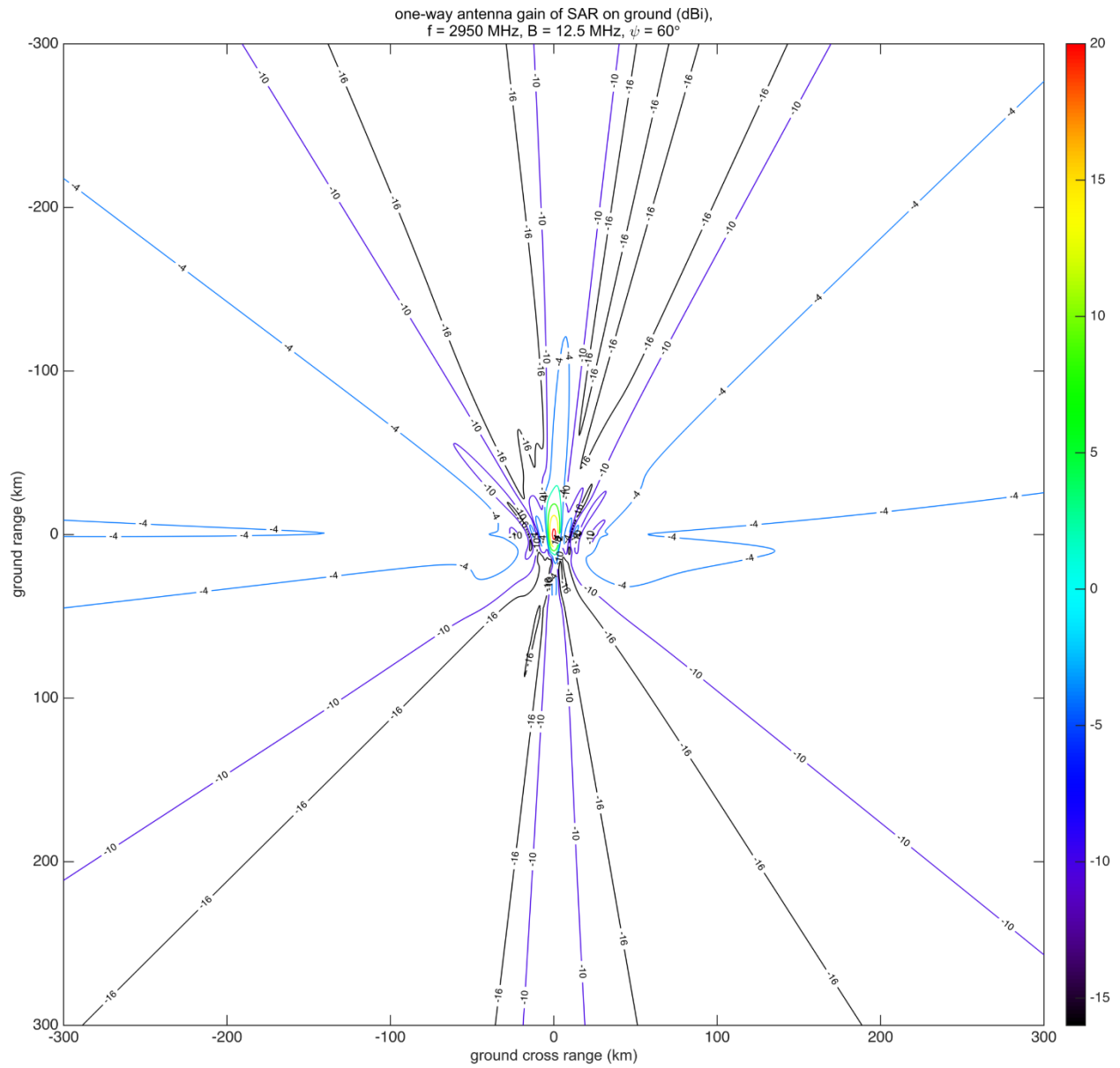

Figure 4. SRI Radar Antenna Beam Projected to Ground, 60 deg Grazing Angle

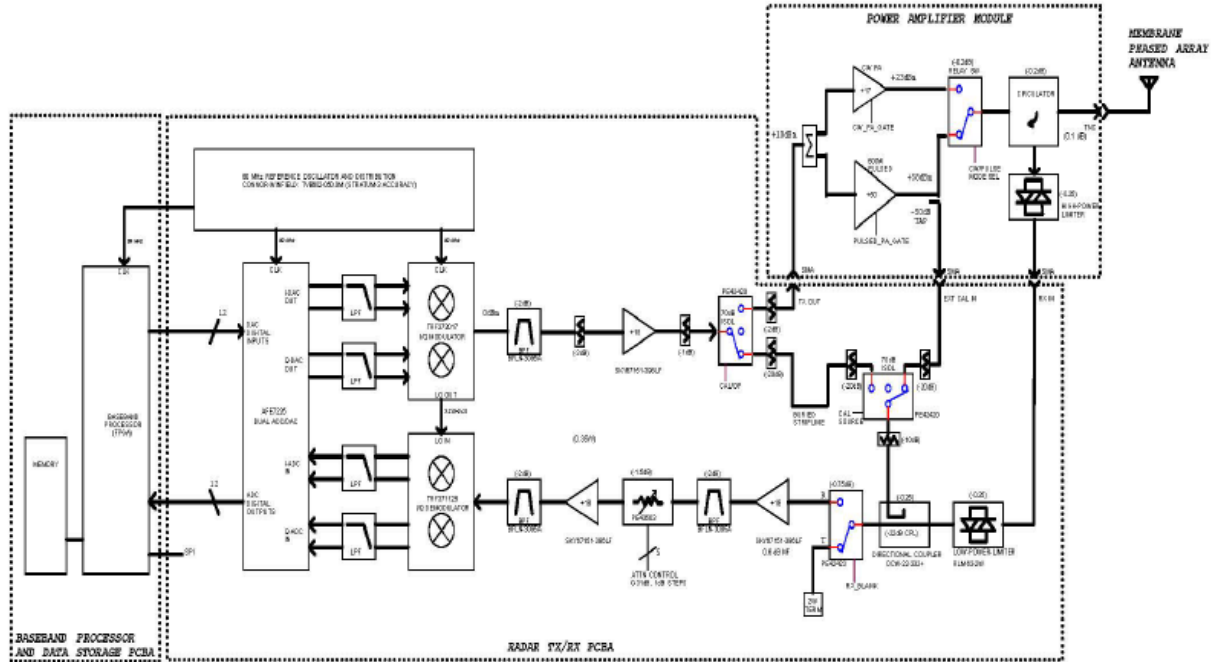

Figure 5. SRI International Experimental S-band Radar System

Table 1. Balloon Radar Transmitter Parameters

	Radar Transmitter
Frequency Range	2.96-3.00 GHz
Bandwidth	40 MHz
Emission Designation	40MM3N
Waveform Type	Pulsed linear FM chirp
Transmit Power, Avg	60 W
Transmit Antenna Gain	21 dBi
EIRP, Avg	7500 W
Transmitter Part Number	SRI custom
Antenna Part Number	SRI custom