

SRI International S-band High Altitude Balloon Radar Experiment

This document describes SRI International's high altitude balloon radar experiment and the need for Special Temporary Authority (STA) license through the FCC.

Experiment Overview

SRI is planning to test an experimental S-band radar system on a high altitude balloon. The balloon tests are expected to take place between approximately the second week of August to the second week of February. This window is allowing for multiple flights of the instrument for risk reduction testing, as well as flight reschedules due to problems with weather or equipment malfunctions. The radar system is designed to generate synthetic aperture radar (SAR) for the purpose of characterizing the ground backscatter for various Earth Science applications. The radar system is built by SRI International and consists of a custom transmitter, receiver unit, and antenna unit. In addition to the radar, the balloon payload will include a 900 MHz communication link that allows data and control command transfer between the airborne balloon and a nearby ground station. Also, on board is an Iridium and Inmarsat communication link that allows telemetry transfer between the airborne balloon and Iridium or Inmarsat satellites. Lastly, the payload includes a commercial C-band communication link manufactured by Cambium Networks for a higher data rate direct-to-ground downlink.

The balloons planned ascent will be near Baltic, SD, latitude/longitude of approximately 42N to 46N, 95W to 97W. While aloft, the balloon will fly at altitudes between 55,000 and 65,000 ft, with a target altitude of approximately 60,000 ft. The anticipated area of operation is between 40N to 48N latitude, and 88W to 104W longitude. The radar will operate periodically over the flight path, transmitting once about 3 minutes for every 10 minutes while aloft. The balloon-ground station links will be operated more regularly over the flight path to upload payload commands and downlink radar data and telemetry. Because the intent of the experiment is to image the ground, the radar antenna will always be pointed at an elevation angle below the horizon.

Balloon Payload Radar Description

The SRI radar consists of a custom S-band transmitter and receiver unit designed and built by SRI International. The radar transmits a pulsed linear FM chirp signal over **2.93625 to 3.35GHz**, having an instantaneous BW of **200 MHz** bandwidth. The transmitter outputs the waveform with an average power of about 60 W. A 21 dBi gain antenna is used with the transmitter, resulting in an EIRP of 7500 W average. The radar will operate with a maximum pulse repetition frequency (PRF) of 4000 Hz, a maximum pulse width of 100 microseconds, and a duty cycle of 10%. The radar antenna has a beamwidth of 10 deg in the azimuth (horizontal) plane and 27 deg in the elevation plane. The directive antenna will be pointed at a depression angle between 10 and 70 deg below the horizon. Figure 5 shows a schematic of the SRI S-band radar system. Prior to launching the balloon, the radar will be tested on the ground in Baltic, SD to check EMI emissions.

The radar transmitter has the following emission mask, which was measured in the laboratory with a spectrum analyzer at 1 MHz resolution bandwidth

- -3 dB bandwidth: 200 MHz

- -20 dB bandwidth: 215 MHz
- -40 dB bandwidth: 228 MHz
- -50 dB Bandwidth: 240 MHz

Spurious and harmonic emission measurements were also made of the radar transmitter outputs:

- Spurious emissions over 2.93625 to 3.13625 GHz: -50 dBc
- Spurious emissions out of band: -50 dBc
- Harmonics: -50 dBc

The radar center frequency is tunable up to 3.25 GHz; the emission mask and spurious/harmonic measurements translate with the center frequency.

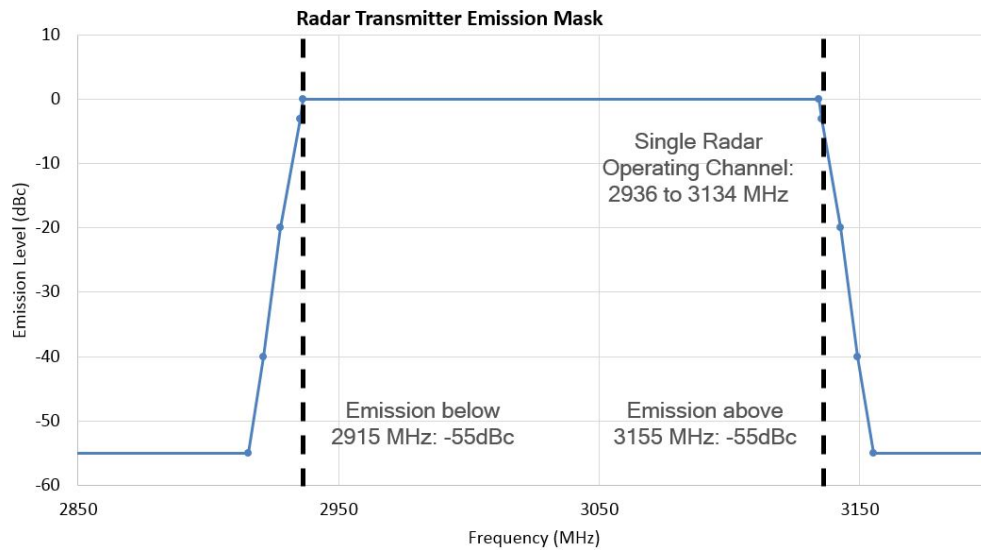

Figure 1. Radar Transmitter Emission Mask

UHF Ground-Balloon Communication Link Description

While the balloon is airborne, SRI will maintain communication with the balloon radar payload via a 900 MHz ISM-band communication link. Both the ground station and the balloon will utilize a Digi XLR Pro commercial transceiver that operates over 910 to 920 MHz. The transceiver utilizes a chirp spread-spectrum waveform to minimize interference with other transceivers. For the ground station, the transceiver unit will output an average power of 1 W and be connected to a 13.5 dBi gain antenna for an average EIRP of 22 W. For the balloon side of the link, the transceiver unit will output an average power of 1 W and be connected to a 3 dBi gain antenna for an average EIRP of 2 W. While the balloon is aloft SRI will operate a mobile ground station that will follow the balloon flight path on the ground and maintain periodic communication with the balloon payload. SRI will utilize a maximum of two mobile ground stations along the balloon flight path at a time.

L Band Satellite-Balloon Communication Link Description

The Iridium link is a commercial off the shelf satellite communications solution. The Iridium link uses Time-Division Multiple Access (TDMA) and Frequency-Division Multiple Access (FDMA) transmission

schemes, with a Differentially Encoded Quadrature Phase Shift Keyed (DEQPSK) modulation scheme. The Iridium satellite constellation operates from 1616MHz to 1626.5MHz. The balloon will have two of these Iridium links. Each of these links average RF power is ~7W, and a standard 3dBi “Hockey Puck” antenna is connected, giving a EIRP of ~14W. The beamwidth is ~145 degrees.

C Band Ground-Balloon Communication Link Description

The C Band link is a commercial off the shelf satellite communications solution, purchased from Cambium Networks. The Cambium Networks link uses Time-Division Duplex (TDD) transmission scheme, with a fast preemptive adaptive modulation scheme, featuring 13 modulation/FEC coding levels ranging from BPSK to 256 QAM dual payload MIMO. The Cambium Networks link operates from 4.9GHz to 6.05GHz, with allowable frequencies and bands dependent on country of operation regulations. The link will be restricted to operation between 5.1 and 5.7GHz to avoid potential interference with DSRC systems supporting public safety in the 5850 - 5925 MHz band and to avoid potential interference with Radio Astronomy in the 4.990 - 5.000 GHz band. The system picks the least-occupied channels available, but can be configured to disable a list of specific channels. The balloon will have one Cambium Networks PTP670 Transmitter, and the mobile ground station has one as well. Each of these transmitters peak RF power is ~0.5W. These transmitters are certified to comply with FCC 47 CFR Part 90 (Outside the UNII band) and Part 15e (inside the UNII band), FCC Identifier QWP-50670. The balloon has a MARS 23dBi dual polarization panel antenna, part number: MA-WA56-DP23B, giving an EIRP of ~100W, this antenna has a 3dB beamwidth of ~10 degrees in both V and H planes. The ground station has a MARS 26dBi dual polarization antenna, part number: Mars MA-WA55-27-B, giving an EIRP of ~200 W, this antenna has a 3dB beamwidth of ~7.5degrees in both V and H planes.

Balloon Flight Path

The balloon will launch from Baltic, SD, it will ascend to its nominal operating altitude of 60,000 ft. SRI is requesting the STA license to operate the radar and comm link at any location within the anticipated area of operation between 40N to 48N latitude, and 88W to 104W longitude at balloon altitudes up to 60,000 ft. SRI also plans to operate the balloon radar and comm link while the balloon ascends from Baltic, SD at altitudes between 5,000 and 60,000 ft. The ascending area of operation is between 42N and 46N latitude, 95W and 97W longitude. During the experiment, SRI operators will be able to disable the radar and/or radio transmitter at any time. Transmission of the radar and/or radio can be stopped by contacting either of the following SRI personnel:

- Lauren Wye: 650-678-9184
- Simon Lee: 805-801-9223

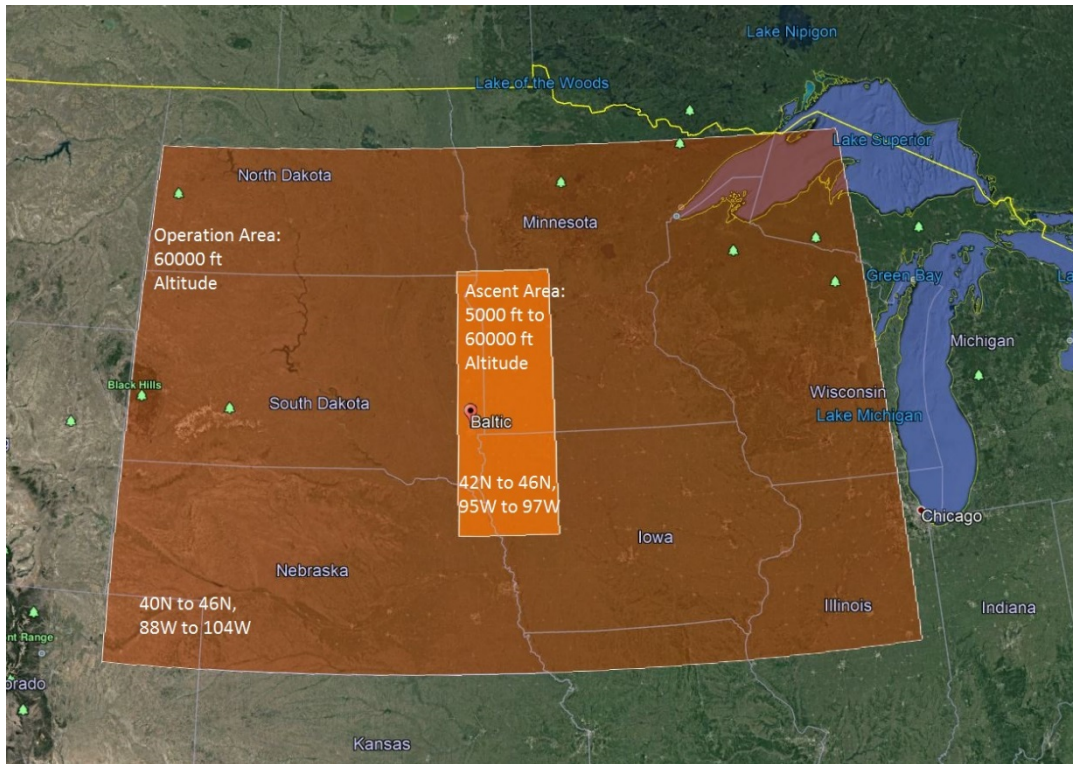

Figure 2. Balloon launch site in Baltic, SD, expected flight path, and area of operation at altitudes between 5,000 and 60,000 ft over 42N to 46N, 95W to 97W, and at 60,000 ft altitude over 40N to 48N, 88W to 104W.

During the balloon experiment, SRI will refrain from pointing the heading direction of the antenna toward the FAA station at Dodge City, KS. As seen in Figures 3 and 4 below, the radar antenna has a narrow beam in the azimuth direction. To mitigate interference with the FAA station, SRI will avoid pointing the antenna toward Dodge City, KS by at least 20 deg azimuth, which will put the line of sight towards the FAA station out of the SRI radar antenna main beam. This will reduce the antenna gain for the radar antenna by at least 25 dB from peak in the direction toward the FAA station. SRI will also have operators standing by that can disable the radar transmitter at a moment's notice.

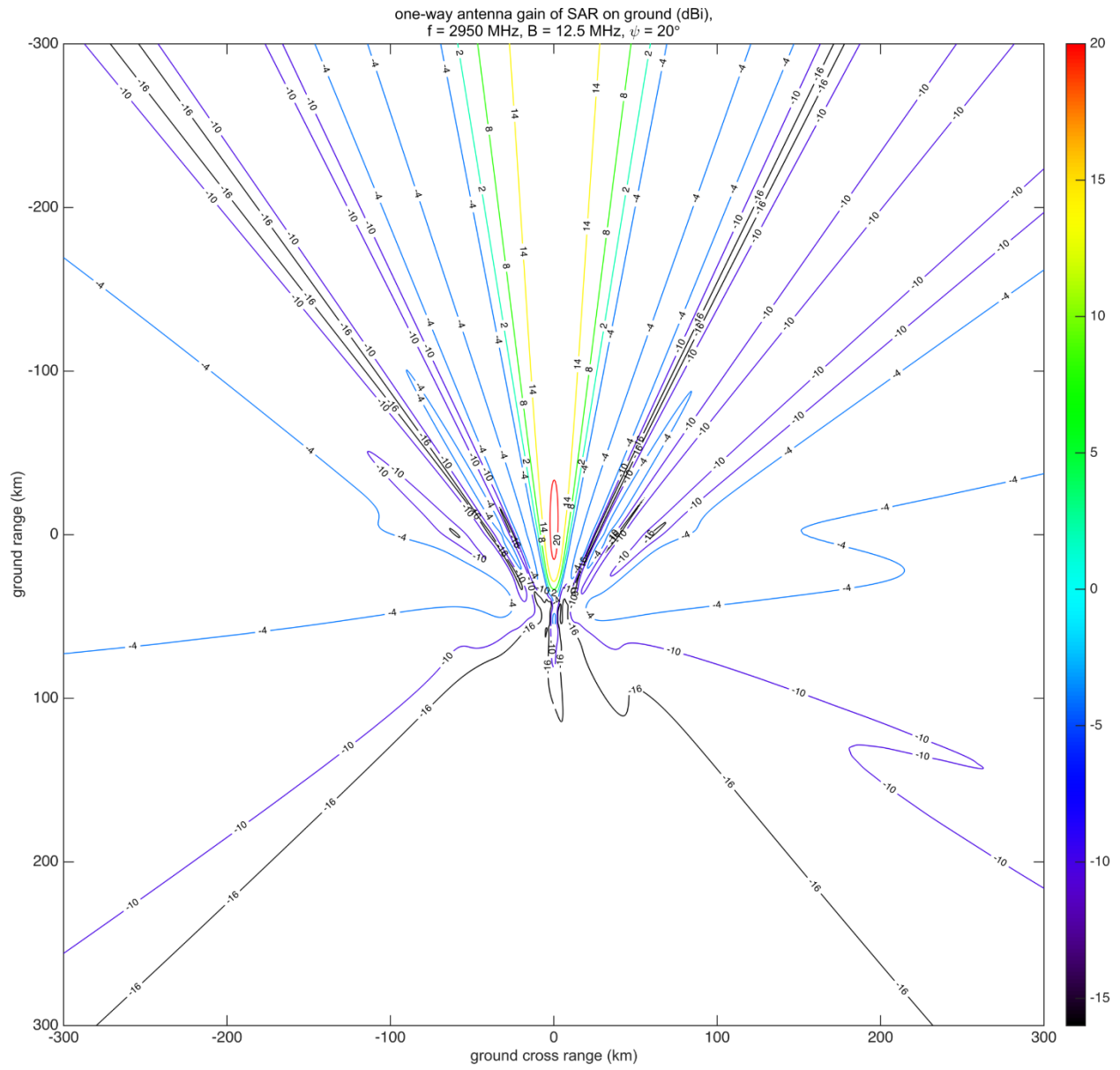

Figure 3. SRI Radar Antenna Beam Projected to Ground, 20 deg Grazing Angle

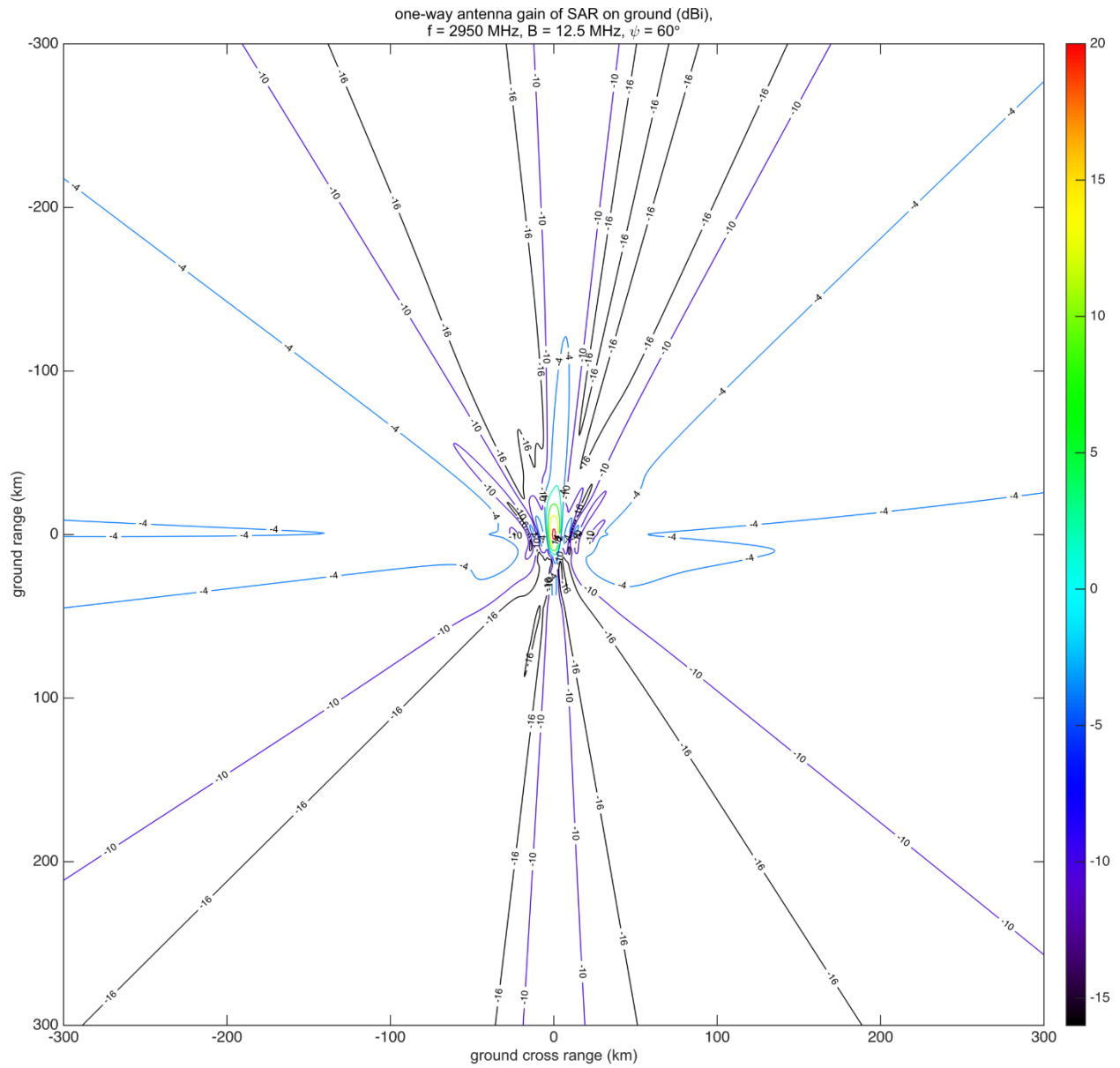

Figure 4. SRI Radar Antenna Beam Projected to Ground, 60 deg Grazing Angle

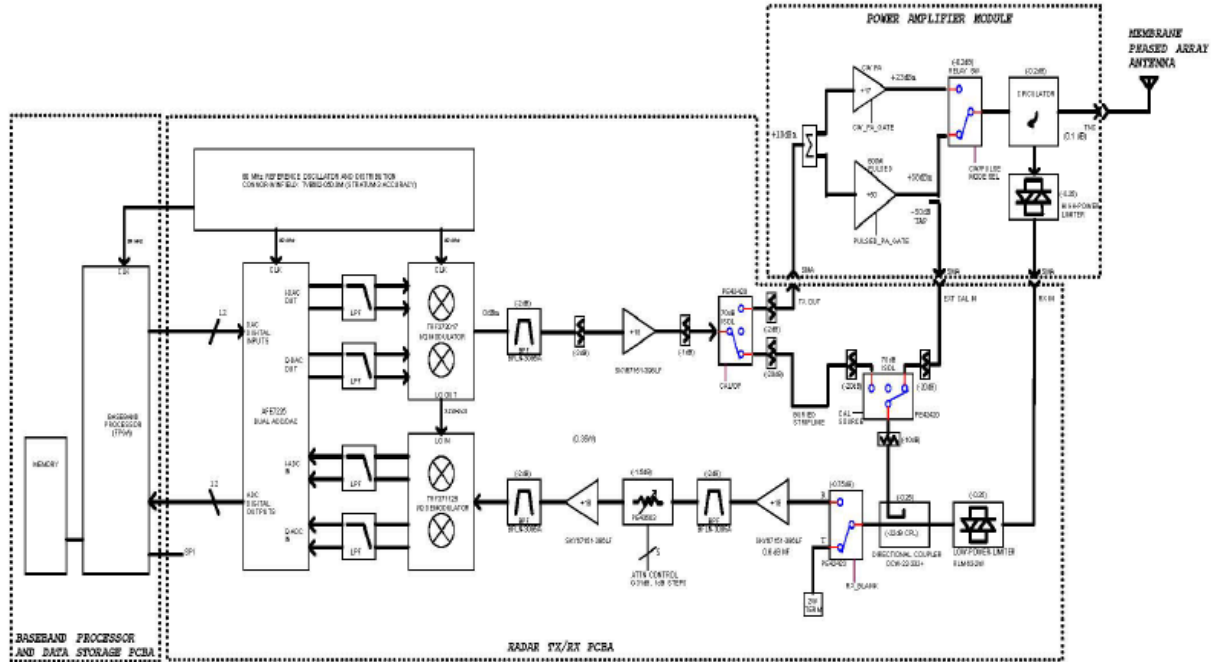

Figure 5. SRI International Experimental S-band Radar System

Table 1. Balloon Radar and Comm Link Transmitter Parameters

	Balloon Radar Transmitter	UHF Balloon Comm Link Transmitter	UHF Ground Station Comm Link Transmitter	C-Band Balloon Comm Link Transmitter	C-Band Ground Station Comm Link Transmitter	Balloon Satellite Link Transmitter
Frequency Range	2.93625 to 3.35 GHz	910 to 920 MHz	910 to 920 MHz	4.9 to 6.05 GHz (Restricted to 5.1 to 5.7GHz)	4.9 to 6.05 GHz (Restricted to 5.1 to 5.7GHz)	1616 to 1626.5 MHz
Bandwidth	200.0 MHz	10 MHz	10 MHz	5, 10, 15, 20, 25, 30, 35, 40, 45 MHz	5, 10, 15, 20, 25, 30, 35, 40, 45 MHz	10.5MHz
Emission Designation	200MM3N	10M0F3D	10M0F3D	5M00D2D 45M0D2D	5M00D2D 45M0D2D	10M5M7D
Waveform Type	Pulsed linear FM chirp	Chirp Spread Spectrum	Chirp Spread Spectrum	OFDM-BPSK, OFDM-QPSK, OFDM-QAM	OFDM-BPSK, OFDM-QPSK, OFDM-QAM	Differentially Encoded QPSK
Transmit Power, Avg	60 W	1 W	1 W	0.5 W (Max)	0.5 W (Max)	7 W
Transmit Antenna Gain	21 dBi	3 dBi	13.5 dBi	23 dBi	26 dBi	3 dBi
EIRP, Avg	7500 W	2 W	22 W	100 W	200 W	14 W
Transmitter Part Number	SRI custom	Digi XLR Pro	Digi XLR Pro	Cambium Networks PTP670	Cambium Networks PTP670	9522B DataMODEM RST600B and RockBlock MK2
Antenna Part Number	SRI custom	L-Com HG903RD-SM	KP Performance KPPA-900DP-FP	MA-WA56-DP23B	Mars MA-WA55-27-B	Iridium Aero Antenna