

SRI International S-band High Altitude Balloon Radar Experiment

This document describes SRI International's high altitude balloon radar experiment and the need for Special Temporary Authority (STA) license through the FCC.

Experiment Overview

SRI is planning to test an experimental S-band radar system on a high altitude balloon. The balloon test will occur over a single 3-day period between **April 10th and April 13th**. The radar system is designed to generate synthetic aperture radar (SAR) and interferometric synthetic aperture radar imagery for the purpose of measuring land deformation. The radar system is built by SRI International and consists of a custom transmitter, receiver unit, and antenna unit. In addition to the radar, the balloon payload will include a 900 MHz communication link that allows data and control command transfer between the airborne balloon and a nearby ground station, as well as an Iridium communication link that allows telemetry transfer between the airborne balloon and Iridium satellites.

The planned balloon flight path extends from Bakersfield, CA to China Lake, CA. While aloft, the balloon will fly at altitudes between 50,000 and 68,000 ft, with a target altitude of approximately 60,000 ft. The anticipated area of operation is approximately between 34N to 37N latitude, and 117W to 119W longitude. The radar will operate sporadically over the flight path, transmitting for only a maximum of 10 minutes every hour while aloft, while the balloon-ground station link will be operated more regularly over the flight path to upload payload commands and downlink radar data and telemetry. Because the intent of the experiment is to image the ground, the radar antenna will always be pointed at an elevation angle below the horizon.

Balloon Payload Radar Description

The SRI radar consists of a custom S-band transmitter and receiver unit designed and built by SRI International. The radar transmits a pulsed linear FM chirp signal over **2.93625 to 2.97625 GHz**. The waveform has a **40 MHz** bandwidth. The transmitter outputs the waveform with an average power less than 60 W. A 21 dBi gain antenna is used with the transmitter, resulting in an EIRP of 7500 W average. The radar will operate with a nominal pulse repetition frequency (PRF) of 2500 Hz, a pulse width of 40 microseconds, and a duty cycle of 10%. The radar antenna has a beamwidth of 10 deg in the azimuth (horizontal) plane and 27 deg in the elevation plane. The directive antenna will be pointed at a depression angle between 20 and 60 deg below the horizon. Figure 3 shows a schematic of the SRI S-band radar system. Prior to launching the balloon, the radar will be tested on the ground in Bakersfield, CA to check EMI emissions.

The radar transmitter has the following emission mask, which was measured in the laboratory with a spectrum analyzer at 330 kHz resolution bandwidth

- -3 dB bandwidth: 42 MHz
- -20 dB bandwidth: 50 MHz
- -40 dB bandwidth: 60 MHz
- -60 dB bandwidth: 70 MHz

Spurious and harmonic emission measurements were also made of the radar transmitter outputs:

- Spurious emissions over 2.90 to 3.00 GHz: -40 dBc
- Spurious emissions out of band: -60 dBc
- Harmonics: -40 dBc

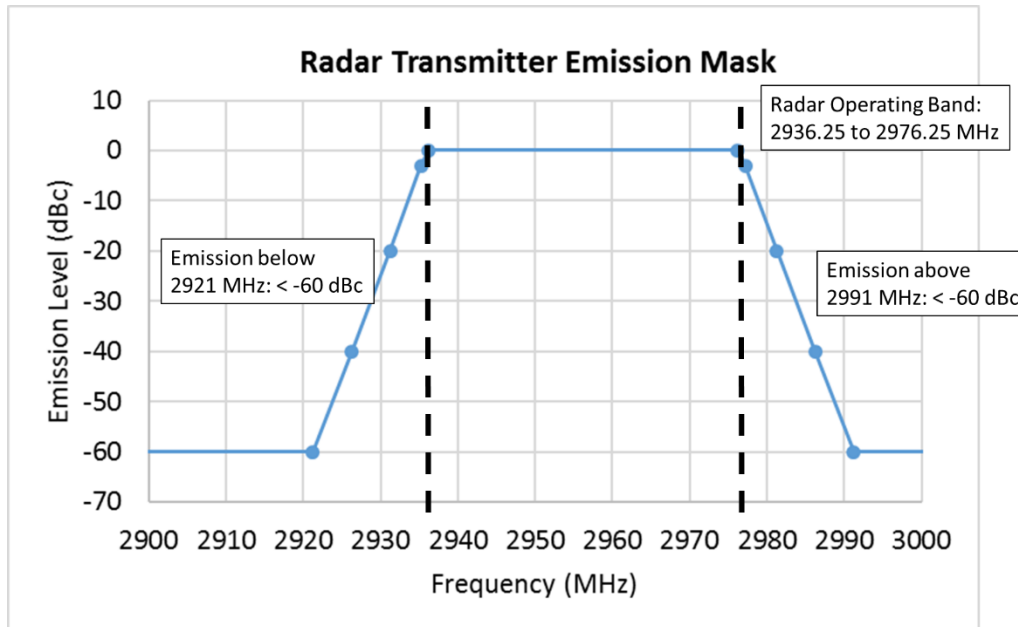

Figure 1. Radar Transmitter Emission Mask

Ground-Balloon Communication Link Description

While the balloon is airborne, SRI will maintain communication with the balloon radar payload via a 900 MHz ISM-band communication link. Both the ground station and the balloon will utilize a Digi XLR Pro commercial transceiver that operates over 910 to 920 MHz. The transceiver utilizes a chirp spread-spectrum waveform to minimize interference with other transceivers. For the ground station, the transceiver unit will output an average power of 1 W and be connected to a 13.5 dBi gain antenna for an average EIRP of 22 W. For the balloon side of the link, the transceiver unit will output an average power of 1 W and be connected to a 3 dBi gain antenna for an average EIRP of 2 W. While the balloon is aloft SRI will operate a mobile ground station that will follow the balloon flight path on the ground and maintain periodic communication with the balloon payload. SRI will utilize a maximum of two mobile ground stations along the balloon flight path at a time.

Balloon Flight Path

The balloon will launch from Bakersfield, CA and fly toward China Lake, CA. SRI is requesting the STA license to operate the radar and comm link at any location within the anticipated area of approximately between 34N to 37N latitude, and 117W to 119W longitude at balloon altitudes up to 60,000 ft. SRI also plans to operate the balloon radar and comm link while the balloon ascends from Bakersfield, CA at altitudes between 5,000 and 60,000 ft. The ascending area of operation is between 34N and 36N latitude, 117W and 119W longitude. SRI is working with Naval Air Weapons Station China Lake for spectrum authority over China Lake. During the experiment, SRI operators will be able to disable the

radar and/or radio transmitter at any time. Transmission of the radar and/or radio can be stopped by contacting either of the following SRI personnel:

- Lauren Wye: 650-678-9184
- Simon Lee: 805-801-9223

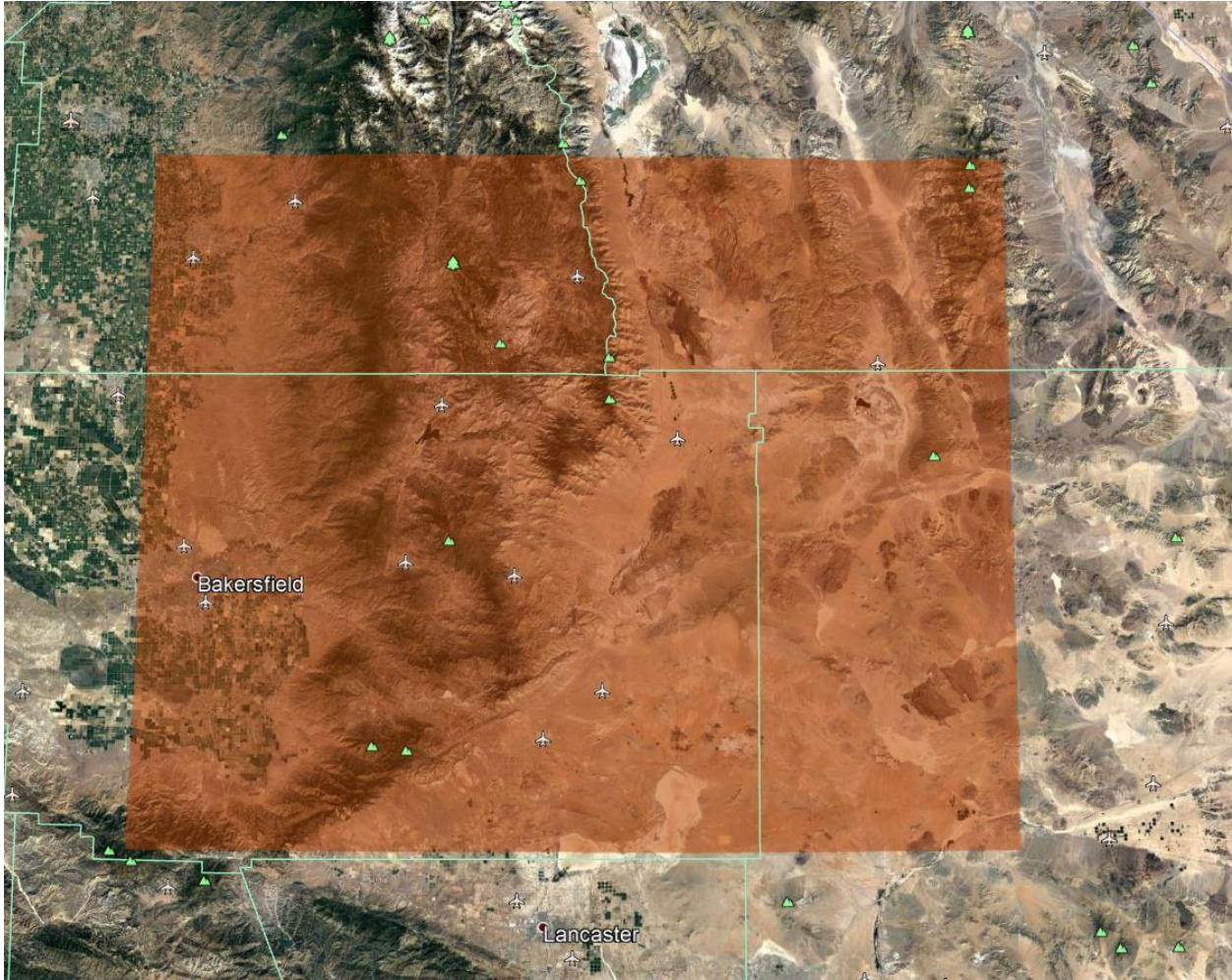

Figure 2. Balloon launch site in Bakersfield, CA, expected flight path, and area of operation at altitudes between 5,000 and 60,000 ft over approximately 34N to 37N, 117W to 119W.

During the balloon experiment, SRI will refrain from pointing the heading direction of the antenna toward the FAA station at Dodge City, KS. As seen in Figures 3 and 4 below, the radar antenna has a narrow beam in the azimuth direction. To mitigate interference with the FAA station, SRI will avoid from pointing the antenna toward Dodge City, KS by at least 20 deg azimuth, which will put the line of sight towards the FAA station out of the SRI radar antenna main beam. This will reduce the antenna gain for the radar antenna by at least 25 dB from peak in the direction toward the FAA station. SRI will also have operators standing by that can disable the radar transmitter at a moment's notice.

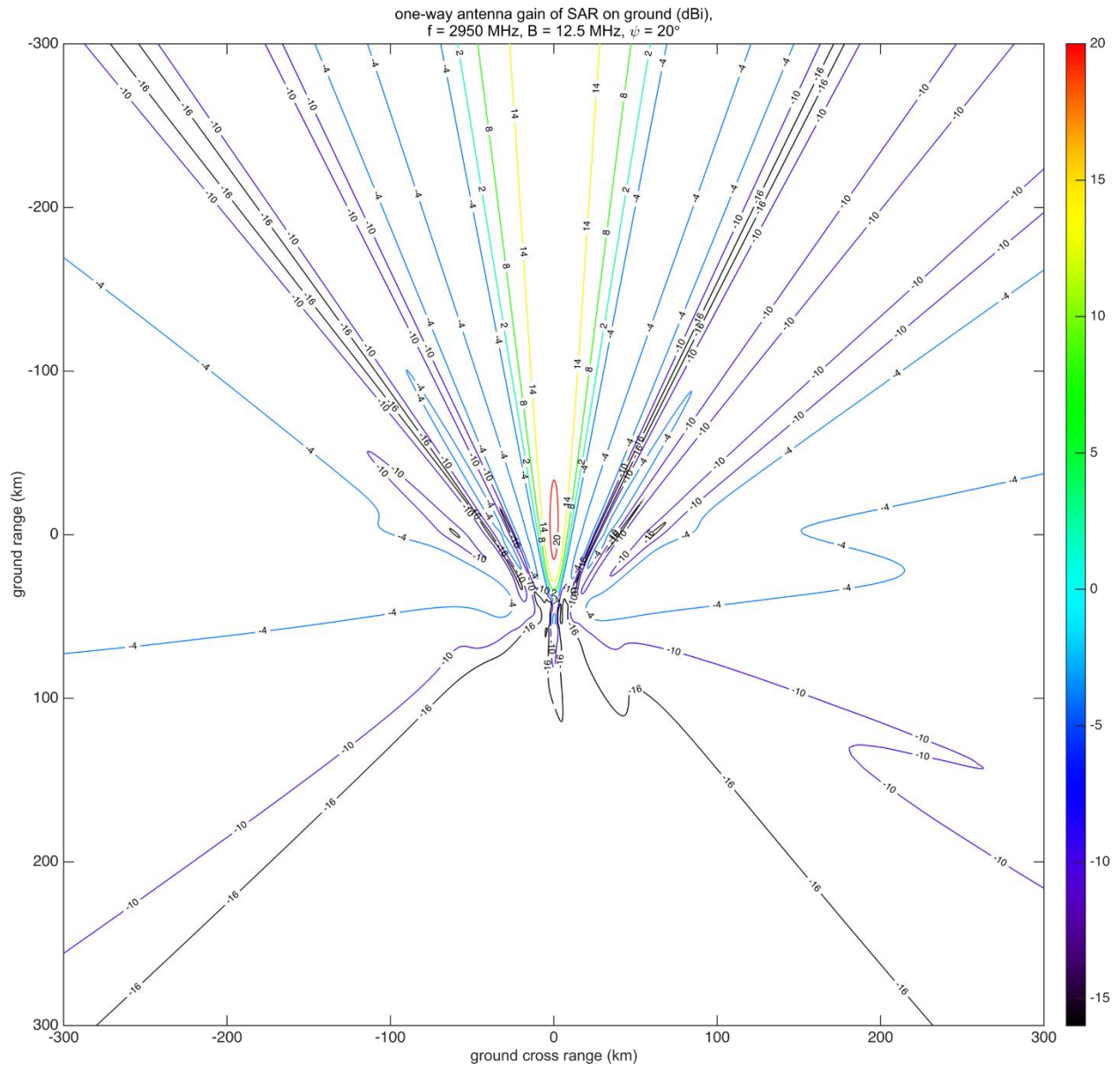

Figure 3. SRI Radar Antenna Beam Projected to Ground, 20 deg Grazing Angle

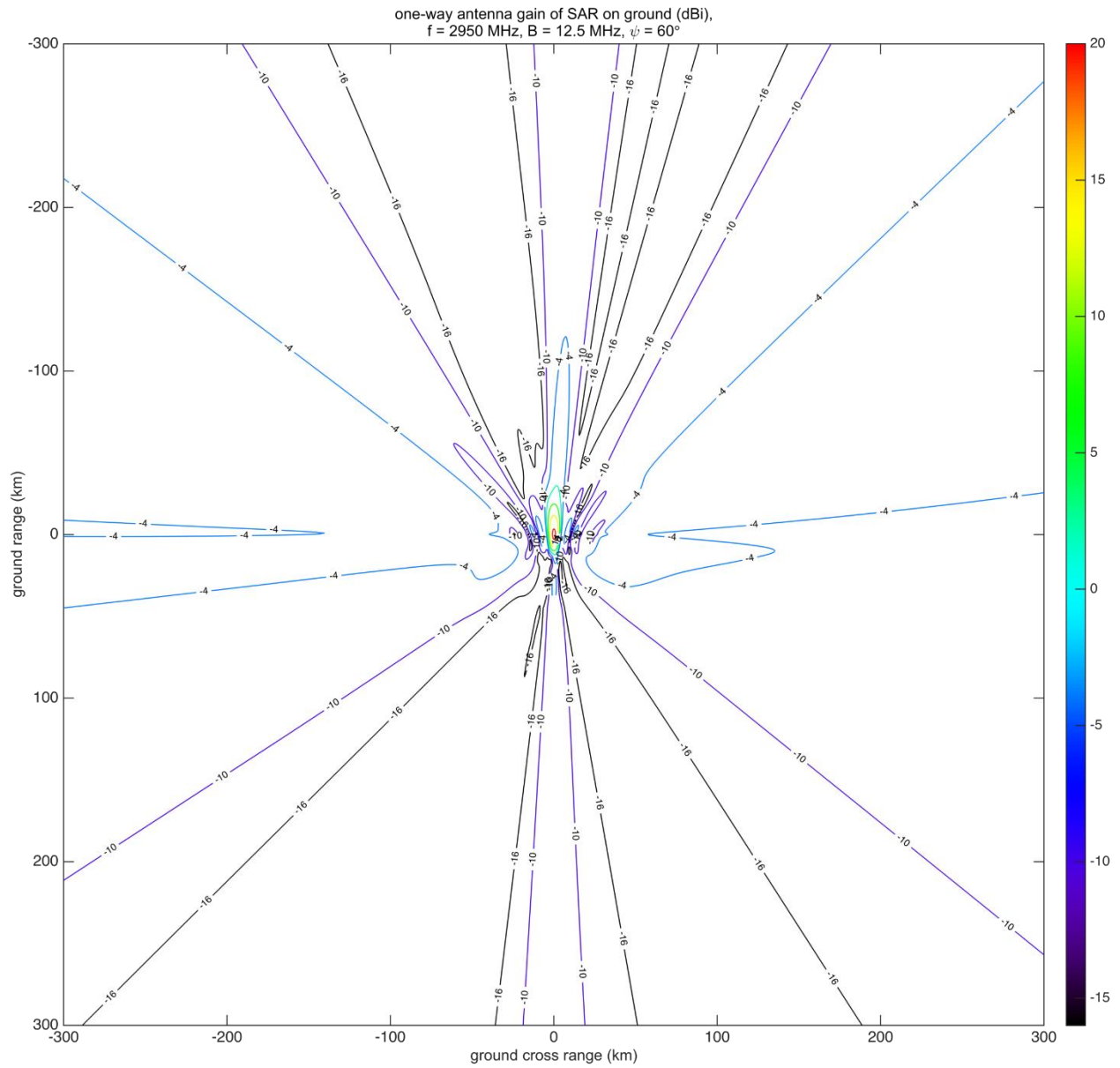

Figure 4. SRI Radar Antenna Beam Projected to Ground, 60 deg Grazing Angle

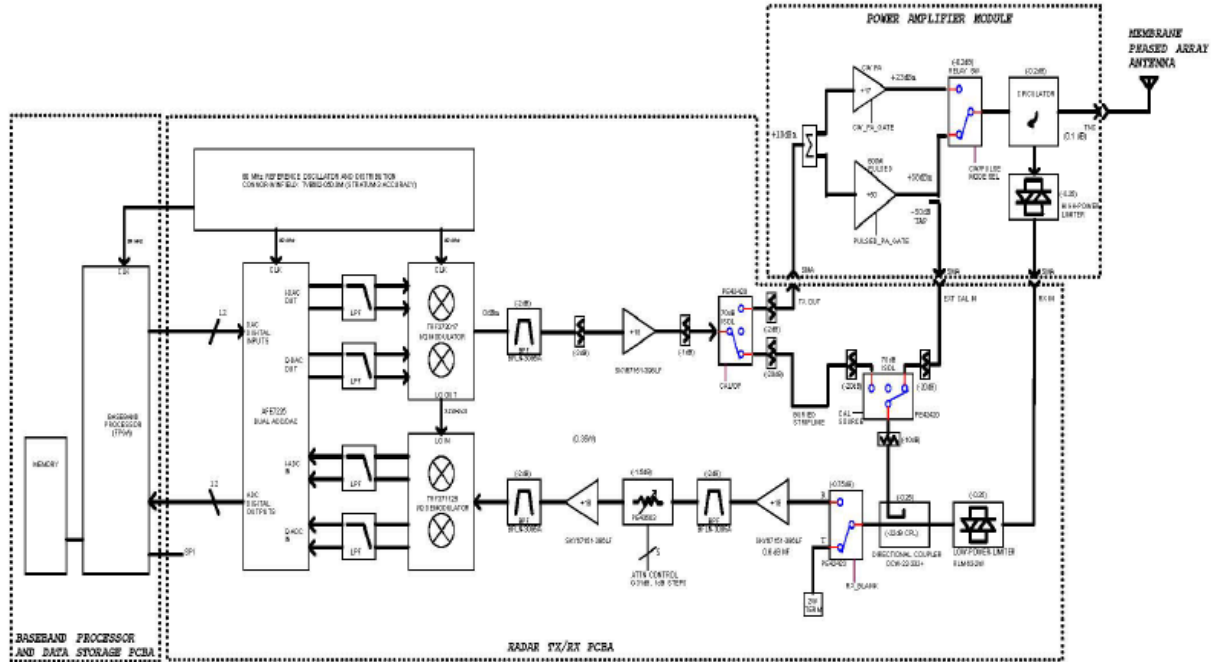

Figure 5. SRI International Experimental S-band Radar System

Table 1. Balloon Radar and Comm Link Transmitter Parameters

	Balloon Radar Transmitter	Balloon Comm Link Transmitter	Ground Station Comm Link Transmitter
Frequency Range	2.93625 to 2.97625 GHz	910 to 920 MHz	910 to 920 MHz
Bandwidth	40.0 MHz	10 MHz	10 MHz
Emission Designation	40M5M3N	10M0F3D	10M0F3D
Waveform Type	Pulsed linear FM chirp	Chirp Spread Spectrum	Chirp Spread Spectrum
Transmit Power, Avg	60 W	1 W	1 W
Transmit Antenna Gain	21 dBi	3 dBi	13.5 dBi
EIRP, Avg	7500 W	2 W	22 W
Transmitter Part Number	SRI custom	Digi XLR Pro	Digi XLR Pro
Antenna Part Number	SRI custom	L-Com HG903RD-SM	KP Performance KPPA-900DP-FP