

SRI International S-band Airborne Radar Experiment

This document describes SRI International's S-band airborne radar experiment which is the subject of the FCC Experimental License application.

Experiment Description

SRI is planning to test an experimental S-band radar system starting in September 2017. The radar system is designed to generate synthetic aperture radar (SAR) and interferometric synthetic aperture radar (InSAR) imagery for the purpose of measuring land deformation. The radar system is built by SRI International and consists of a custom transmitter and receiver unit and utilizes an antenna with up to 21 dB gain. The radar system will be tested at SRI's facilities in Ann Arbor, Michigan and Menlo Park, California. Radar testing may include short-term outdoor operation at these SRI facilities. The radar will also be operated on an aircraft flown in areas around Muskegon Michigan, Crow's Landing California, Tracy California, Baltic South Dakota, and Elko Nevada.

Ground-based outdoor and airborne testing of the radar system will begin in September 2017 and continue during 2018. Radiative testing of the system will be infrequent: less than one week of outdoor and flight testing per month at 4 hr intervals or less.

Radar Description

As discussed above, the radar consists of a custom S-band transmitter and receiver unit designed and built by SRI International. The radar transmits a linear FM chirp signal over 2.9 to 2.95 GHz. The waveform has a 50 MHz bandwidth. The transmitter outputs the waveform with an average power of 60 W. A 21 dBi gain antenna is used with the transmitter, resulting in an EIRP of 7500 W average.

During ground-based outdoor testing, the antenna will be placed on the roof of an approved facility or other raised platform and pointed down to the ground. The antenna could be oriented in any azimuth direction during testing. During airborne testing, the antenna will be mounted to the aircraft in a fixed orientation. As the aircraft flies, the antenna's azimuth pointing direction will change with respect to the aircraft flight pattern, thus the antenna could be pointed in any azimuth direction.

Figure 1 below shows a schematic of the SRI S-band radar system.

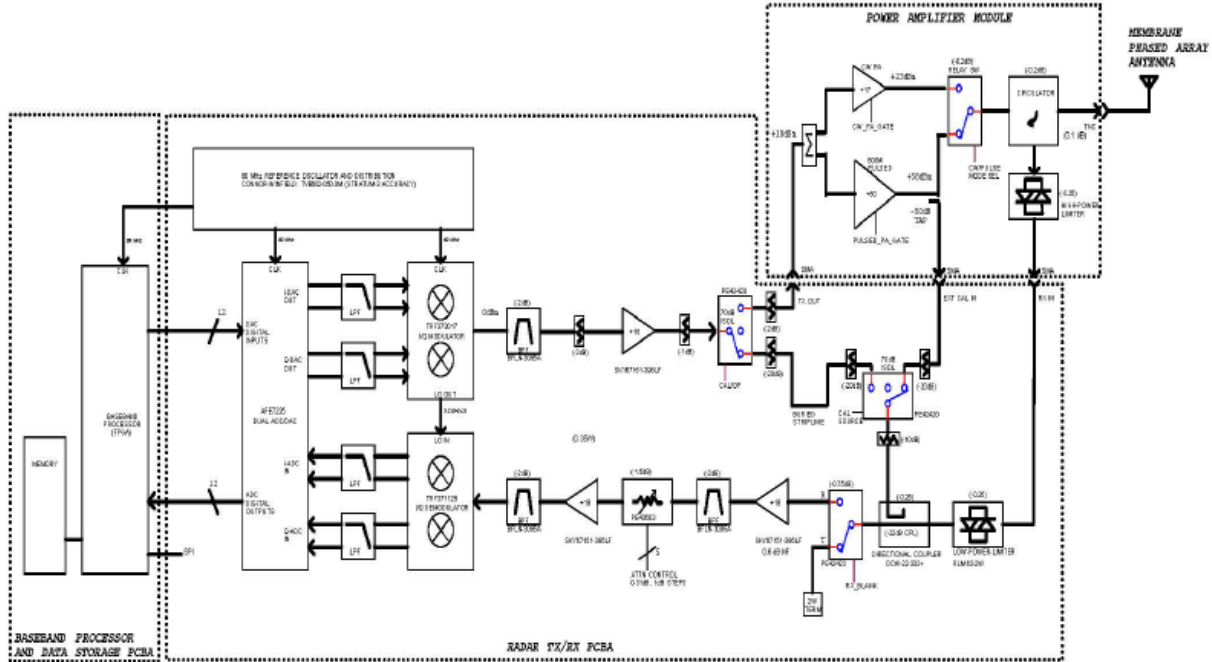

Figure 1. SRI International Experimental S-band Radar System

Key Details from FCC Temporary Experimental License Application

- FCC file number: 0400-EX-CN-2017
- Frequency band: 2.9 to 2.95 GHz
- Bandwidth: 50 MHz
- Emission designation: 50M0M3N
- Waveform type: linear FM chirp
- Antenna beamwidth: 31 deg
- Avg transmit power: 60 W
- Avg transmit EIRP: 7500 W
- Locations of operation: Ann Arbor, MI; Muskegon, MI; Menlo Park, CA; Crows Landing, CA; Tracy, CA; Baltic, SD; Elko, NV
- Radius of operation at each location: 100 km