

SDR-KIT 980B Module

SDR-KIT 980B offers the ability to integrate 9.8GHz X-band software-defined transmitter-receiver systems with the processor module SDR-PM 402 for various applications.

The SDR Evaluation Kit includes:

- One SDR-RF 980B module
- One SDR-PM 402 processor module
- One copy of SDR-GUI graphical user interface software
- One AC/DC power adapter (5V, 3.0A)
- One mini USB retractable cable
- One pair of RF cables
- One pair of the transmitting and receiving antennas

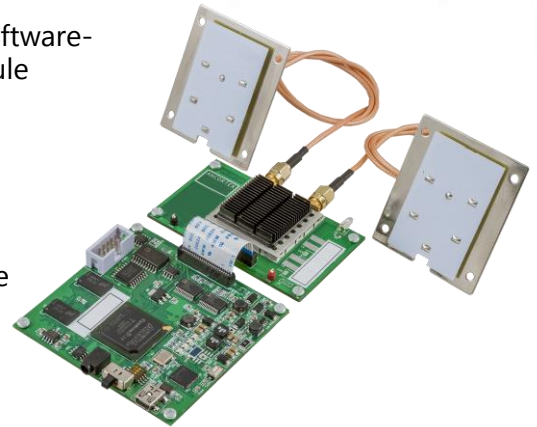

The SDR processor module SDR-PM 402 is compatible with this SDR-RF 980B module. The graphic user interface software SDR-GUI is for activating this RF module, selecting operation parameters, and collecting data.

The graphical user interface SDR-GUI is used to control the configuration of the SDR Evaluation Kit via a USB 2.0 cable. Digital samples of control voltage are generated by the FPGA firmware, and then converted to analog control voltage which directly feeds the voltage controlled oscillator (VCO). The output of the mixer in the receive chain is digitized and streamed to host computer for real-time processing.

FEATURES

- FMCW/FSK/CW waveforms
- Reconfigurable
- Wide bandwidth up to 400MHz (9.6GHz-10.0GHz)
- Output power > 17dBm
- Low phase noise
- Low noise figure over receiver channel
- Low power consumption
- Suppression of cooling fan interference
- On board automatic correction of VCO nonlinearity
- Compactness and flexibility

SDR-KIT 980B Block Diagram

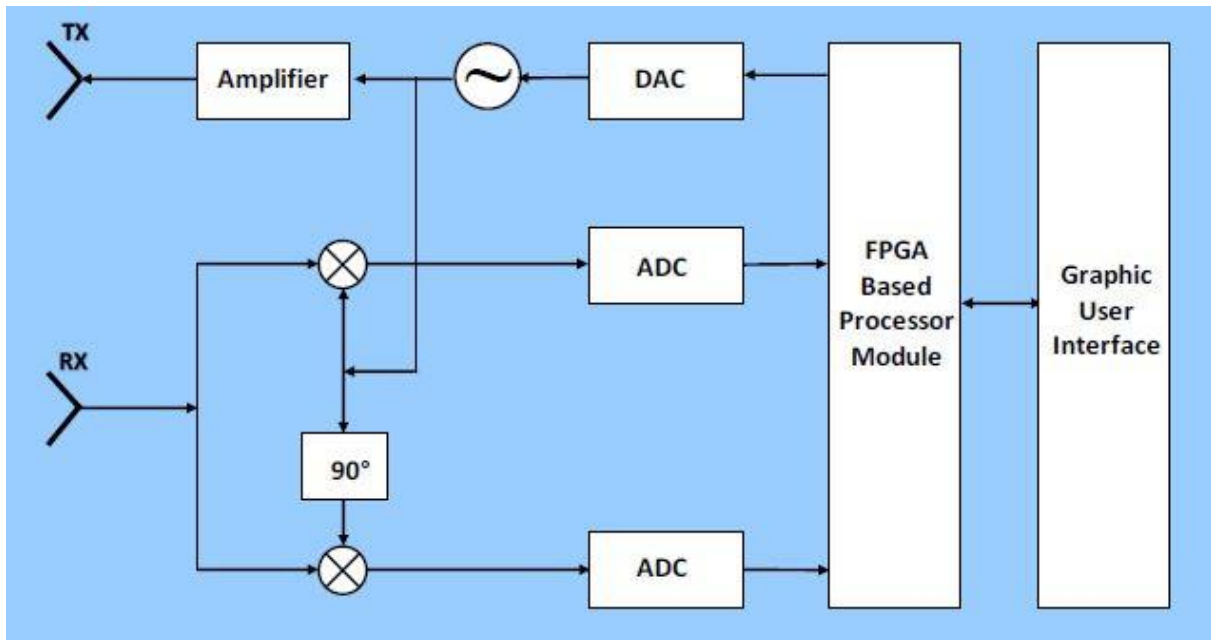

SDR-RF 980B Module Specifications

Parameter	Units	Value
Waveform		CW/FMCW/FSK
Center Frequency	GHz	9.8
FM Swept Bandwidth*	MHz	100, 150, 300, 400
FSK Frequency Step	MHz	6
Sweep Time	ms	1, 2, 4, 6
Number of Samples per Sweep		128, 256, 512, 1024
Power Output	dBm	18
Antenna Gain	dBi	12

SDR-KIT 980B Sample Applications

- Anti-collision
- Motion detection
- Environmental monitoring
- 3-D level meter
- High resolution SAR and ISAR imaging

To Purchase:

Ancortek Inc.

11092 B Lee Highway
Suite 104
Fairfax, VA 22030

+1-703-531-8997

info@ancortek.com

www.ancortek.com

We offer customization!

Please contact us
regarding your custom
development needs.