

# Orbital Debris Assessment Report

## ThinSat-1

per NASA-STD 8719.14A

## Signature Page

Hank Voss / HV 7/20/18

Hank Voss, NSL President and Chief Scientist,  
NearSpace Launch, Inc.

Matt Orvis / MO 7/20/18

Matt Orvis, Project Manager,  
NearSpace Launch, Inc.

Matt Craft / MC 7-20-18

Matt Craft, VP and Managing Member,  
Twiggs Space Lab, LLC

Mike Miller / MM July 20, 2018

Mike Miller, Licensing Coordinator,  
Sterk Solutions Corporation

## REFERENCES:

- A. *NASA Procedural Requirements for Limiting Orbital Debris Generation*, NPR 8715.6A, 5 February 2008
- B. *Process for Limiting Orbital Debris*, NAS A-STD-8719.14A, 25 May 2012
- C. International Space Station Reference Trajectory, delivered May 2017
- D. McKissock, Barbara, Patricia Loyselle, and Elisa Vogel. *Guidelines on Lithium-ion Battery Use in Space Applications*. Tech. no. RP-08-75. NASA Glenn Research Center Cleveland, Ohio
- E. *UL Standard for Safety for Lithium Batteries, UL 1642*. 1JL Standard. 4th ed. Northbrook, IL, Underwriters Laboratories, 2007
- F. Kwas, Robert. Thermal Analysis of ELaNa-4 CubeSat Batteries, ELVL-2012-0043254; Nov 2012
- G. Range Safety User Requirements Manual Volume 3- Launch Vehicles, Payloads, and Ground Support Systems Requirements, AFSCM91-710 V3.
- H. HQ OSMA Policy Memo/Email to 8719.14: CubeSat Battery Non-Passivation, Suzanne Aleman to Justin Treptow, 10, March 2014
- I. HQ OSMA Email: 6U CubeSat Battery Non Passivation Suzanne Aleman to Justin Treptow, 8 August 2017

This report is intended to satisfy the orbital debris requirements listed in *NASA Procedural Requirements for Limiting Orbital Debris Generation*, NPR 8715.6A, 5 February 2008, for the ThinSat-1 mission.

Sections 1 through 8 of *Process for Limiting Orbital Debris*, NAS A-STD-8719.14A, 25 May 2012, are addressed in this document; sections 9 through 14 are in the domain of the launch provider and are addressed by others.

<b>RECORD OF REVISIONS</b>		
<b>REV</b>	<b>DESCRIPTION</b>	<b>DATE</b>
0	Original submission	June 2018

The following table summarizes the compliance status of the ThinSat-1A through ThinSat-1L spacecraft. They all are fully compliant with all applicable requirements.

<b>Requirements</b>	<b>Compliance Assessment</b>	<b>Comments</b>
4.3-1a	Not Applicable	No planned debris release
4.3-1b	Not Applicable	No planned debris release
4.3-2	Not Applicable	No planned debris release
4.4-1	Compliant	Batteries incapable of debris producing failure
4.4-2	Compliant	Batteries incapable of debris producing failure
4.4-3	Not Applicable	No planned breakups
4.4-4	Not Applicable	No planned breakups
4.5-1	Compliant	

**Table 1 Compliance Assessment per Requirement**

## Section 1: Mission Overview

The overall goal of the ThinSat-1 mission, is to orbit 12 spacecraft collectively holding 60 small experiments, to advance STEM education, and promote space science research and systems engineering for grades 4 – 12 and universities. It includes approximately 70 schools from nine states. Each student team will analyze the data collected by their experiment and submit a report detailing their findings. The students will track their experiment and receive data in near real time through the Globalstar network, feeding data to the Space Data Dashboard website. Online content and resources will enhance the educational experience.

The 12 satellites, ThinSat-1A through ThinSat-1L, will be launched as a secondary payload aboard the NG-10 on the Antares second stage, from the mid-Atlantic Regional Spaceport, Wallops Island, Virginia, November 17, 2018. The satellites will be inserted into Extremely Low Earth Orbit (ELEO), at 250 km apogee and 203 km perigee, on an inclination from the equator of 51.6 degrees. They will be deployed from 3 Canisterized Satellite Dispensers (CSD) mounted externally on the second stage of the launcher; the spacecraft will deploy in 4 satellites per CSD, and after the solar activated burn-wire is effectuated, these satellites will unfold accordion style. The nominal operation plan is that transmission will begin upon deployment, and cease less than 17 days later, when de-orbiting occurs.

## Section 2: Spacecraft Description

Each spacecraft is comprised of 3, 5 or 6 ThinSat units, one unit per experiment. Figure 1 shows a typical single unit. Three of the units have two frames layered together containing a single payload, Figure 2. Figures 3, 4, and 5 show dimensions of each spacecraft type.

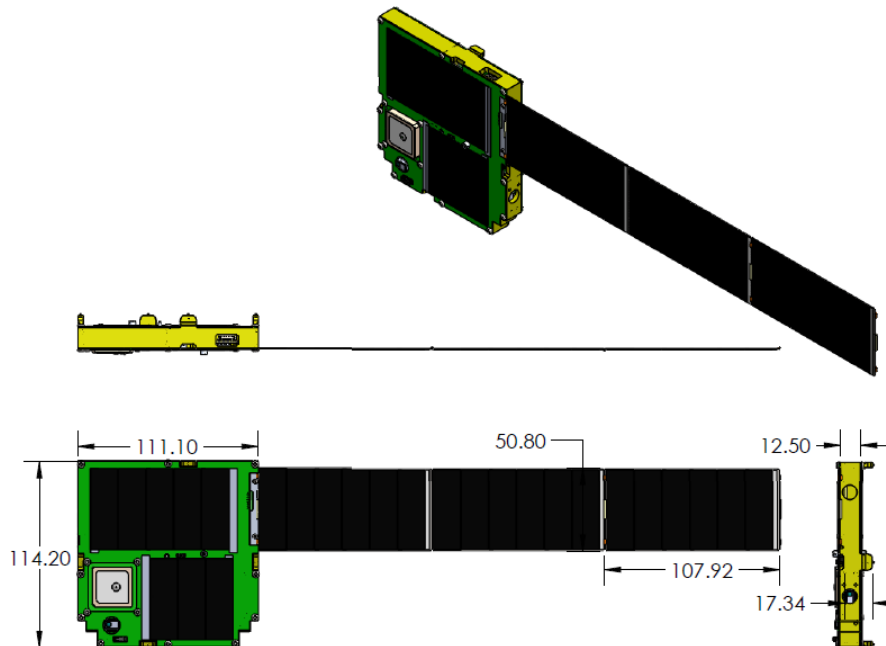

**Figure 1 Single Frame ThinSat Unit Detail, Dimensions in mm**

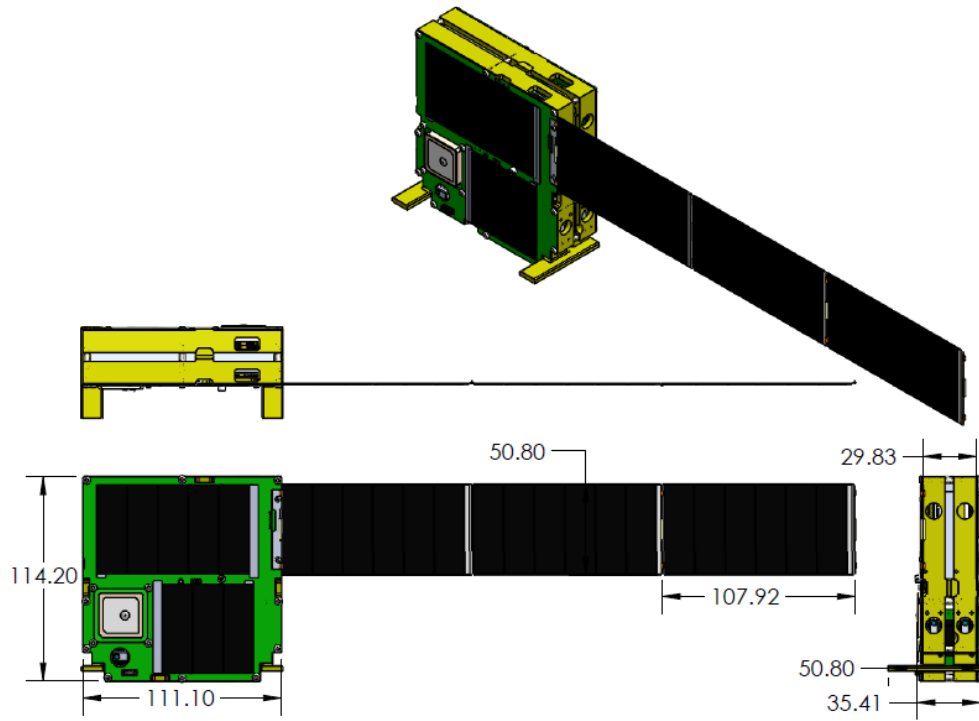

**Figure 2 Double Frame ThinSat Unit Detail, Dimensions in mm**

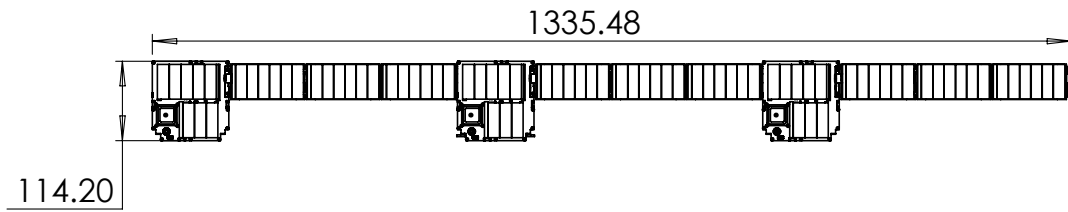

**Figure 3 ThinSat 3T Spacecraft, Dimensions in mm**

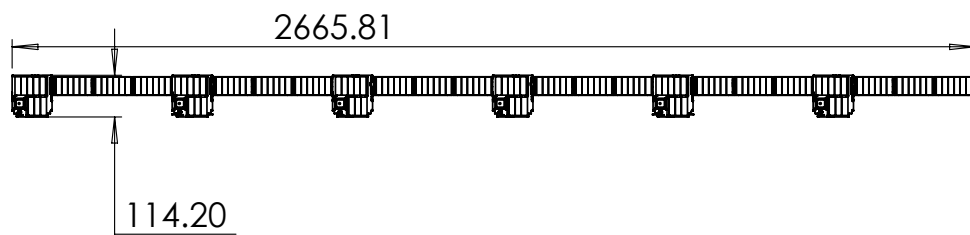

**Figure 4 ThinSat 6T Spacecraft, Dimensions in mm**

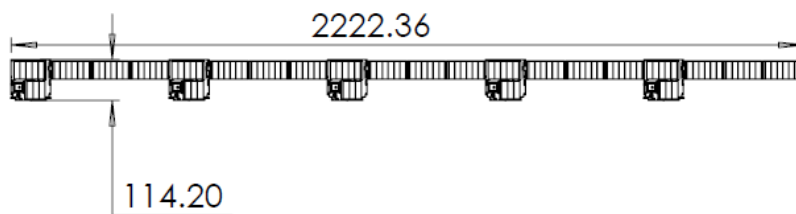

**Figure 5 ThinSat Double Frame Plus 4T Spacecraft, Dimensions in mm**

A unit is comprised of a single or double thickness aluminum frame as shown in Figures 1 and 2 above, printed circuit boards and small components including radio, antenna, and batteries, and the accordion folding photovoltaic panels.

The Appendix lists all of the components in each spacecraft, with the characteristics of each.

### **Hazards**

There are no pressure vessels, hazardous, or exotic materials.

### **Batteries**

The Tenergy Model 925050 pouch type cell, uses Polymer Li-ion chemistry. It stores 2200 mAh at 3.7 volts. The UL listing number of the battery is SR925959 (30256-0). It is used with a battery circuit protection module providing over-charge/over-current protection and over-discharge circuitry.

Tests have been conducted to demonstrate compliance with JSC EP-WI-032 “Statement of Work: Engineering Evaluation, Qualification and Flight Acceptance Tests for Lithium-ion Cells and Battery Packs for Small Satellite Systems.”

### **Section 3: Assessment of Spacecraft Debris Released during Normal Operations**

The assessment of spacecraft debris requires the identification of any object (>1 mm) expected to be released from the spacecraft any time after launch, including object dimensions, mass, and material.

Section 3 requires rationale/necessity for release of each object, time of release of each object, relative to launch time, release velocity of each object with respect to spacecraft, expected orbital parameters (apogee, perigee, and inclination) of each object after release, calculated orbital lifetime of each object, including time spent in Low Earth Orbit (LEO), and an assessment of spacecraft compliance with Requirements 4.3-1 and 4.3-2.

No releases are planned, therefore this section is not applicable.

### **Section 4: Assessment of Spacecraft Intentional Breakups and Potential for Explosions.**

There are NO plans for designed spacecraft breakups, explosions, or intentional collisions.

The probability of battery explosion is very low, and, due to the very small mass of the satellites and their short orbital lifetimes the effect of an explosion on the far-term LEO environment is negligible, per [HQ OSMA Policy Memo/Email to 8719.14: CubeSat Battery Non-Passivation, Suzanne Aleman to Justin Treptow, 10, March 2014](#)

The batteries meet Reg. 56450 (4.4-2), per this reference, by virtue of the HQ OSMA policy regarding battery disconnect stating "Cube Sats as a satellite class need not disconnect their batteries if flown in LEO with orbital lifetimes less than 25 years."

Passivation of the batteries at end of mission is provided for in the command structure. However, the low amount of energy stored and small battery cells prevents a catastrophic failure; so that passivation at EOM is not necessary to prevent an explosion or deflagration large enough to release orbital debris. In addition, the plan is that the mission continues for the two weeks or less from deployment until demise, so that the spacecraft will demise before end of mission.

The spacecraft are being deployed from a low altitude, so any unanticipated debris created will have negligible effects to the space environment.

Assessment of spacecraft compliance with Requirements 4.4-1 through 4.4-4 shows that the ThinSats are compliant.



## Section 5: Assessment of Spacecraft Potential for On Orbit Collisions

Calculation of spacecraft probability of collision with space objects larger than 10 *cm* in diameter during the orbital lifetime of the spacecraft takes into account both the mean cross sectional area (MCSA) and orbital lifetime.

This analysis considers both the nominal case where all of the spacecraft deploy and unfold, and aerodynamic forces orient them in the ram direction as planned, and the contingent cases where they do not unfold, and/or they tumble instead of orienting.

### Case 1: Deployed with Aerodynamic Stabilization (Nominal)

Per NASA STD-8719.14, “..an object may be considered to be tumbling randomly, or it may be assumed to have a stable attitude relative to the velocity vector.” At the altitude deployed, atmospheric drag will be significant and is expected to stabilize attitude with minimal cross section in the ram direction.

Calculation of effective cross sectional area in stable flight at the velocities and altitudes addressed, must take into account the lack of interaction between atoms and molecules in the atmosphere at the low density. Drag interaction with the spacecraft is dominated by Brownian motion and thermal velocity. The thermal velocity of the atmospheric constituents is comparable to that of the spacecraft, so as the “train” of 3, 5 or 6 units passes through the atmosphere, fills in behind the first unit edge, and the second, third and every unit experiences drag comparable to the first unit, in proportion to the area presented..

Thus in stabilized flight, the mean cross sectional area for drag purposes, and considering a perfectly rigid body presenting minimum cross section with zero angle of attack, would be the area of the faces of each of the external frames in the ram direction. From Figures 1 and 2, this would be

Config Type	Diagram	Cross Sectional Area, m <sup>2</sup>
1	ThinSat 3T	0.00428
2	ThinSat 6T	0.00857
3	ThinSat Double Plus 4T	0.00947

**Table 2 MCSA for ThinSat Configurations, Deployed and Stabilized**

For each of the 12 spacecraft, the total mass, obtained by summing the masses of the components of the spacecraft as shown in the Appendix, was used to determine the Area to Mass ratio for each, shown in the following Table 3. Table 3 also shows the orbit lifetime, and the probability of collision, provided by the DAS calculations. See Appendix for DAS Analysis Input Data and Output Results. The longest lifetime is about 16 days. If further analysis were done to take into account nonzero angle of attack, or oscillations, the lifetime would be reduced.

Spacecraft Name	Config Type	Area m <sup>2</sup>	Mass kg	Area/Mass m <sup>2</sup> / kg	Orbit Lifetime Years (DAS)	Orbit Lifetime Days (DAS)	Probability of Collision (DAS)
ThinSat-1A	3	.00947	1.95	0.00486	0.038	13.9	0
ThinSat-1B	1	.00428	1.09	0.00393	0.044	16.1	0
ThinSat-1C	2	.00857	2.11	0.00406	0.044	16.1	0
ThinSat-1D	2	.00857	2.2	0.00390	0.044	16.1	0
ThinSat-1E	3	.00947	2.16	0.00438	0.038	13.9	0
ThinSat-1F	2	.00857	2.11	0.00406	0.044	16.1	0
ThinSat-1G	1	.00428	1.1	0.00389	0.044	16.1	0
ThinSat-1H	2	.00857	2.11	0.00406	0.044	16.1	0
ThinSat-1I	3	.00947	2.15	0.00440	0.038	13.9	0
ThinSat-1J	2	.00857	2.2	0.00390	0.044	16.1	0
ThinSat-1K	1	.00428	1.1	0.00389	0.044	16.1	0
ThinSat-1L	2	.00857	2.14	0.00400	0.044	16.1	0

**Table 3**  
**Area to Mass Ratio, Lifetime and Probability of Collision for each Spacecraft,**  
**Deployed and Stable**  
**Assumed RAAN and Argument of Perigee both 0 Degrees**  
**Initial Apogee 250 Perigee 203**

## Case 2: Deployed and Tumbling

A deployed, tumbling ThinSat can be regarded as a complex object. The formula for the MCSA of a complex object, tumbling, is given by NASA STD-8719.14.

$MCSA = (A_{max} + A_1 + A_2)/2$ , where

$A_{max}$  is the area of the orthogonal view with the greatest area

$A_1$  and  $A_2$  are the areas of the other two orthogonal views

From this formula, the deployed MCSA of each of the 3 configurations are given in table 4. All dimensions given are in square meters.

Config Type	Diagram	A <sub>max</sub>	A <sub>1</sub>	A <sub>2</sub>	MCSA
1	ThinSat 3T	0.0874	.0044	.00143	.0466
2	ThinSat 6T	0.175	.0088	.00143	.0925
3	ThinSat Double Plus 4T	0.146	.0092	.00376	.0793

**Table 4 MCSA for ThinSat Configurations, Deployed and Tumbling**

For each of the 12 spacecraft, the total mass of the components shown in the Appendix was used to determine the area to Mass ratio for each, shown in the following table 5. Table 5 also shows the orbit lifetime, and the probability of collision, provided by the DAS calculations. See Appendix for DAS Analysis Input Data and Output Results. The tumbling case, which is not the expected case, yields significantly reduced lifetimes compared to the nominal case.

Spacecraft Name	Config Type	Deployed and Tumbling MCSA m <sup>2</sup>	Mass kg	MCSA/Mass m <sup>2</sup> / kg	Orbit Lifetime Years	Orbital Lifetime, Days	Probability of Collision
ThinSat-1A	3	.0793	1.95	0.04068	0.005	1.8	0
ThinSat-1B	1	.0466	1.09	0.04276	0.005	1.8	0
ThinSat-1C	2	.0925	2.11	0.04384	0.005	1.8	0
ThinSat-1D	2	.0925	2.2	0.04205	0.005	1.8	0
ThinSat-1E	3	.0793	2.16	0.03672	0.005	1.8	0
ThinSat-1F	2	.0925	2.11	0.04384	0.005	1.8	0
ThinSat-1G	1	.0466	1.1	0.04237	0.005	1.8	0
ThinSat-1H	2	.0925	2.11	0.04384	0.005	1.8	0
ThinSat-1I	3	.0793	2.15	0.03690	0.005	1.8	0
ThinSat-1J	2	.0925	2.2	0.04205	0.005	1.8	0
ThinSat-1K	1	.0466	1.1	0.04237	0.005	1.8	0
ThinSat-1L	2	.0925	2.14	0.04322	0.005	1.8	0

**Table 5  
Area to Mass Ratio, Lifetime and Probability of Collision for each Spacecraft,  
Deployed and Tumbling**

### Case 3: Un-Deployed With Aerodynamic Stabilization

The longest orbit lifetime would result if the entire cluster did not deploy, and if it stabilized with the minimum area face in the direction of flight. This yields an area of 0.111 x 0.114, or 0.013 m<sup>2</sup> for each cluster. Given the same area, the cluster with the greatest mass would have the longest orbit lifetime. From Table 6, the maximum orbit lifetime in this contingency case, which is the maximum for all cases considered, would be 32 days.

Launcher Tube	Spacecraft in Un Deployed Cluster	Area, m <sup>2</sup>	Mass of Cluster	Area to Mass Ratio	Orbit Life Years	Orbit Life Days	Probability of Collision
CSD-1	A, B, C, D	0.013	7.35	.00177	0.088	32	0
CSD-2	E, F, G, H	0.013	7.48	.00174	0.093	32	0
CSD-3	I, J, K, L	0.013	7.59	.00171	0.093	32	0

**Table 6 Orbit Lifetime and Probability of Collision, Un-Deployed and Stable**

#### Case 4: Un-Deployed with Tumbling

As a contingency we consider the unexpected case where all of the spacecraft, when ejected from the launcher tube, remained un deployed, e.g., do not unfold, and tumble. The cluster can be regarded as a convex object. The formula for the MCSA of a complex object, tumbling, is given by NASA STD-8719.14.

$$\text{MCSA} = \text{Surface Area} / 4$$

From the dimensions given in Case 3,

$$\text{MCSA} = \{[2 * (0.111 * 0.114)] + [2 * (0.111 * 0.262)] + [2 * 0.114 * 0.262]\} / 4$$

$$= 0.036 \text{ m}^2$$

This yields from DAS, a lifetime of 13.9 days.

Launcher Tube	Spacecraft in Un Deployed Cluster	MCSA, m <sup>2</sup>	Mass of Cluster	Area to Mass Ratio	Orbit Life Years	Orbit Life Days	Probability of Collision
CSD-1	A, B, C, D	0.036	7.35	.00490	0.038	13.9	0
CSD-2	E, F, G, H	0.036	7.48	.00481	0.038	13.9	0
CSD-3	I, J, K, L	0.036	7.59	.00474	0.038	13.9	0

**Table 7 Orbit Lifetime and Probability of Collision, Un Deployed and Tumbling**

#### Review of All Cases

In summary, the probability of any collision, in any configuration, with debris or meteoroids greater than 10 cm in diameter is “less than 0.00000”, per DAS for any configuration. This satisfies the 0.001 maximum probability requirement 4.5-1.

The spacecraft have no capability nor have plans for end-of- mission disposal, therefore requirement 4.5-2 is not applicable.

Assessment of spacecraft compliance with Requirements 4.5-1 shows all spacecraft to be compliant. Requirement 4.5-2 is not applicable to this mission.

## **Section 6: Assessment of Spacecraft Postmission Disposal Plans and Procedures**

The spacecraft all will naturally decay from orbit within 25 years after end of the mission, satisfying requirement 4.6- 1.

Planning for spacecraft maneuvers to accomplish post-mission disposal is not applicable. Disposal is achieved via passive atmospheric reentry.

### Summary of DAS 2.1.1 Orbital Lifetime Calculations:

DAS inputs are: 250 km maximum apogee 203 km maximum perigee altitudes with an inclination of 51.6° at deployment no earlier than November 2018.

From Section 5, Table 3, in the nominal operation case, the lifetimes of the 12 spacecraft are estimated to be between 13 and 16 days, depending on the Area / Mass ratio of each.

As an extreme outer limit for orbit lifetime, the contingency mode of total non deployment of an entire canister compliment of satellites, clustered as when contained in the canister and assumed stable in flight, yields a value of 32 days. There is no mode in which any of the spacecraft would be estimated to stay in orbit longer than 32 days even without deploy.

The assessment of the spacecraft illustrates they are compliant with Requirements 4.6-1 through 4.6-5.

## Section 7: Assessment of Spacecraft Reentry Hazards

A detailed assessment of the components of the spacecraft was performed using DAS 2.1.1, to verify Requirement 4.7-1. See Appendix for a complete log of DAS inputs and outputs for all cases. The analysis provides a bounding analysis for characterizing the survivability of a component during re-entry. It is conservative in that when it shows terminal energy of a component surviving reentry, it does not consider any loss material from ablation or charring. Both of these may for some materials decrease the mass and dimensions of the re-entering components, reducing the risk below that calculated.

The only surviving components are the Separation Switch, and the Solar Foldout, as shown in Table 8. Each of the 12 spacecraft contains between 3 and 6 of each of these, for a total of 60 each.

Surviving Component	Original Mass, kg	Terminal Energy, Joules	Casualty Area	Spacecraft Risk of Human Casualty
Separation Switch	<b>0.0003</b>	<b>0</b>	<b>1.84</b>	<b>1:100000000</b>
Solar Foldout	<b>0.034</b>	<b>1</b>	<b>2.66</b>	

**Table 8: Surviving Component Analysis**

If a component survives to the ground but has less than 15 Joules of kinetic energy, it is not included in the Debris Casualty Area that inputs into the Probability of Human Casualty calculation. This is why all of the spacecraft have a calculated Risk of Human Casualty from DAS, of 1:100000000. The maximum terminal energy among all the surviving components is 1 Joule.

The majority of components demise upon reentry and all spacecraft comply with the less than 1:10,000 probability of Human Casualty Requirement 4.7-1.

The ThinSats thus are in compliance with Requirement 4.7-1 of NASA-STD-8719.14A.

**Section 8: Assessment for Tether Missions**

No tethers are used. Requirement 4.8-1 is satisfied.

**Section 9 through 14:**

ODAR sections 9 through 14 pertain to the launch vehicle, and are not covered here.



## Appendix

The document “Appendix to ThinSat-1 ODAR: DAS Activity Log 0718”, file [ActivityLog.pdf](#), is incorporated by reference into this document.