

## Mars Outpost Experiment Technical Description

The overall goal of the Mars Outpost experiment, is to demonstrate metal cutting in space, to explore the feasibility of reusing abandoned space vehicles.

This license request is to replace the current license, which is 0022-EX-ST-2021, call sign WR9XRA. An STA is requested because the mission duration is less than 1 day. The new license is requested because the number of ground stations supporting the mission has been expanded from those named in the original license, in order to have greater assurance that the experimental data will be recovered during the few hours of the mission lifetime before the second stage carrying the experiment, de orbits. The expanded list of ground stations are listed in the comms section of this document. And the No Earlier Than launch date has slipped, so the dates requested for the license period have changed. These are the only changes to the mission plan.

The experiment will be launched on the second stage of a SpaceX Falcon 9 launch vehicle (“Stage 2”), from Cape Canaveral, FL, no earlier than December 1, 2021, on a dedicated sun-sync rideshare mission. The experiment remains attached to the second stage throughout the mission and during de-orbit. Stage 2 will be inserted into a circular orbit at about 545 km, 97.5 degrees inclination.

### **Key Milestones:**

- Second stage engine cutoff will occur upon attaining orbit, about 9 minutes after launch (L+9m). At this time, experiment initiation and radio transmission will be enabled by the Stage 2 on board computer, and the experiment will begin. After this, all activities are time based, per logic in the Stage 2 onboard computer.
- Transmission to the first downlink site will begin approximately L+33m.
- After that, satellite payloads will be deployed.
- Transmission to the second downlink site will begin at L+90m.
- Stage 2 will be de-orbited at L+120m.

The experiment is approximately 23” x 27” (58 cm x 67 cm) and weighs 245 lbs (111 kg).

# Mars Outpost Experiment Technical Description

**Figure 1 Mars Outpost Overview**

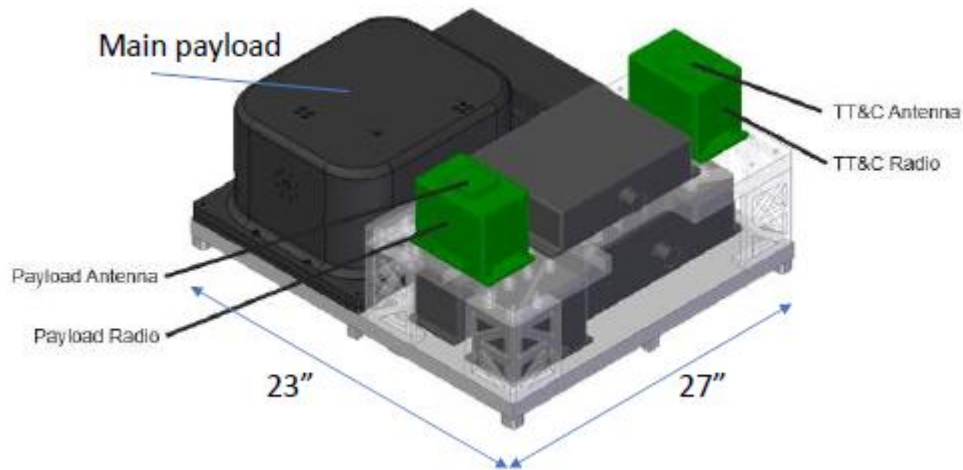

The experiment contains the following systems:

**Communications Subsystem (COMMS):**

The TT&C Transceiver is a Syrlinks EWC31, operating in S Band, using a patch antenna. The payload transmitter is a Syrinks EWC27, operating in X band, using a patch antenna.

Ground communications will be provided by the stations listed in Table 1. McMurdo was part of the application for the current license, others are new. Details about these ground stations are found in other exhibits.

**Table 1 Ground Stations Supporting Mars Outpost**

Station Name / Location	S Band Up	S Band Down	X Band
NEN McMurdo Station, Ross Island, Antarctica	X	X	X
NEN White Sands, New Mexico	X	X	
US Army SMDC Mobile CubeSat Command and Control (MC3) Ground Station, Alabama	X	X	X
DoD Human Spaceflight Program MC3, Texas		X	X
University of New Mexico Ground Station		X	X
Atlas Space Operations, New Mexico			X

## Mars Outpost Experiment Technical Description

**Electrical Power Subsystem (EPS):** Power is supplied by a pair of 26 Ah Li-Ion (type NMC) 8-cell blocks in parallel using Z-fold design for size and weight reduction.

**Thermal Control Subsystem (TCS):** Passive heat sinking provides effective heat dissipation during this short duration mission.

**Structure Subsystem:** Aluminum

**Propulsion Subsystem:** No propulsion subsystem is included.

**Payload Subsystem:** The main payload system is a cutting experiment. A video camera will record a high speed cutting wheel cutting a coupon of CRES 316 stainless steel. The experiment will demonstrate cutting characteristics in zero g and vacuum.