

## Mars Outpost Experiment Technical Description

The overall goal of the Mars Outpost experiment, is to demonstrate metal cutting in space to explore feasibility of reusing abandoned space vehicles.

The experiment will be launched on the second stage of a SpaceX Falcon 9 launch vehicle (“Stage 2”), from Launch Complex 4E (LC-4E), Vandenberg Air Force Base, between December 1, 2020, and January 31, 2021, on a dedicated sun-sync rideshare mission. The experiment remains attached to the second stage throughout the mission and during de orbit. Stage 2 will be inserted into a circular orbit at about 600 km circular, on an inclination from the equator of about 98 degrees. Transmission and experiment initiation will be enabled by the Stage 2 on board computer after deployment of satellite payloads from Stage 2, estimated to be about 45 minutes after second stage engine cutoff, and cease when the experiment is completed and data downloaded, about 5 hours later. After completion of the mission, Stage 2 will be de-orbited.

The experiment is approximately 23” x 27” (58 cm x 67 cm) and weighs 245 lbs (111 kg).

**Figure 1 Mars Outpost Overview**

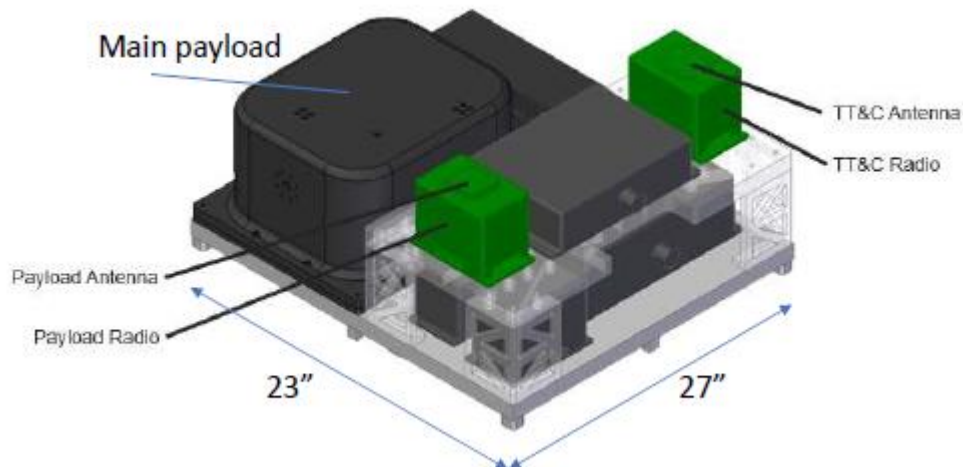

# Mars Outpost Experiment Technical Description

The experiment contains the following systems:

## **Communications Subsystem (COMMS):**

The TT&C Transceiver is a Syrlinks EWC31, operating in S Band, using a patch antenna.

The payload transmitter is a Syrinks EWC27, operating in X band, using a patch antenna.

**Electrical Power Subsystem (EPS):** Power is supplied by a pair of 26 Ah Li-Ion (type NMC) 8-cell blocks in parallel using Z-fold design for size and weight reduction.

**Thermal Control Subsystem (TCS):** Passive heat sinking provides effective heat dissipation during this short duration mission.

**Structure Subsystem:** Aluminum

**Propulsion Subsystem:** No propulsion subsystem is included.

**Payload Subsystem:** The main payload system is a cutting experiment. A video camera will record a high speed cutting wheel cutting a coupon of CRES 316 stainless steel. The experiment will demonstrate cutting characteristics in zero g and vacuum.