



*Lociva
15330 Riding Club Drive
Haymarket
VA
20169
(703)753-6000*

Product: EdgeCentrix Deployable LTE 4G Macro Cell System (LMCS)

Submitted by: Lociva

Address: 15330 Riding Club Dr
Haymarket
VA 21069

Telephone: (703) 753-6000

Facsimile: (703) 753-6200

POC: Paul Christoforou

Date: Jan 2014



LOCIVA

Lociva is a mobile communications technology firm based in Northern Virginia, providing high performance UMTS and LTE mobile networks supporting voice, messaging (SMS and MMS) and high-speed packet data (HSDPA/LTE) services, specialized telecommunications solutions and consulting services:

- Wireless voice and packet data technology, (GSM, MAP/SS7, GPRS/EDGE, CDMA, UMTS, HSDPA, WiMax 802.16d/e, satellite, SIP, T1/E1)
- Wireless data and messaging application integration services
- Security provisioning on wireless networks and devices
- Network design, deployment and optimization
- Customized software and hardware for customer specific functionality/requirements

Contact Details

Paul Christoforou
15330 Riding Club Drive
Haymarket
VA 20169
Tel: (703) 753-6000
Fax: (703) 753-6200
Email: pac@lociva.com



EdgeCentrix LTE Macro Cell System (LMCS)

The EdgeCentrix LMCS is a complete LTE network in a rack mount enclosure that comprises a Nokia Solutions & Networks (NSN) LTE radio with a server based EdgeCentrix LTE packet core (EPC).



The LMCS supports the following features:

- Nokia Flexi LTE macro cell system
 - Single or Three sector configuration
- FD-LTE Band options; 1, 3, 4, 5, 7, 8, 12, 14, 17, 20, 41
- TD-LTE Band options: 41
- 64 to 640 simultaneous active users per LMCS*
- Integrated LTE packet core (HSS, MME, PGW, SGW)
- Optional LTE-Advanced Support with Multiple RF Modules

Optional LTE packet core features

- Optional EPC features
 - Centralized HSS for subscriber authentication and management
 - LTE Handover (S1 and MME)
 - LTE Relay
 - SMS over LTE
 - VolTe – LTE voice bearers terminate to SIP G729
 - Multicast support – IGMP
 - MME mesh networking between multiple systems
- 7U transportable rack mount package
 - Weight: 140 lbs (excl. case)
 - Power: 600W 48V
 - Dimensions: 22" w x 17" h x 20" d
 - Output power: up to 2 x 60W (MIMO)
 - Temperature range (-35 to +55 C ambient)
 - Interfaces: Antenna Connections (2), Power (1), Ethernet (1)
- Shared throughput: 150Mbps per sector – up to 450Mbps per system (3 sectors)
- Shared throughput LTE-Advanced: up to 300Mbps per sector



EdgeCentrix LMCS Application Support

The EdgeCentrix LMCS will provide high-speed 4G LTE data services to standard COTS subscriber devices supporting LTE services. Applications resident on LTE subscriber devices will provide a secure environment for task specific functions – providing a complete LTE “eco-system” that provides voice, push-to-talk, group calling, shared video streaming, in-network roaming, security and other valuable services.

Specific Applications Validated on the EdgeCentrix LMCS

- Dual VPN application (MACE) - a security handset client allows all data to be secured with a double VPN tunnel to a centralized server – client activation typically takes less than 30 seconds to set up the double VPN tunnel allowing secure voice and data services
- Shared Video distribution applications – supports shared video and desktop streaming between multiple subscriber devices (handsets, PC’s) on any routable network – and across the internet if needed.
- Push-To-Talk applications – predefine user groups and channels – SOP similar to existing voice radio networks
- Net-Warrior applications
- Medical support applications

Handset/ Tablet interoperability

- Multi band (cross band) modems provide local LAN and WiFi connectivity to legacy devices
- Smart phones, tablets provide connection to the internet or local application servers
- Dual SIM converters allow use of “bring your own devices”

EdgeCentrix LMCS Integrated Application Server

Integrated Virtualized Application Server – VMware ESX – Multiple OS

- EdgeCentrix LTE Core Server
- PTT Voice Service Server – supported via handset based PTT clients to a local or centralized SIP gateway
- Video Sharing Services Server – handset based application connects to Video Sharing server
- SIP Gateway Server
- Dual VPN Security Server – dual VPN security services
- Situational Awareness Server – with local hosted map database



EdgeCentrix LTE Packet Core

Provides a complete LTE network core solution for portable and transportable mobile communication systems, integrating HSS/MME/SGW/PGW functions. The EdgeCentrix system is entirely IP based supports LTE eNodeB's for radio access (RAN) providing voice, SIP interface and high speed data services without the need for additional 3rd party equipment.

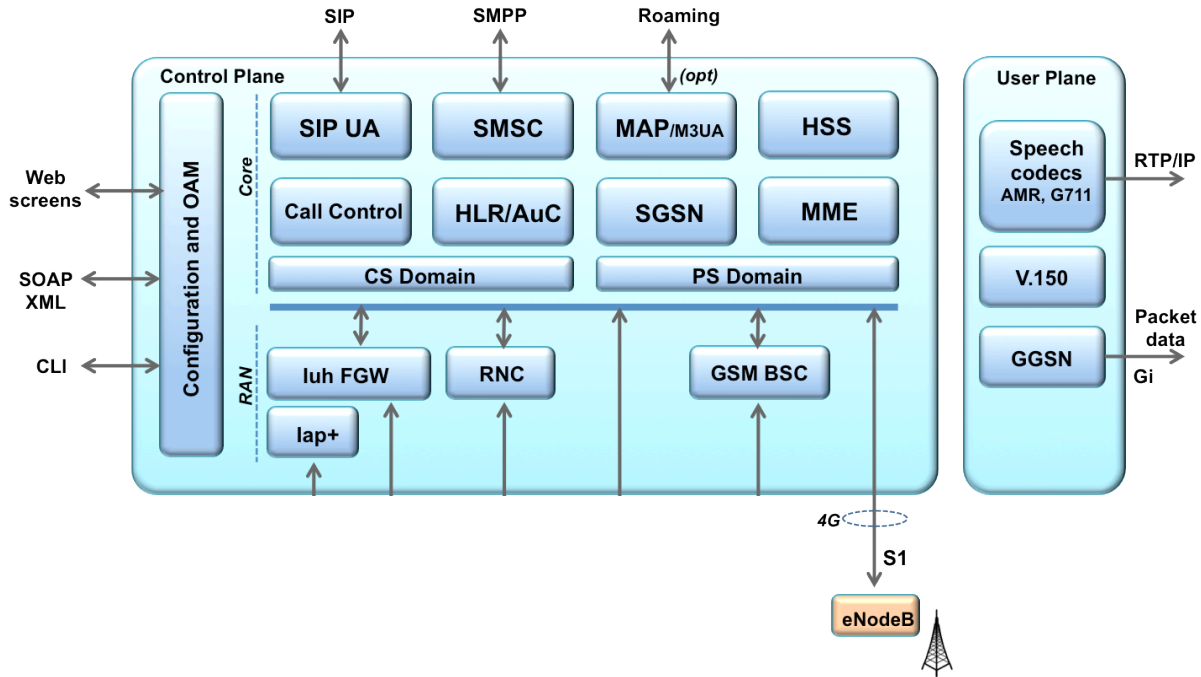

EdgeCentrix LTE Packet Core Features

The EdgeCentrix SoftCore is a standalone network solution for small scale and portable LTE deployments, integrating HSS, MME, SGW and PG. The EdgeCentrix SoftCore is entirely IP based, and currently supports multiple OEM LTE eNodeB's for radio access providing voice (with SIP interconnect) and data services without the need for additional 3rd party equipment.

Specifications

Integrated LTE CN elements	HSS, MME, SGW, PGW
Supported eNodeB's	NSN, QuCell and other OEM radios
PS & HSDPA services	Integral packet core drops user data to local LAN.
Authentication and ciphering	UMTS and GSM authentication challenge modes. Standard LTE/UMTS AUTN, CK, IK and AUTS support.
Hardware platforms	Small i86 ITX or ARM9 boards to rack-mount HP ProLiant servers, depending on capacity requirements.
Management and provisioning	Command line base tools

The EdgeCentrix LTE packet core provides the functional capability defined in this document and in the attached product data sheet. Specifically the system currently supports the following capabilities

- Multiple LTE access points (FAP's) and eNodeB's
- Integral HSS, MME, PGW/SGW functions
- USIM SIM support with Milenage authentication
- Real time OAM monitor for handset registration, authentication and attach/detach
- OAM management status
- CLI for system configuration and management
- Optional web browser interface for subscriber configuration and management



- Trace file logging
- Linux OS – SoftCore process runs as a service with auto start and restart
- Automatic IP and routing table management
- Integrated NAT to facilitate PS service provisioning

EdgeCentrix LTE Packet Core Customization

The QX3 SoftCore can be adapted from its basic core functionality to satisfy (maybe non-standard) requirements from our customers so that they can meet their own technical and business objectives. Unlike traditional LTE/UMTS network vendors, we can implement new features quickly and cost-effectively, and so respond dynamically to our customer's wishes.

EdgeCentrix LTE Core - Optional Features

The features illustrated below are options to the entry level EdgeCentrix Network Core functionality describe above and may be licensed at time of purchase or at a future date

- Centralized HSS – allows centralized subscriber management and authentication
- Local 'Cached' HSS – allows the LMCS to use cached subscriber database in the event of backhaul failure – allows continual use of the LMCS
- LTE Handover – allows MME and X2 LTE handover between multiple LTE radios
- Multicast - IGMP - supports situational awareness applications – bi-directional
- VoLTE: supports voice calls from the LTE handset dialler – on the LTE 4G network – calls terminate to a local SIP gateway on the PSTN or private SIP network
- SMS over LTE
- LTE Relay – allows multiple LTE systems to establish IP connections automatically between themselves
- LTE Meshing –allows multiple LTE systems to use external IP networks to automatically set up IP connections between systems. In addition MME to MME handover will allow the PDP-context for active data sessions to retain their IP address after handover allowing continuous streaming within the private network.

Centralized HSS

The EdgeCentrix Centralized HSS System supports the "Diameter S6a" interface between remotely deployed EdgeCentrix LMCS Systems and the EdgeCentrix Centralized HSS System for centralized subscriber management and authentication.

In the event of a backhaul failure the Diameter S6a interface on the remote EdgeCentrix LMCS Systems can use a cached version of the HSS stored locally on the EdgeCentrix LMCS System, so that it functions as a standalone system in the event of a backhaul failure

LTE Handover

Handover is supported on the S1 (MME) and X2 interface.

Multicast

Multicast will support IGMP broadcast capability in the EdgeCentrix LMCS System – this will interoperate with military multicast systems supporting Phone-Phone, Network-Phone and Phone-Network scenarios.

VoLTE "IMS Lite"

The EdgeCentrix Network Core supports a simplified version of VoLTE, which directly converts LTE voice calls to SIP for termination on a SIP gateway. The EdgeCentrix Network Core is configured to provide the P-CSCF address to the LTE subscriber device, which then registers with the specified 'P-CSCF', to make calls through it.

VoLTE calls made by a subscriber device appear as a call coming in on the SIP-IMS instance configured as the P-CSCF. Call handling and routing is normal and media is handled normally within the EdgeCentrix core and only transcoded if it is necessary to do so.

LTE SMS

SMS over LTE support is implemented in the EdgeCentrix Network Core



LTE Relay

LTE modems associated with the EdgeCentrix LTE MME/PGW system can be directed to connect automatically to other EdgeCentrix systems – allowing high speed IP connections to bridge the two networks – allowing subscribers to share services between the two systems.

LTE Macro Mobility

Macro Mobility is a separate feature, which combines MME to MME handover, and non-3GPP (EdgeCentrix custom) access methods to be able to transfer active data sessions between multiple EdgeCentrix Systems without the user (or applications) being aware.

An example scenario would involve different EdgeCentrix LMCS Systems deployed on different vehicles. A subscriber with an active data session on an EdgeCentrix LMCS System on Vehicle 1 is accessing a streaming video session

If another EdgeCentrix LMCS System arrives on Vehicle 2 in such a way that its radio coverage overlaps that from Vehicle 1 and if Vehicle 1 drives away, or if the subscriber walks towards Vehicle 2 such that the handset prefers the second system for its RF coverage - in this scenario, the subscribers active data session is transferred to the second EdgeCentrix LMCS system. IP engineering re-routing and such like is done such that the end-to-end IP data path from the handset remains the same.

MME Authentication

Actual authentication of users occurs when they first attach to an EdgeCentrix LMCS System. In the example above, when the subscriber data sessions are transferred from one system to another, authentication can be executed in 2 ways. Either the EdgeCentrix LMCS System on each vehicle has knowledge of all subscribers (SIM's) in the network or authentication is backhauled - using Diameter to the Centralized HSS System – a single location for subscriber SIM management.



LMCS System Architecture

The LMCS system comprises the EdgeCentrix LTE packet core (EPC) and and Nokia Siemens LTE eNodeB radio.

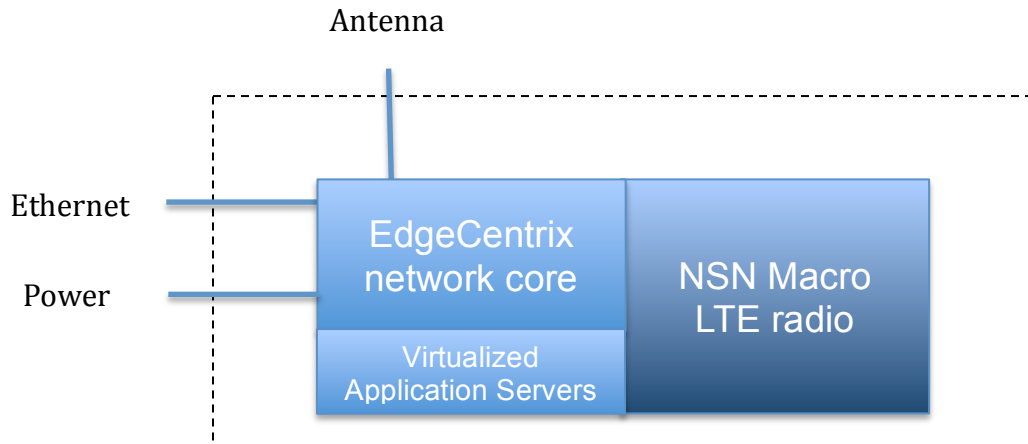

EdgeCentrix Centralized HSS Architecture

In this scenario the EdgeCentrix centralized HSS provides a common HSS for all remotely deployed EdgeCentrix LTE LMCS Systems for subscriber management and authentication

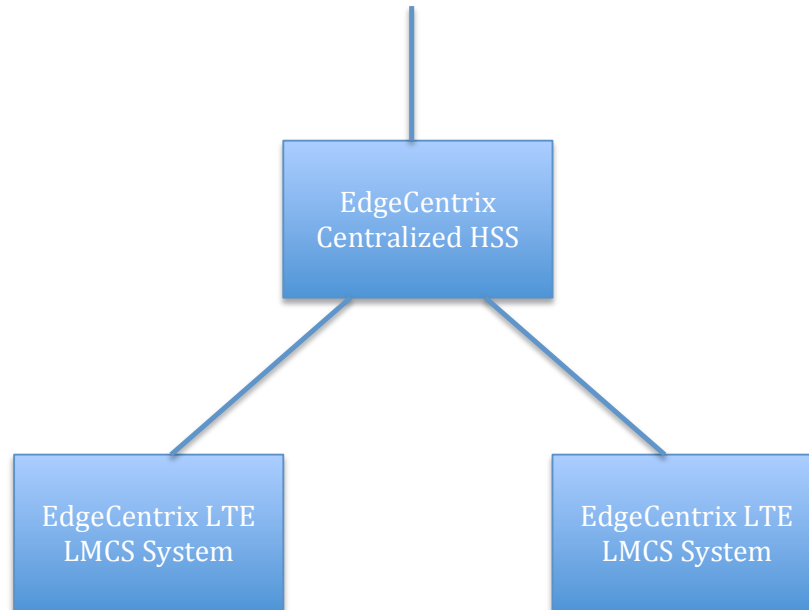

The Centralized HSS functions are described above



EdgeCentrix LTE Macro-Cell

The EdgeCentrix 4G LTE macro system is based on the Nokia Siemens eNodeB. The System Module controller (SMU) and RF module (RFU) are packaged in an IP67 outdoor enclosure illustrated below, which may be rack mounted. Power is provided via a power distribution module providing -48VDC. The LTE network core is deployed on a separate server, which may be co-located or remotely located with the system. Virtualized application servers may be deployed centrally on the LTE network core server.

Hardened connections to Power, Ethernet, fiber and antennas are provided on the system. The radio/baseband module may be deployed indoors or outdoors.

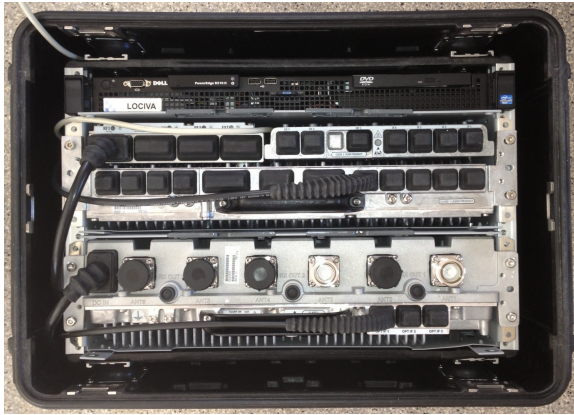

The LTE RAN is designed to provide macro coverage with up to MIMO 2 x 60W operation with up to 20MHz channel bandwidth – maximizing range and packet data throughputs with shared data throughput of 150Mbps per sector to subscriber handsets. The system is deployed quickly and simply providing operational coverage within 4 minutes of system switch on.

The LTE macro-cell supports high speed 4G LTE packet data sessions in various LTE FDD and TDD Bands

Key Features

Dimensions:	7RU 20" depth
Weight:	140lb (including external power supply adaptor)
Simultaneous Calls:	up to 640 simultaneous PS sessions (SW license)*
Throughput:	150Mbps shared throughput per sector – up to 450Mbps (for a three sector radio system)
Case:	IP67 weather proof aluminum enclosure
Mounting Options:	Rack, Pole or wall-mount options
External Interfaces:	Ethernet, DC power, Reset switch, Mesh antenna port LTE antenna ports
Indicators/OAM:	LED and remote management SW tools
Acoustic Noise:	Fans – convection cooling
Operating Temperature:	-35°C to 50°C
Energy Consumption:	<600W
LTE Bands:	FDD Band options; 1, 3, 4, 5, 7, 8, 12 14, 17, 20, 25 TDD Band options: 41
GPS for Location and Timing:	Yes
Max Transmit Power:	2 x 60W
PS performance:	4G LTE
Core Network Interface:	3GPP R8/9/10



EdgeCentrix Deployable 4G LTE Macro Cell System HW Configuration

EdgeCentrix Network Core HW

EdgeCentrix LTE SoftCore SW is preinstalled on a server with RAID disk configuration.

The SW is licensed by number of LTE eNodeB radio modules, and minimum 32 simultaneous PS sessions.

Alternative servers are available with IP67 rating if required

Select Network Core SW Options

Add LTE SMS, VoLTE and Multicast support

Centralized HSS, LTE Relay and future Meshing require purchase of multiple systems

eNodeB configuration

Specify band and number of sectors with Purchase Order

Subscriber capacity – can be increased to up to 640 users if needed – specific with purchase order

Each system includes a 1000W 48VDC power supply, power cables, optical cables, GPS antenna and cable, pole mount HW.

RF cables and antennas are not included. Masts, RF cables and Antennas may be quoted separately

System integration

IP connections to application servers to facilitate video, email and other such services on the handsets may be required. The radios will be preconfigured with customer supplied IP addresses and BTS ID's as required and will work out of the box on delivery.

Support

Telephone support: weekdays - M-F – 9am to 5pm EST

SW bug fixes: 6 months

HW warranty: 12 months

SW Support & Maintenance: 12 months – includes point code releases during support term



Lociva Standard Terms & Conditions for Purchase Orders

Whereas, a purchase order (the "PO") has been placed by purchaser, to purchase and license Equipment and Software, as defined above, (collectively, the "Products") and services from Lociva, located at 15330 Riding Club Dr, Haymarket, VA 20169, USA ("LOCIVA"), an authorized agent for ipaccess ltd (IPACCESS) and Zynetix Ltd. (ZYNETIX) manufacturers (MANUFACTURERS) of the Products defined above. The "Agreement" comprises the PO and these PO Terms & Conditions.

1. SCOPE.

In accordance with the PO issued by Purchaser and accepted by LOCIVA, LOCIVA shall: (a) sell, and deliver, as defined in Section 4.1, that Equipment so specified in the PO ("Equipment" being defined as the hardware component of each Product); (b) grant to Purchaser a perpetual, one-time transferable, non-exclusive, paid-up licence to use the Software (as defined in Section 7.1) on the terms and conditions set forth in Section 7; and (c) install and commission the infrastructure Products ("Installation Services") if such service is specified in the PO and provide other services specified in the PO (collectively "Services"). LOCIVA reserves the right to subcontract such portions of Services to qualified subcontractors of LOCIVA's choice as it may reasonable deem appropriate. Purchaser has the right to refuse such subcontractors with reasonable cause. In the case that the Purchaser advises LOCIVA that it wishes to refuse a subcontractor, LOCIVA shall be granted ten (10) working days to effect a remedy.

Acceptance of the PO must occur within five (5) working days after receipt by LOCIVA.

2. POs AND CONTRACT PRICE

2.1 The PO shall define the Products and Services required by Purchaser, the Contract Price, as defined below, and the required Delivery date. The PO shall incorporate these PO Terms & Conditions and no additional or different terms and conditions stated in the PO, any letter, or otherwise shall be binding unless expressly referred and agreed to in writing by LOCIVA and Purchaser. In the event of a conflict between these PO Terms & Conditions and those of the PO, even if the PO does not reference these PO Terms & Conditions, these PO Terms & Conditions shall control.

2.2 The contract price for each item of Equipment, Software or Services is as specified in the accepted PO (the "Contract Price") and shall be paid to LOCIVA in United States' dollars (US\$). The Contract Price includes delivery charges in accordance with LOCIVA's delivery obligations set forth in Section 4.1. Unless specifically stated in the accepted PO the Contract Price for Products does not include Installation Services.

2.3 Lociva reserves the right to adjust the Contract Price, as applicable when the validity period indicated on LOCIVA's quotation expires.

2.4 The Contract Price includes applicable purchase taxes or imposts, all of which shall be for Purchaser's account, but Purchaser shall not be required to pay any tax assessed on LOCIVA's income. For the avoidance of doubt, import duties shall be paid by LOCIVA.

3. PAYMENT TERMS.

3.1 Unless otherwise agreed in writing, payment of the Contract Price is due (subject to Section 10.2, without any right of set-off) as follows: 25% of the total Contract Price is due with Purchase Order (PO).

3.2 Purchaser may pay by certified check or transfer funds directly to LOCIVA's bank account.

4. DELIVERY TITLE & RISK.

4.1 All Equipment and Software will be delivered by LOCIVA DDP (Delivery Duty Paid), as defined in Incoterms 2000 ("Delivery").

4.2 Title to the Equipment shall pass to Purchaser on Delivery or Payment in full whichever is the later.

4.3 The Software shall at all times remain the exclusive property of the MANUFACTURER.

4.4 All risk of loss or damage to the Equipment and Software will pass to Purchaser upon Delivery.

4.6 LOCIVA will use reasonable efforts to meet Purchaser's requested delivery dates for Products and Services. LOCIVA may make partial deliveries but this shall not relieve Purchaser of its obligation to accept the remaining items. LOCIVA reserves the right to refuse, cancel or delay delivery to Purchaser if, after five (5) business days written notice, payment has not been made as required or guaranteed under this Agreement. In any event, LOCIVA shall not be liable for any direct, indirect, consequential, or special losses or damages (including, but not limited to, loss of income or profit and loss of data) that may be suffered by the Purchaser or by any other person for failure to deliver or for any delay or error in delivery of Products or Services for any reason whatsoever.

5. WARRANTY.

5.1 THE WARRANTIES SET FORTH IN THIS SECTIONS 5 ARE IN LIEU OF, AND LOCIVA HEREBY DISCLAIMS, ALL OTHER WARRANTIES AND CONDITIONS, WHETHER EXPRESS OR IMPLIED, INCLUDING WITHOUT LIMITATION THE IMPLIED TERMS OF SATISFACTORY QUALITY AND FITNESS FOR A PARTICULAR PURPOSE.

5.2 Subject to Sections 5.3 and 5.4, LOCIVA warrants that the Equipment sold to Purchaser under this Agreement shall, under normal use and service, be free from defects in materials and faulty workmanship, and that the Software licensed to Purchaser under this Agreement shall conform in all material respects to MANUFACTURERS published specifications therefore. The warranty period for any item of Equipment and related Software shall be six (6) months from delivery (the "Warranty Period").

5.3 LOCIVA's obligation and Purchaser's sole remedy under this warranty are limited to the replacement or repair, at LOCIVA's option, of the defective Equipment or Software within the Warranty Period. LOCIVA shall have no obligation to remedy any such defect if it can be shown that: (a) the Equipment or Software was altered, repaired, or reworked by any party other than LOCIVA without LOCIVA's prior written consent; (b) such defects were the result of Purchaser's or a third party's improper storage, mishandling, abuse, or misuse of the Equipment or Software; (c) such defects were

the result of Purchaser's or a third party's use of the Equipment or Software in conjunction with equipment electronically or mechanically incompatible or of an inferior quality; or (d) the defect was the result of damage by fire, explosion, power failure, or any act of nature.

5.4 In no event shall LOCIVA be obliged to provide on-site maintenance. Subject to the provisions of this warranty clause, defective parts must be returned within the Warranty Period by Purchaser DDP to LOCIVA's appointed repair facility and said defective parts will be promptly repaired or replaced by LOCIVA at no additional charge to Purchaser. In connection with such return by Purchaser, Purchaser shall comply with LOCIVA's Return Material Authorisation (RMA) procedures. LOCIVA shall deliver the repaired or replacement parts DDP to Customer's designated location. However, if there was no fault found (NFF) in the working condition of the Product, Purchaser shall pay such transportation costs along with LOCIVA's NFF charge of FIVE HUNDRED DOLLARS (\$500.00) per item. Risk of loss or damage shall pass to the receiving party on delivery. LOCIVA will charge Purchaser for any maintenance carried out which is not covered by the warranties contained in Section 5.2 or Section 5.5 at LOCIVA's then prevailing standard rates for such Services.

5.5 LOCIVA warrants that the Equipment or Software returned by LOCIVA following repair or replacement by LOCIVA shall be free from defects in materials and faulty workmanship and that the Software will conform in all material respects to LOCIVA's published specifications therefore for ninety (90) days from delivery or until the end of the Warranty Period, whichever is longer.

6. LIMITATION OF LIABILITY.

6.1 WITHOUT PREJUDICE TO SECTION 6.4, NEITHER LOCIVA NOR ANY OF ITS OFFICERS, DIRECTORS, EMPLOYEES, AGENTS, REPRESENTATIVES, SHAREHOLDERS, OR AFFILIATES (LOCIVA AND SUCH OTHER PERSONS, THE "LOCIVA PARTIES"), SHALL HAVE ANY LIABILITY TO PURCHASER FOR LOSS OF PROFITS, INCOME, REVENUE OR DATA, OR INCIDENTAL, CONSEQUENTIAL, INDIRECT OR PUNITIVE DAMAGES OR LOSSES ARISING FROM OR IN CONNECTION WITH THIS AGREEMENT, ANY PO PLACED PURSUANT TO THIS AGREEMENT OR ANY COLLATERAL CONTRACT, OR FROM OR IN CONNECTION WITH THE EQUIPMENT OR THE SOFTWARE OR THE USE THEREOF OR THE INABILITY TO USE THEM EITHER SEPARATELY OR IN COMBINATION WITH OTHER EQUIPMENT OR SOFTWARE, OR FROM OR IN CONNECTION WITH THE SERVICES, OR FROM ANY OTHER CAUSE, WHETHER CAUSED BY NEGLIGENCE, BREACH OF CONTRACT OR OTHERWISE.

6.2 Without prejudice to Sections 6.3 and 6.4, the liability of the LOCIVA Parties, taken as a whole, for each event or series of connected events arising out of or in connection with this Agreement, any PO placed pursuant to this Agreement, or any other collateral contract, or from or in connection with the Equipment or Software or the use thereof, or the inability to use them either separately or in combination with other equipment or software, or from or in connection with the Services, or from any



other cause, whether caused by negligence, breach of contract, strict liability, breach of warranty, on grounds of failure of essential purpose, or otherwise, shall in no circumstances exceed one million US dollars (US\$1,000,000.00).

6.3 LOCIVA shall be liable for physical damage to Purchaser's property resulting from LOCIVA's negligence up to a maximum aggregate amount of the lesser of three hundred thousand US dollars (US\$300,000.00) or the aggregate Contract Price of the Products and Services in the PO.

6.4 Nothing in this Agreement shall exclude or in any way limit LOCIVA liability for death or personal injury caused by its negligence.

7. SOFTWARE LICENCE.

7.1 LOCIVA shall pass on to Purchaser an MANUFACTURER perpetual, nonexclusive, one-time transferable license to use the Software, only with the Equipment purchased under this Agreement. Software licensed under this Agreement is defined as computer programs contained on any media including: (a) hardwired logic instructions which manipulate data in the central processor and which control input-output operations, error diagnostics, and recovery routine; and (b) instruction sequences in machine-readable code which control call processing, peripheral equipment, and administration and maintenance functions as well as associated documentation used to describe, maintain, and use the programs.

7.2 Purchaser shall: (1) not modify, disassemble or decompile any Software, or reverse engineer any portion of the Software or functioning of the MANUFACTURER's Products, or permit others to do so, without LOCIVA's prior written consent; and (2) not reproduce or copy any Software in whole or in part except for backup and archival purposes or as otherwise permitted in writing by LOCIVA. Information to achieve interoperability of the Software with independently created programs, within the meaning of Article 6 of the Directive on the Legal Protection of Computer Programs, is available from LOCIVA on written request.

8. CONFIDENTIALITY.

8.1 All commercial and technical information, documentation, Software and other proprietary information ("Confidential Information") supplied or made available by one party (the "Supplying Party") to the other ("Receiving Party") under this Agreement, except for that which may be in the public domain, shall, as between the parties hereto, be treated as the confidential and proprietary information of the Supplying Party. The Receiving Party, except as specifically authorised in writing by the Supplying Party, shall: (a) not disclose any Confidential Information received from the Supplying Party to any person, except to its employees on a "need-to-know" basis; (b) not reproduce any Confidential Information received from the Supplying Party, in whole or in part; (c) use any Confidential Information received from the Supplying Party only for operation and maintenance of the Equipment; and (d) indemnify the Supplying Party for any loss or damages resulting from a breach of this Section 8.

8.2 If this Agreement is terminated or cancelled, or if the Receiving Party is found to have breached any of the provisions of Sections 7 or 8, Receiving Party shall immediately return all Confidential Information to the Supplying Party. In any event, the obligations of Sections 7 and 8 will survive termination or cancellation of this Agreement.

8.3 Both parties shall not to publish any press releases or otherwise publicise the existence, or any

of the terms, of this Agreement without the prior written consent of the other party, which consent may be withheld for any reason.

9. EXCUSABLE DELAY.

LOCIVA shall not suffer any liability for non-performance, defective performance, or late performance under this Agreement due to causes beyond its control and without its fault or negligence such as, but not limited to, acts of God, war (including civil war), civil unrest, acts of government, fire, floods, explosions, epidemics, quarantine, restrictions, or reasonably unforeseeable strikes, lock-outs, plant shutdown or material shortages.

10. TERMINATION.

10.1 LOCIVA shall have the right, prior to payment to LOCIVA of the Contract Price, to suspend its performance under this Agreement by written notice to Purchaser and forthwith remove and take possession of any Equipment and Software which has been delivered if Purchaser shall: (a) become insolvent; (b) have a receiver or manager appointed over the whole or any part of its assets or business; (c) make any composition or arrangement with its creditors; (d) take or suffer any similar action in consequence of debt, or an order or resolution is made for its dissolution or liquidation (other than for the purpose of amalgamation or reconstruction); or (e) if Purchaser attempts to resell the Equipment or Software without the consent of LOCIVA.

10.2 In the event of any material breach of this Agreement by either party which shall continue for thirty (30) or more days after written notice of such breach (including a reasonably detailed statement of the nature of such breach) shall have been given to the breaching party by the aggrieved party, the aggrieved party shall be entitled at its option: (a) to terminate this Agreement; or (b) if the aggrieved party is LOCIVA, to suspend performance of all of its obligations under the Agreement for as long as the breach continues; or (c) if the aggrieved party is the Purchaser, to withhold due payments for as long as the breach continues. Notwithstanding anything to the contrary contained in these Terms and Conditions, Purchaser may terminate this Agreement, notwithstanding Section 9 above, if delivery of Equipment has not fully occurred on or before ninety (90) days from the date of this Agreement.

11. PURCHASER RESPONSIBILITIES.

Purchaser shall: (a) ensure that all LOCIVA-designated personnel have the necessary access to Purchaser's premises and the Products to enable it to provide the Services; (b) provide, at no charge to LOCIVA, reasonable working space and facilities including heat, light, ventilation, electric current and outlets for use by LOCIVA's designated personnel and adequate storage space for equipment and materials; (c) provide any information in a timely fashion which LOCIVA reasonably requests from Purchaser and which is required for LOCIVA to provide the Services or other obligations under or in connection with this Agreement; and (e) not perform, or attempt to perform, or cause to be performed any maintenance or repair to the Equipment, other than pursuant to this Agreement, without LOCIVA's prior, written consent. LOCIVA's personnel will comply with site and security regulations as specified by Purchaser.

12. INDEMNITIES

12.1. Each party (an "Indemnifying Party") covenants and agrees that it will indemnify, defend, protect, and hold harmless the other party and its officers, directors, employees, stockholders,

members, managers, agents, representatives, subsidiaries, parents, and affiliates (collectively, the "Indemnified Parties") from and against all obligations, liabilities, fines, damages, losses, costs and other expenses, including, without limitation, any judgments, arbitration awards, amounts paid in settlement, court costs, costs of investigators, fees and expenses of attorneys, accountants, financial advisors and other experts, and other expenses of litigation (collectively, "Damages") incurred as a result of any claims, demands, actions, suits, arbitrations, assessments, adjustments or other proceedings (collectively, "Claims") brought by any third party (including, without limitation, employees of the Indemnifying Party and the Indemnified Parties) arising out of or relating to (a) any breach of representations and warranties of the Indemnifying Party set forth herein; (b) any breach or non-fulfilment of any covenant or obligation on the part of the Indemnifying Party under this Agreement, and (c) any negligent act or intentional misconduct on the part of the Indemnifying Party.

12.2 LOCIVA shall maintain, throughout the term of this Agreement, appropriate insurance policies, including commercial general liability coverage. The commercial liability policy shall include contractual liability. Upon request, LOCIVA shall provide Purchaser with certificates of insurance evidencing LOCIVA's continuing compliance with the preceding sentence. Such policies shall not relieve or limit any of LOCIVA's obligations under this Agreement.

13. MISCELLANEOUS.

13.1 This Agreement shall be construed in accordance with and governed by the laws of the state of Virginia, without regard to its conflicts of law rules. This Agreement is executed in English only, and Purchaser and LOCIVA hereby waive any right which each may have under the laws of any other jurisdiction to have this Agreement executed in any other language.

13.2 All disputes arising out of or in connection with the present contract shall be finally settled under the Rules of Arbitration of the International Chamber of Commerce by one or more arbitrators appointed in accordance with the said Rules. All arbitration proceedings shall be conducted in English and the location of arbitration proceedings shall occur in Virginia.

13.3 All notices, requests, consents and other communications hereunder must be in writing and will be deemed to have been properly given when actually received by LOCIVA's at its address set forth in the Recitals hereto and by Purchaser at its address in the PO.

13.4 All obligations that by their nature survive the expiration, cancellation or termination of this Agreement shall remain in effect after its expiration, cancellation or termination.

13.5 In the performance of its obligations under this Agreement, LOCIVA and Purchaser shall at all times strictly comply with all export laws, regulations, and orders of the United States of America. Purchaser specifically acknowledges that Equipment, Software or technology supplied or licensed by LOCIVA under this Agreement are also subject to U.K. trade sanctions and export control laws and regulations.