



# CERTIFICATE OF COMPLIANCE

**Regulation : FCC Part 2, 90, 90.210**

Applicant	Testing Laboratory
Kenwood Corporation 1-16-2, Hakusan, Midori-ku, Yokohama-shi Kanagawa, 226-8525 Japan Tel.: +81 45 939 6254 Fax.: +81 45 939 7093	Akzo Nobel K. K. Kashima No.1 Test site FCC Registration Number : 934283 1, Sunayama, Kamisu-shi, Ibaraki-ken 314-0255 Japan Tel.: +81 479 40 1097 Fax.: +81 479 46 1788 e-mail: kashima-site@akzoemc.co.jp URL: www.akzoemc.co.jp

<b>Equipment type</b>	UHF DIGITAL REPEATER
<b>Trademark</b>	KENWOOD
<b>Model(s)</b>	TKR-5800
<b>Serial No.</b>	None
<b>FCC ID</b>	K4437144110
<b>Measurement Method</b>	ANSI/TIA/EIA-603B-2002
<b>Deviation from standard(s)</b>	No deviation
<b>Test Result</b>	Complied
<b>Report Number</b>	ANKK-105300
<b>Report issue date</b>	December 01, 2005

This equipment has been shown to be capable of compliance with the applicable standard(s) as indicated in the test report.

I attest to the accuracy of data. All measurements reported herein were performed by me or were made under my supervision and are correct to the best of my knowledge and belief. I assume full responsibility for the completeness of these measurements and vouch for the qualifications of all persons taking them.

This test report shall not be reproduced partially, or in full, without the prior written approval of Akzo Nobel K. K. The results and statements contained in this report pertain only to the equipment evaluated.

Approved by

\_\_\_\_\_  
Takeshi Yamanaka / [Site Manager]

Tested by

\_\_\_\_\_  
Naoki Ikeda

**TABLE OF CONTENTS**

---

	Page
SECTION 1. GENERAL INFORMATION	3
SECTION 2. TEST AND MEASUREMENT DATA	5
SECTION 3. MEASUREMENT RESULT	6
SECTION 4. TEST DATA	
4.1 Carrier Output Power (Conducted)	7
4.2 Unwanted Emissions (Transmitter Conducted)	8
4.3 Field Strength of Spurious Radiation	10
4.4 Emission Masks (Occupied Bandwidth)	14
4.5 Transient Frequency Behavior	17
4.6 Audio Frequency Response / Audio Low Pass Filter (Voice Input)	21
4.7 Modulation Limiting	23
4.8 Frequency Stability (Temperature Variation)	25
4.9 Frequency Stability (Voltage Variation)	27
4.10 Necessary Bandwidth and Emission Bandwidth	29
SECTION 5. VALIDITY OF TEST REPORT	30
SECTION 6. DESCRIPTION OF TEST SITE	30
APPENDIX PHOTOGRAPHS	

---



**SECTION 1.2 GENERAL INFORMATION REQUIRED FOR CERTIFICATION**

**In Accordance with FCC Rules and Regulations, Volume II, Part 2 and 90**

**Sub-part 2.1033**

<b>(c)(1) APPLICANT AND MANUFACTURER INFORMATION</b>	
<b>APPLICANT</b>	
Company	: Kenwood Corporation
Address	: 1-16-2, Hakusan, Midori-ku, Yokohama-shi Kanagawa, 226-8525 Japan
Attenuation	: Tamaki Shimamura Manager, Communications Equipment Division
<b>MANUFACTURER</b>	
Company	: Kenwood Corporation
Address	: 1-16-2, Hakusan, Midori-ku, Yokohama-shi, Kanagawa, 226-8525 Japan

<b>(c)(2) FCC ID</b>	
FCC ID	: K4437144110
Model number	: TKR-5800

<b>(c)(3) INTRUCTION MANUAL(S)</b>	
Instruction manual(s)	: Please refer to attached Exhibits F

<b>(c)(4) TYPE OF EMISSION</b>	
Emission Designation	: 11K0F3E / 6K00F1E / 6K00F1D

<b>(c)(5) FREQUENCY RANGE</b>	
Frequency Range	: 450 to 483 MHz

<b>(c)(6) POWER RATING</b>	
Output Power	: 0.5 to 5 W
Type	: Variable

<b>(c)(7) MAXIMUM POWER RATING</b>	
Output Power	: 5 W

<b>OTHER INFORMATION</b>	
Number of Channel	: 30
Channel Spacing	: 12.5 kHz / 6.25 kHz
Antenna Impedance	: 50 Ω Norminal

<b>Note</b>	
a. DC Power Supply cable is supplied together with EUT by the applicant.	
b. One core of DC Power Supply cable is supplied together with EUT by the applicant.	

**SECTION 2. TEST AND MEASUREMENT DATA**

All test and measurements indicated in this document were performed in accordance with the Code of Federal Regulations Title 47 Part 2, Sub-part J and Industry Canada as the following individual parts:

FCC RULE	TEST ITEM	Tested
Part 21	Domestic Public Fixed radio Services	N.A.
Part 22	Non Cellular	N.A.
Part 22	Public Mobile Services	N.A.
Part 22	Subpart H - Cellular Radiotelephone Service	N.A.
Part 22	Alternative technologies and auxiliary service	N.A.
Part 23	International Fixed Public Radiocommunication service	N.A.
Part 24	Personal Communications Services	N.A.
Part 74	Subpart H - Low Power Auxiliary Stations	N.A.
Part 80	Stations in the Maritime Services	N.A.
Part 80	Subpart E - general Technical Standards	N.A.
Part 80	Subpart F - Equipment Authorization for Compulsory Ships	N.A.
Part 80	Subpart K - Private Coast Stations and Marine Utility Stations	N.A.
Part 80	Subpart S - Compulsory radiotelephone Installations for Small Passenger Boats	N.A.
Part 80	Subpart T - Radiotelephone Installation Required for Vessels on the Great Lakes	N.A.
Part 80	Subpart U - Radiotelephone Installations Required by the Bridge-to-Bridge Act	N.A.
Part 80	Subpart V - Emergency Position Indicating Radiobeacons (EPIRB'S)	N.A.
Part 80	Subpart W - Global Maritime Distress and Safety System (GMDSS)	N.A.
Part 80	Subpart X - Voluntary Radio Installations	N.A.
Part 87	Aviation Services	N.A.
<b>Part 90</b>	<b>Private Land Mobile radio Services</b>	<b>YES</b>
Part 94	Private Operational - Fixed Microwave Service	N.A.
Part 95	Subpart A - General Mobile radio Service	N.A.
Part 95	Subpart C - Radio Control (R/C) radio Service	N.A.
Part 95	Subpart D - Citizens Band (CB) Radio Service	N.A.
Part 95	Subpart E -Family radio Service	N.A.
Part 95	Subpart F -Interactive Video and Data Service (IVDS)	N.A.
Part 97	Amateur Radio Service	N.A.
Part 101	Fixed Microwave Service	N.A.

IC RULE	TEST ITEM	Tested
RSS-119	Land Mobile and Fixed Radio Transmitters and Receivers	N.A.

**SECTION 3. MEASUREMENT RESULT**

FCC Part2	Part90	TEST ITEM	RESULTS
2.1046 (a)	-	Carrier Output Power (Conducted)	PASS
2.1051	90.210	Unwanted Emissions (Transmitter Conducted)	PASS
2.1053 (a)	90.210	Field Strength of Spurious Radiation	PASS
2.1049 (c) (1)	90.210	Emission Masks (Occupied Bandwidth)	PASS
-	90.214	Transient Frequency Behavior	PASS
2.1047 (a)	90.242 (b) (8)	Audio Low Pass Filter (Voice Input)	PASS
2.1047 (a)	-	Audio Frequency Response	PASS
2.1047 (b)	-	Modulation Limiting	PASS
2.1055 (a) (1)	90.213 (a)	Frequency Stability (Temperature Variation)	PASS
2.1055 (d) (1)	90.213 (a)	Frequency Stability (Voltage Variation)	PASS

**Limitation on Results**

The test result of this report is effective equipment under test itself and under the test configuration described on the report.

This test report does not assure that whether the test result taken in other testing laboratory is compatible or reproducible to the test result on this report or not.

**SECTION 4. TEST DATA**

**4.1 Carrier Output Power (Conducted)**

REGULATIONS	: 47 CFR 2.1046 (a)
TEST METHOD/GUIDE	: ANSI/TIA/EIA-603B-2002, section 2.2.1.2

**TEST PROCEDURE**

- 1 The EUT and test equipment were set up as shown on the following page.
  - 2 The EUT was conducted to a resistive coaxial attenuator of normal load impedance.
- RF Power (dBm) = Power Meter reading (dBm) + Attenuator Loss (dB) + Cable Loss (dB)  
 RF Power (W) = 10<sup>(RF Power (dBm)/10)</sup>/1000

**TEST EQUIPMENTS**

No.	Equipment	Manufacture	Model No.	Serial No.	Cal Exp.
1	Power Meter	Hewlett Packard	E4418B	GB38410265	Sep-06
2	Power Sensor	Hewlett Packard	8482A	2607A11551	Jan-06
3	Attenuator (20dB)	Weinschel	40-20-34	AA5701	Jul-06
4	Attenuator (30dB)	Weinschel	WA-29-30-34	8923	Jul-06
5	50Ω Termination	TME	CT-01	None	Oct-06
6	DC Power Supply	DAIWA	PS-3020	None	None
7	Digital Multi Meter	Sanwa	CD721	3215593	Apr-06

**MEASUREMENT EQUIPMENT CONFIGURATION**

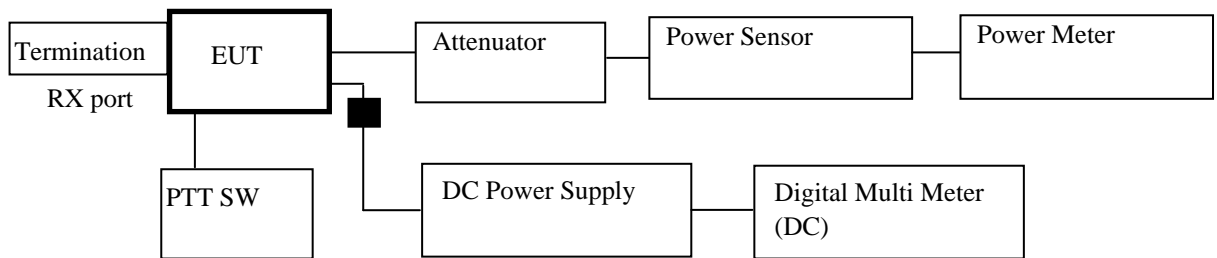

■ : Ferrite core

**UNCERTAINTY**

Measurement uncertainty is +/- 0.5dB (k = 2)

**TEST RESULTS**

Measured for the worst case

No.	Frequency (MHz)	Setting	RF Power (W)
1	450.025	Low High Power	5
2	466.525	Mid High Power	5
3	482.975	High High Power	5
4	450.025	Low Low Power	0.5
5	466.525	Mid Low Power	0.5
6	482.975	High Low Power	0.5

**4.2 Unwanted Emissions (Transmitter Conducted)**

REGULATIONS	: 47 CFR 2.1051, 90.210
TEST METHOD/GUIDE	: ANSI/TIA/EIA-603B-2002, section 2.2.13.2

**TEST PROCEDURE**

- 1 The EUT and test equipment were set up as shown on the following page.
- 2 Modulate the transmitter with a 2.5 kHz sine wave at an input Level of 16 dB greater than that necessary to produce 50 % of rated system deviation.
- 3 Adjust the spectrum analyzer for the following setting:
  - a) Resolution Bandwidth : 10 kHz (< 1 GHz), 1 MHz (> 1 GHz).
  - b) Video Bandwidth : 30 kHz (< 1 GHz), 3 MHz (> 1 GHz).
  - c) Sweep Speed : 50 msec.
  - d) Detector mode : Average
- 4 The emissions were measured for the worst case as follows:
  - a) : within a band of frequencies defined by the carrier frequency plus and minus one channel.
  - b) : from the lowest frequency generated in the EUT and to at least the 10th harmonic of the carrier frequency, or 40 GHz, whichever is lower.

**TEST EQUIPMENTS**

No.	Equipment	Manufacture	Model No.	Serial No.	Cal Exp.
1	Audio Generator	ANRITSU	MG443B	1004468	Jun-06
2	Attenuator (20dB)	Weinschel	40-20-34	AA5701	Jul-06
3	Attenuator (30dB)	Weinschel	WA-29-30-34	8923	Jul-06
4	Modulation Analyzer	Hewlett Packard	8901B	3403A04852	Mar-06
5	Signal Generator	Hewlett Packard	8567B	3247U03266	Feb-06
6	Spectrum Analyzer	Agilent	E7403A	MY42000062	Jul-06
7	50Ω Termination	TME	CT-01	None	Oct-06
8	DC Power Supply	DAIWA	PS-3020	None	None
9	Digital Multi Meter	Sanwa	CD721	3215593	Apr-06

**MEASUREMENT EQUIPMENT CONFIGURATION**

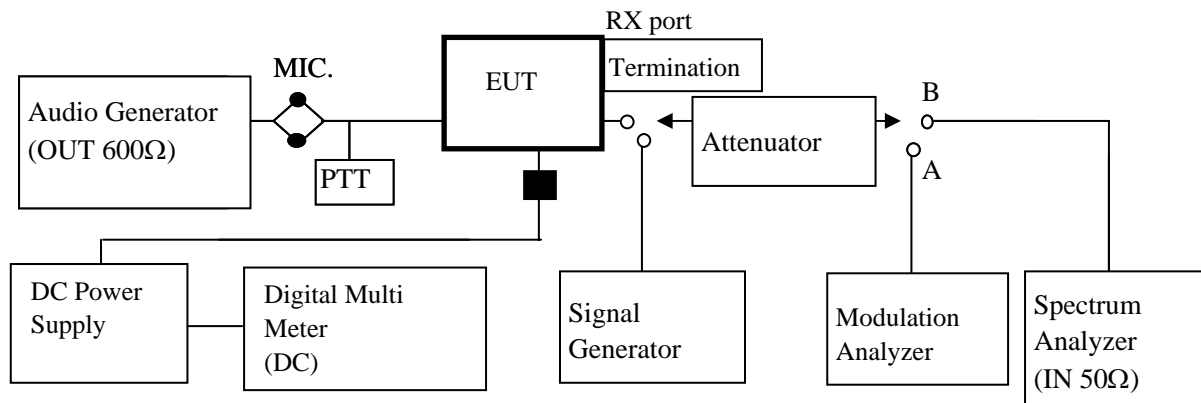

■ : Ferrite core

**UNCERTAINTY**

Measurement uncertainty is +/- 1.2 dB (k = 2)



**TEST RESULTS**

Measured for the worst case

State : High Power / 12.5 kHz channel bandwidth

No.	Frequency (MHz)		Correct Level (dBm)	Emission Level (dBc)	Limit (dBc)	Margin (dB)
1	900.05	Low	-34.80	-71.79	-62.0	9.8
2	933.05	Mid	-37.51	-74.50	-62.0	12.5
3	965.95	High	-37.50	-74.49	-62.0	12.5

There is the margin of 20dB over except for the above points.

State : Low Power / 12.5 kHz channel bandwidth

No.	Frequency (MHz)		Correct Level (dBm)	Emission Level (dBc)	Limit (dBc)	Margin (dB)
1	900.05	Low	-	-	-52.0	-
2	933.05	Mid	-	-	-52.0	-
3	965.95	High	-	-	-52.0	-

There is the margin of 20dB over except for the above points.

Mask E Limit (dBc) =  $-(55+10\text{Log}(P))$

Correct Level (dBm) = Substitute SG Level (dBm)

Emission Level (dBc) = Correct Level (dBm) -  $10\text{Log}(P*1000)$

P = Carrier Level (W)

" - " = Measurement Limit

**4.3 Field Strength of Spurious Radiation**

REGULATIONS	: 47 CFR 2.1053 (a), 90.210
TEST METHOD/GUIDE	: ANSI/TIA/EIA-603B-2002, section 2.2.12.2

**TEST PROCEDURE**

- 1 The EUT and test equipment were set up as shown on the following page.
- 2 Adjust the spectrum analyzer for the following setting:
  - a) Resolution Bandwidth : 10 kHz (< 1 GHz), 1 MHz (> 1 GHz).
  - b) Video Bandwidth : 300 kHz (< 1 GHz), 3 MHz (> 1 GHz).
  - c) Sweep Speed : 50ms.
  - d) Detector mode : Positive Peak
- 3 The transmitter was placed on a wooden turntable, and it was transmitting into non-radiating load which was also placed on the turntable.
- 4 The measurement antenna was placed at a distance of 3 meters from the EUT.
 

During the tests, the antenna height and polarization as well as EUT azimuth were varied in order to identify the maximum level of emissions from the EUT.

The test was performed by placing the EUT on 3-orthogonal axis.
- 5 The frequency range up to tenth harmonic of the fundamental frequency was investigated.
- 6 Remove the EUT and replace it with substitution antenna. A signal generator was connected to the substitution antenna by a non-radiating cable.
 

The absolute levels of the spurious emissions were measured by the substitution.
- 7 Spurious emissions in dB = 10 Log (TX power in Watts/0.001) – the absolute level
- 8 Spurious attenuation 6.25 kHz channel bandwidth limit in dB = 55 + 10 Log10 (power out in Watts)
- 9 Spurious attenuation 12.5 kHz channel bandwidth limit in dB = 50 + 10 Log10 (power out in Watts)

**TEST EQUIPMENTS**

No.	Equipment	Manufacture	Model No.	Serial No.	Cal Exp.
1	Dipole Antenna(TX)	Schwarzbeck	UHA9105	None	Mar-06
2	D.R.G Antenna(TX)	Schwarzbeck	BBHA 9120 D	457	Apr-06
3	Tri-log Antenna(RX)	Schwarzbeck	VULB9167WP	106	Mar-06
4	D.R.G Antenna(RX)	Schwarzbeck	3115	9612-5044	Jun-06
5	Pre-Amplifier	Hewlett Packard	83051A	3332A00329	Jun-06
6	Step Attenuator	Hewlett Packard	8494B	2726A14513	Nov-06
7	Attenuator(6dB)	ANRITSU	MP721B	M57593	Nov-06
8	Attenuator(3dB)	Narda	4768-3	79	Sep-06
9	Spectrum Analyzer	Hewlett Packard	8564E	3643A00665	Aug-06
10	Signal Generator	Hewlett Packard	8657B	3247U03266	Feb-06
11	Signal Generator	Hewlett Packard	8672A	2449A04106	Jul-06
12	50Ω Termination	TME	CT-01	None	Oct-06
13	Dummy Load	TME	CT-150NP	1138693	Jul-06
14	DC Power Supply	Daiwa	PS-3020	None	None
15	Digital Mlti Meter	Sanwa	CD721	3215593	Apr-06

### MEASUREMENT EQUIPMENT CONFIGURATION

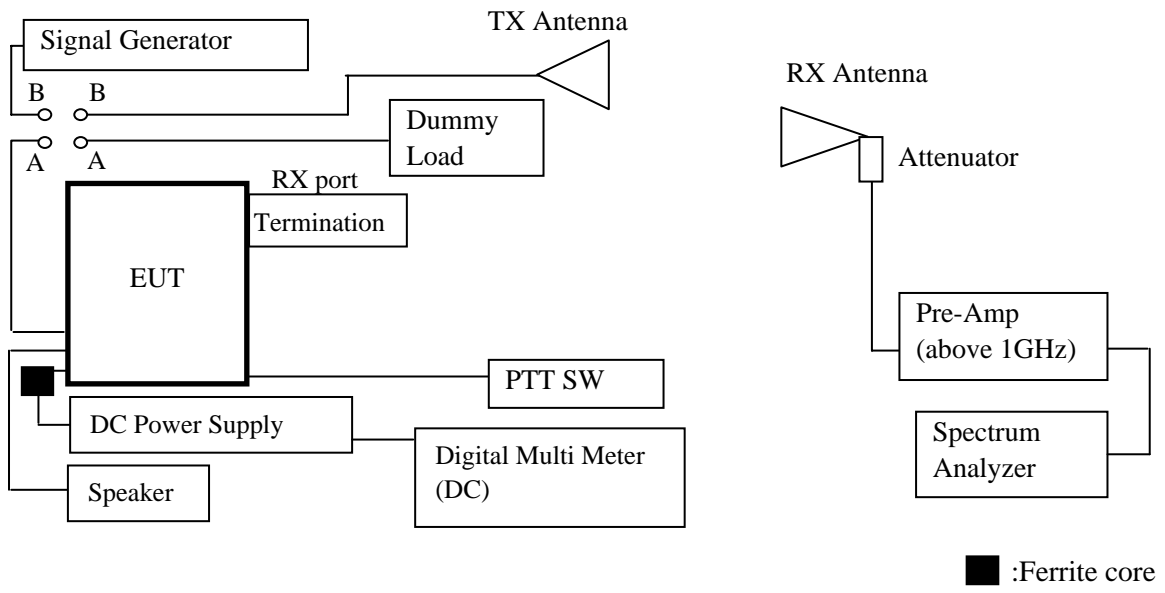

### UNCERTAINTY

Measurement uncertainty is +/- 4.2dB (k = 2)

**TEST RESULTS**

Measured for the worst case

State : High Power / 12.5 kHz channel bandwidth / 450.025 MHz

No	Frequency (MHz)	Pol	Reading Level (dBm)	SG Out Level (dBm)	Cable Loss (dB)	Antenna Gain (dBi)	Correct Level (dBm)	Emission Level (dBc)	Limit Level (dBc)	Margin (dB)
1	900.05	Hor.	-83.85	-46.00	2.28	2.15	-46.1	-83.1	-62.0	21.1
		Ver.	-84.00	-48.00	2.28	2.15	-48.1	-85.1	-62.0	23.1
2	1350.08	Hor.	-61.00	-57.80	1.72	7.89	-51.6	-88.6	-62.0	26.6
		Ver.	-61.42	-57.30	1.72	7.89	-51.1	-88.1	-62.0	26.1
3	1800.10	Hor.	-62.25	-61.70	2.00	10.32	-53.4	-90.4	-62.0	28.4
		Ver.	-63.00	-56.90	2.00	10.32	-48.6	-85.6	-62.0	23.6
4	2250.13	Hor.	-	-	2.25	10.50	-	-	-	-
		Ver.	-61.25	-53.10	2.25	10.50	-44.8	-81.8	-62.0	19.8
5	2700.15	Hor.	-64.40	-58.50	2.45	11.00	-50.0	-86.9	-62.0	25.0
		Ver.	-63.00	-54.75	2.45	11.00	-46.2	-83.2	-62.0	21.2
6	3150.18	Hor.	-66.00	-64.50	2.70	11.89	-55.3	-92.3	-62.0	30.3
		Ver.	-	-	2.70	11.89	-	-	-	-
7	3600.20	Hor.	-62.10	-51.76	2.92	12.60	-42.1	-79.1	-62.0	17.1
		Ver.	-54.33	-42.00	2.92	12.60	-32.3	-69.3	-62.0	7.3
8	4050.23	Hor.	-68.00	-58.25	3.14	12.57	-48.8	-85.8	-62.0	23.8
		Ver.	-63.20	-55.50	3.14	12.57	-46.1	-83.1	-62.0	21.1
9	4500.25	Hor.	-70.00	-60.00	3.37	12.67	-50.7	-87.7	-62.0	25.7
		Ver.	-63.25	-51.20	3.37	12.67	-41.9	-78.9	-62.0	16.9

There is the margin of 20dB over except for the above points.

Mask E Limit (dBc) = -(55+10Log(P))

Correct Level (dBm) = Substitute SG Level (dBm) + ANT Gain (dBi) - Cable Loss (dB)

Emission Level (dBc) = Correct Level (dBm) - 10Log(P\*1000)

P = Carrier Level (W)

" - " = Measurement Limit

State : Low Power / 12.5 kHz channel bandwidth / 482.975 MHz

No	Frequency (MHz)	Pol	Reading Level (dBm)	SG Out Level (dBm)	Cable Loss (dB)	Antenna Gain (dBi)	Correct Level (dBm)	Emission Level (dBc)	Limit Level (dBc)	Margin (dB)
1	965.95	Hor.	-	-	2.38	2.15	-	-	-	-
		Ver.	-88.00	-50.00	2.38	2.15	-50.2	-77.2	-52.0	25.2
2	1448.93	Hor.	-62.40	-58.70	1.79	8.38	-52.1	-79.1	-52.0	27.1
		Ver.	-61.20	-57.20	1.79	8.38	-50.6	-77.6	-52.0	25.6
3	1931.90	Hor.	-58.40	-51.40	2.08	10.34	-43.1	-70.1	-52.0	18.1
		Ver.	-55.00	-45.90	2.08	10.34	-37.6	-64.6	-52.0	12.6
4	2414.88	Hor.	-56.50	-48.00	2.33	10.56	-39.8	-66.8	-52.0	14.8
		Ver.	-50.08	-42.00	2.33	10.56	-33.8	-60.8	-52.0	8.8
5	2897.85	Hor.	-67.50	-66.80	2.56	11.37	-58.0	-85.0	-52.0	33.0
		Ver.	-66.30	-56.40	2.56	11.37	-47.6	-74.6	-52.0	22.6
6	3380.83	Hor.	-	-	2.78	12.36	-	-	-	-
		Ver.	-68.10	-67.40	2.78	12.36	-57.8	-84.8	-52.0	32.8
7	3863.80	Hor.	-	-	3.03	12.58	-	-	-	-
		Ver.	-68.10	-57.00	3.03	12.58	-47.5	-74.4	-52.0	22.5
8	4346.78	Hor.	-68.70	-57.90	3.33	12.65	-48.6	-75.6	-52.0	23.6
		Ver.	-65.60	-64.80	3.33	12.65	-55.5	-82.5	-52.0	30.5
9	4829.75	Hor.	-	-	3.76	12.63	-	-	-	-
		Ver.	-	-	3.76	12.63	-	-	-	-

There is the margin of 20dB over except for the above points.

Mask E Limit (dBc) = -(55+10Log(P))

Correct Level (dBm) = Substitute SG Level (dBm) + ANT Gain (dBi) - Cable Loss (dB)

Emission Level (dBc) = Correct Level (dBm) - 10Log(P\*1000)

P = Carrier Level (W)

" - " = Measurement Limit

**4.4 Emission Masks (Occupied Bandwidth)**

REGULATIONS	: 47 CFR 2.1049 (c) (1), 22.359, 357 (a) (1) , 74.1236 , 90.210
TEST METHOD/GUIDE	: ANSI/TIA/EIA-603B-2002, section 2.2.11.2

**TEST PROCEDURE**

- 1 The EUT and test equipment were set up as shown on the following page.
- 2 For EUT supporting audio modulation, the audio signal generator was adjusted to the frequency of maximum response and with output level set for +/- 2.5 kHz or +/- 1.80 kHz deviation (or 50 % modulation).
- 3 With level constant, the signal level was increased 16 dB.  
For EUT supporting digital modulation, the digital modulation mode was operated to its maximum extent.
- 4 Adjust the spectrum analyzer for the following setting:
  - a) Resolution Bandwidth : 100 Hz (Nonmodulation and 12.5 kHz channel and 6.25 kHz channel bandwidth).
  - b) Video Bandwidth : 100 Hz (Nonmodulation and 12.5 kHz channel and 6.25 kHz channel bandwidth).
  - c) Sweep Speed : 8 sec.
  - d) Sampling Time : 10 times
- 5 The occupied Bandwidth was measured with the Spectrum Analyzer controls set as shown on the test results.

**TEST EQUIPMENTS**

No.	Equipment	Manufacture	Model No.	Serial No.	Cal Exp.
1	Audio Generator	ANRITSU	MG443B	1004468	Jun-06
2	Attenuator (20dB)	Weinschel	40-20-34	AA5701	Jul-06
3	Attenuator (30dB)	Weinschel	WA-29-30-34	8923	Jul-06
4	Modulation Analyzer	HP	8901B	3403A04852	Mar-06
5	Spectrum Analyzer	Agilent	E7401A	US39440256	Aug-06
6	50Ω Termination	TME	CT-01	None	Oct-06
7	DC Power Supply	DAIWA	PS-3020	None	None
8	Digital Multi Meter	Sanwa	CD721	3215593	Apr-06

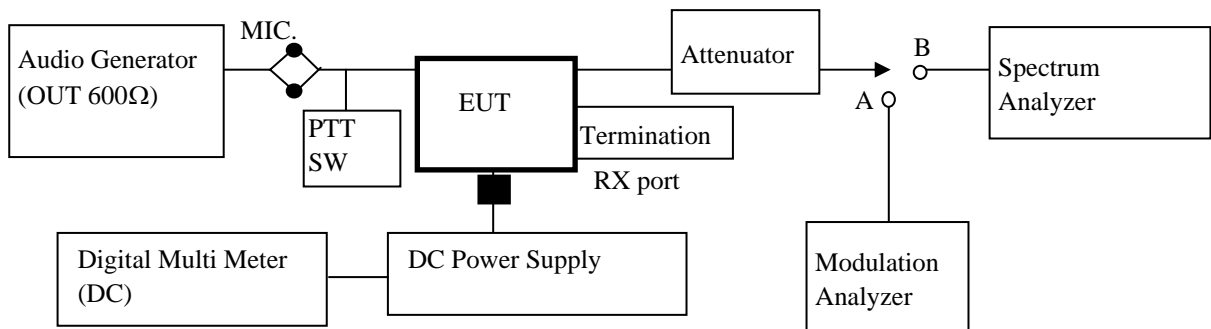

■ : Ferrite core

**UNCERTAINTY**

Measurement uncertainty is +/- 1.2dB (k = 2)

### TEST RESULTS

Measured for the worst case

State : High Power / None Modulation / 450.025 MHz

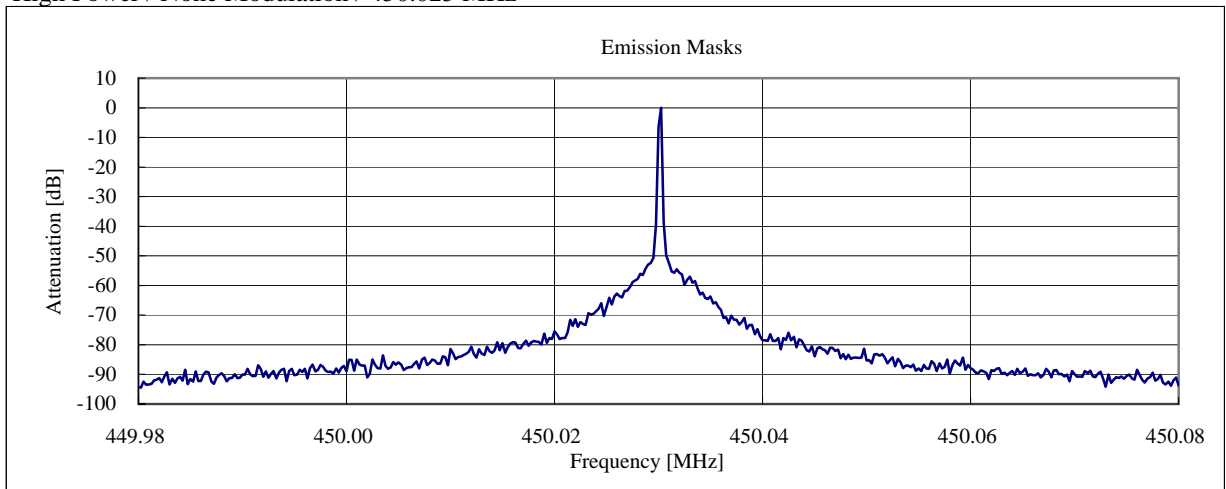

State : High Power / 12.5 kHz channel bandwidth:FM / 450.025 MHz

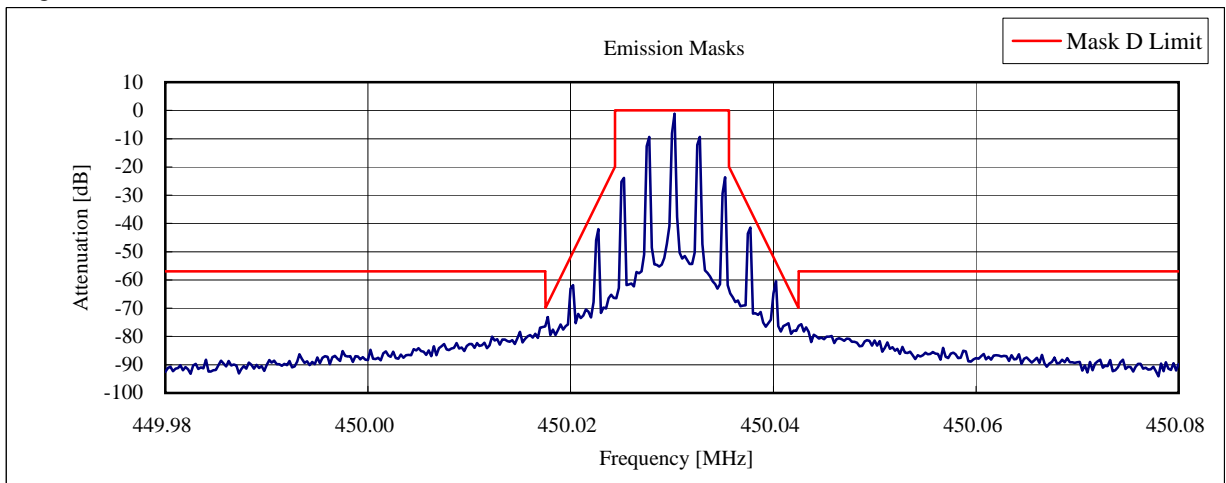

State : High Power / 6.25 kHz channel bandwidth:4 Level FSK / 450.025 MHz

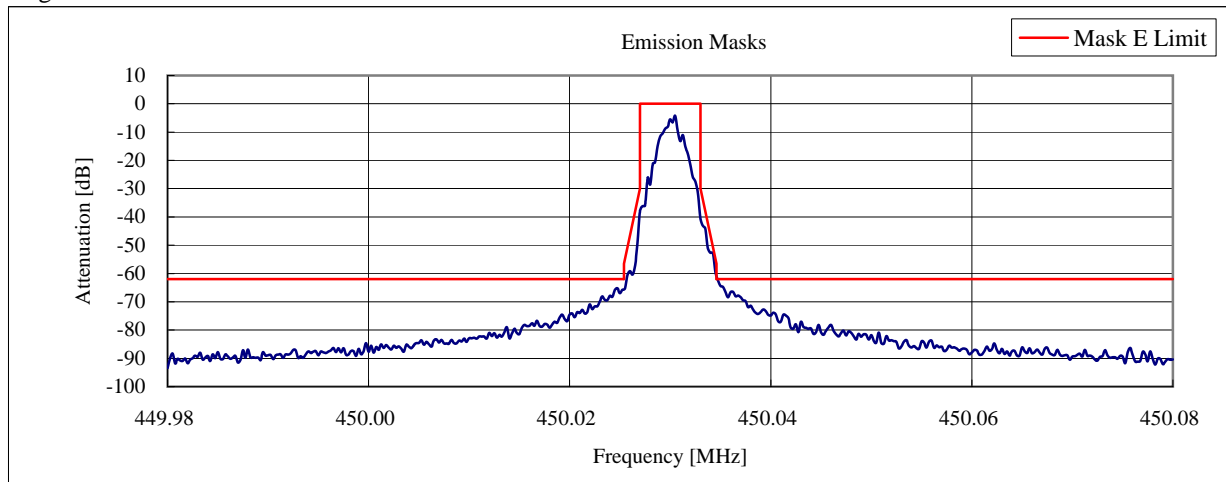

State : Low Power / None Modulation / 482.975 MHz

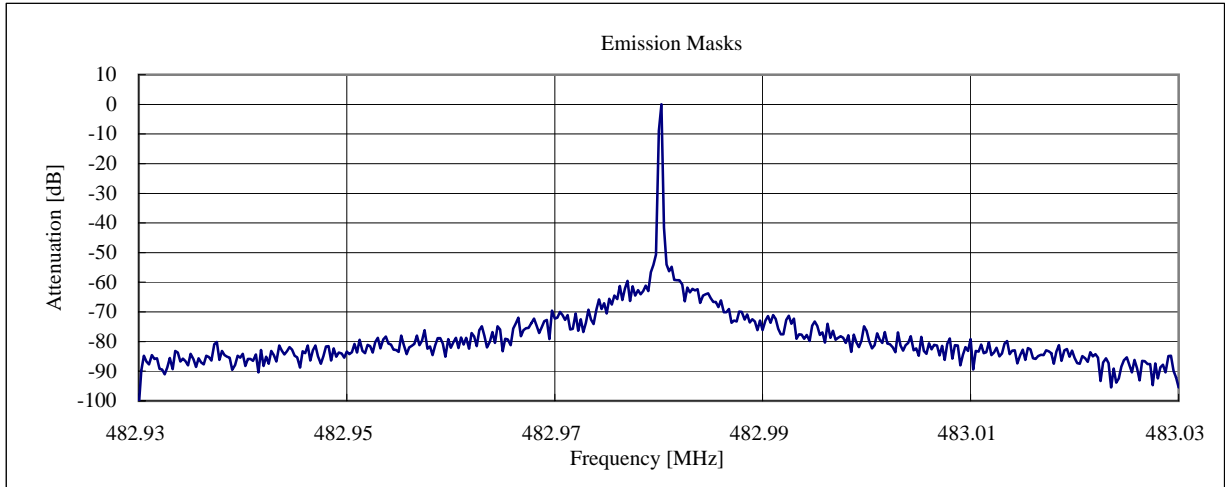

State : Low Power / 12.5 kHz channel bandwidth:FM / 482.975 MHz

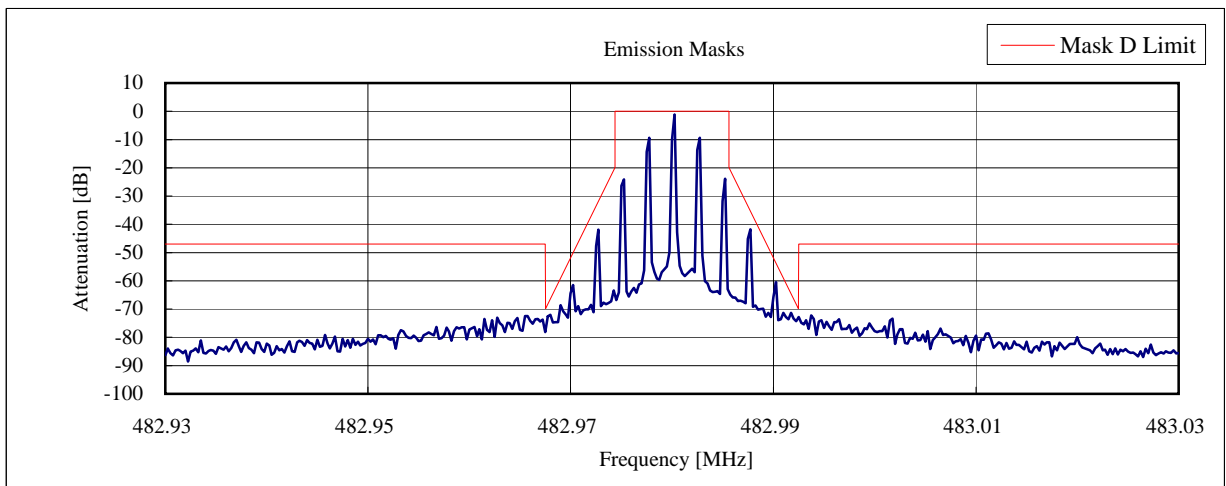

State : Low Power / 6.25 kHz channel bandwidth:4 Level FSK / 482.975 MHz

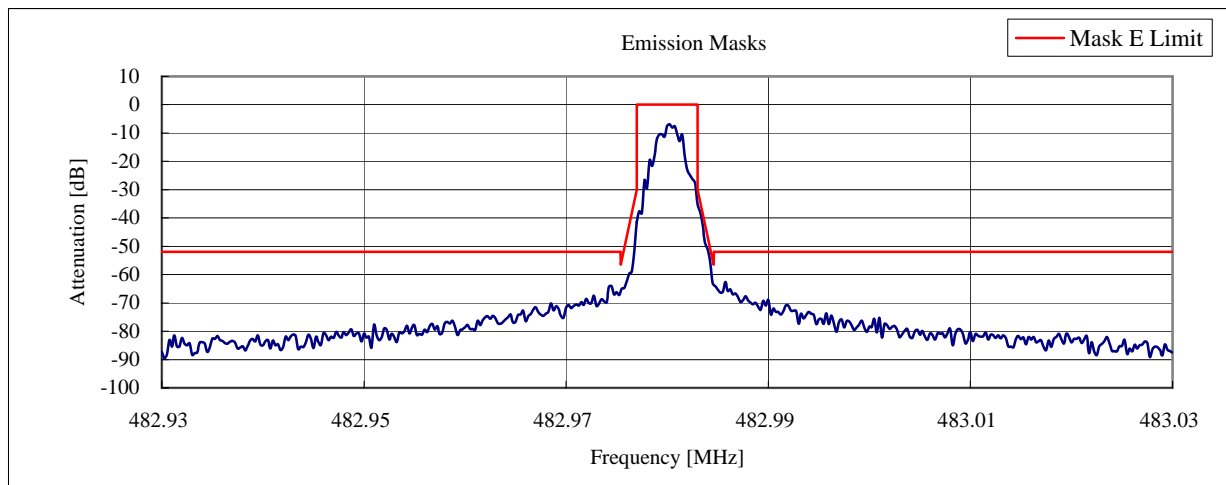



**4.5 Transient Frequency Behavior**

REGULATIONS	: 47 CFR 90.214
TEST METHOD/GUIDE	: ANSI/TIA/EIA-603B-2002, section 2.2.19.3

**TEST PROCEDURE**

- 1 The EUT and test equipment were set up as shown on the following page.
- 2 The transmitter was turned on.
- 3 Sufficient attenuation was provided so that the transmitter carrier level measured at the output of the combiner was 40 dB below the maximum input level of the test receiver.  
This level was recorded as step f.
- 4 The transmitter was turned off.
- 5 An RF signal generator (1) modulated with a 1 kHz tone at either 12.5 kHz or 6.25 kHz deviation, and set to the same frequency as the assigned transmitter frequency, (2) was adjusted to a level -20 dB below the level recorded for step f, as measured at the output of the combiner.  
This level was then fixed for the remainder of the test and is recorded at step h.
- 6 The oscilloscope was setup using TIA/EIA-603B-2002 steps j and k as a guide, and to 10 msec./div.
- 7 The transmitter was turned on, and the level of the carrier at the output of the combiner was recorded as step l.
- 8 The carrier on-time as referenced in TIA/EIA-603B-2002 steps m, n, and o was captured and plotted.
- 9 The carrier off-time as referenced in TIA/EIA-603B-2002 steps p, q, r, and s was captured and plotted.

**TEST EQUIPMENTS**

No.	Equipment	Manufacture	Model No.	Serial No.	Cal Exp.
1	Signal Generator	Hewlett Packard	8657B	3247U03266	Feb-06
2	Oscilloscope	IWATSU-LeCroy	LT342	00922	Jul-06
3	Power Meter	Hewlett Packard	E4418B	GB38410265	Sep-06
4	Power Sensor	Hewlett Packard	8482A	2607A11551	Jan-06
5	Attenuator (20dB)	Weinschel	40-20-34	AA5701	Jul-06
6	Modulation Analyzer	Hewlett Packard	8901B	3403A04852	Mar-06
7	Combiner(1)	ANRITSU	Z-164A	M89549	Jul-06
8	Combiner(2)	ANRITSU	Z-164A	M89249	Jul-06
9	Attenuator (3dB)	TMA	CFA-20NPJ-3	679701	Jul-06
10	50Ω Termination	TME	CT-01	None	Oct-06
11	DC Power Supply	DAIWA	PS-3020	None	None
12	Digital Multi Meter	Sanwa	CD721	3040939	Apr-06

**MEASUREMENT EQUIPMENT CONFIGURATION**

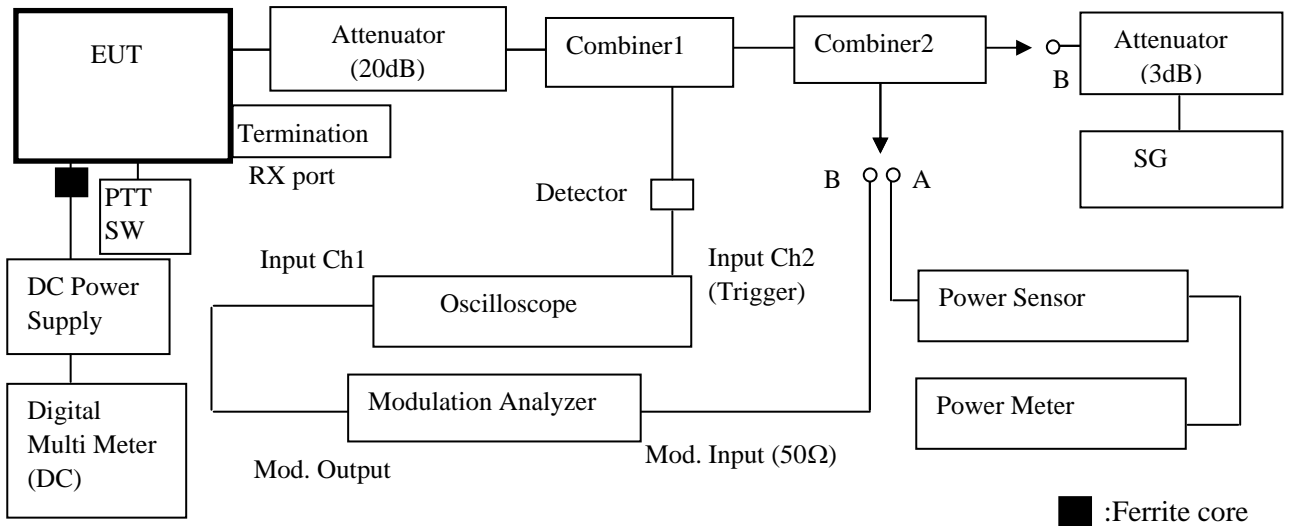

**UNCERTAINTY**

Measurement uncertainty is +/- 1.3dB (k = 2)

### TEST RESULTS

Measured for the worst case

State : High Power / 12.5 kHz channel bandwidth:FM / 466.525 MHz / PTT:OFF -ON

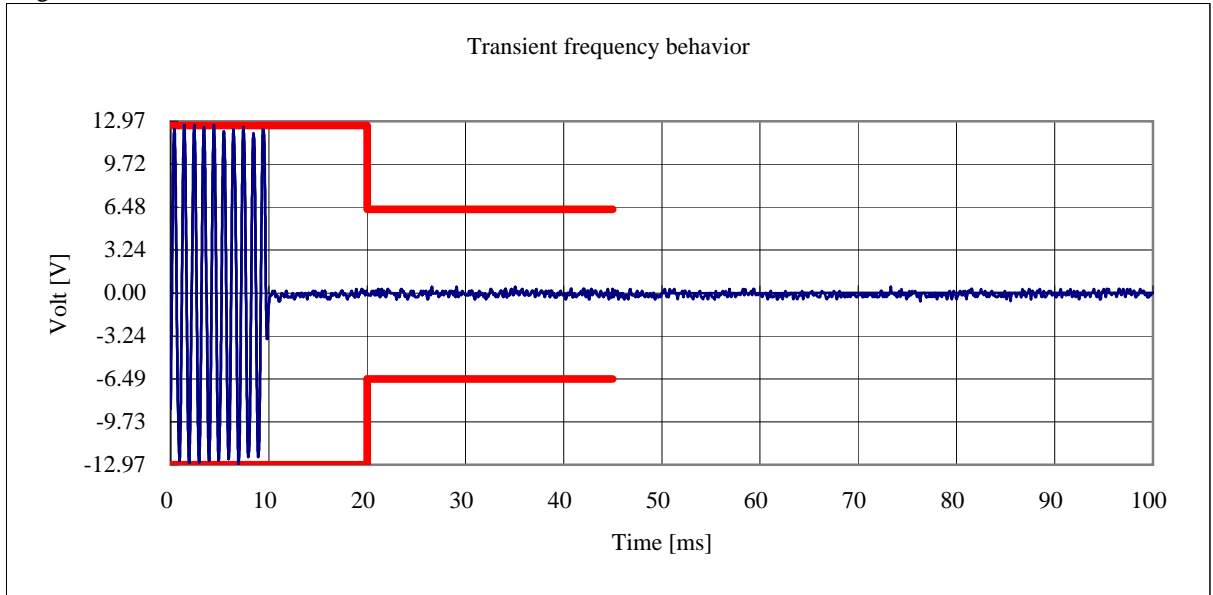

State : High Power / 12.5 kHz channel bandwidth:FM / 466.525 MHz / PTT:ON -OFF

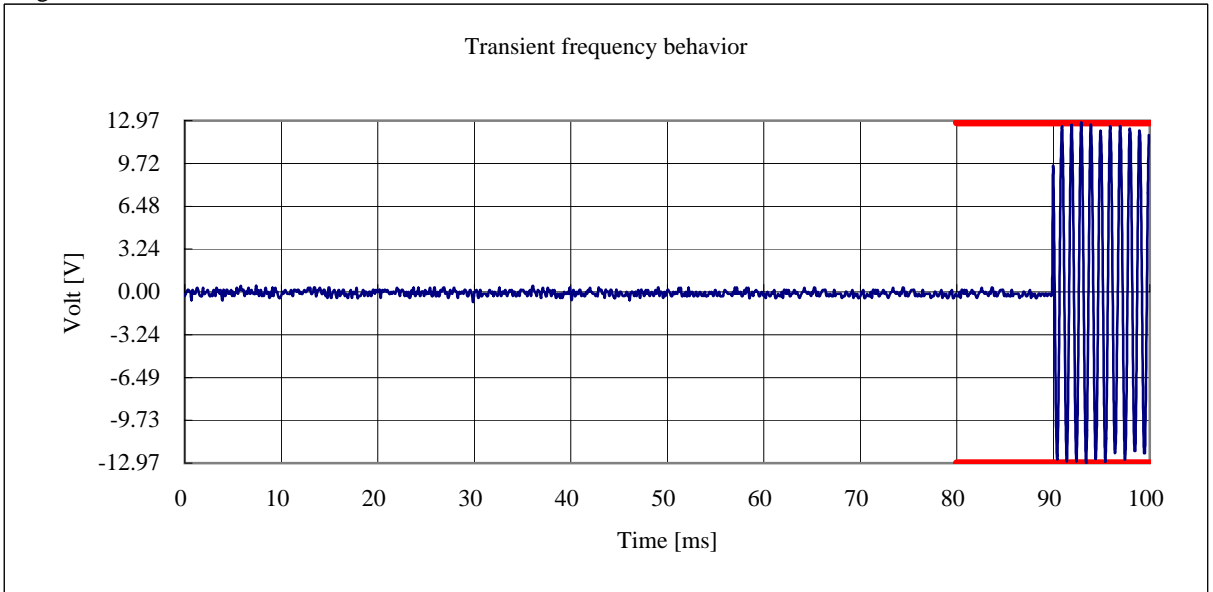

State : High Power / 6.25 kHz channel bandwidth:4Level FSK / 466.525 MHz / PTT:OFF -ON

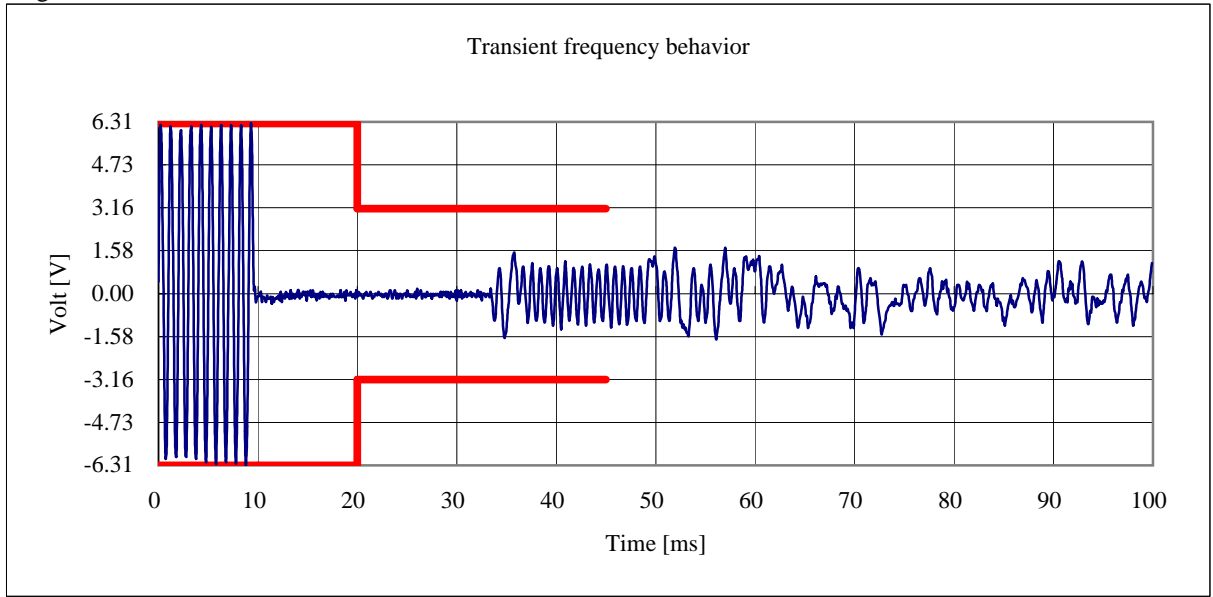

PTT: ON-OFF

State : High Power / 6.25 kHz channel bandwidth:4Level FSK / 466.525 MHz / PTT:ON -OFF

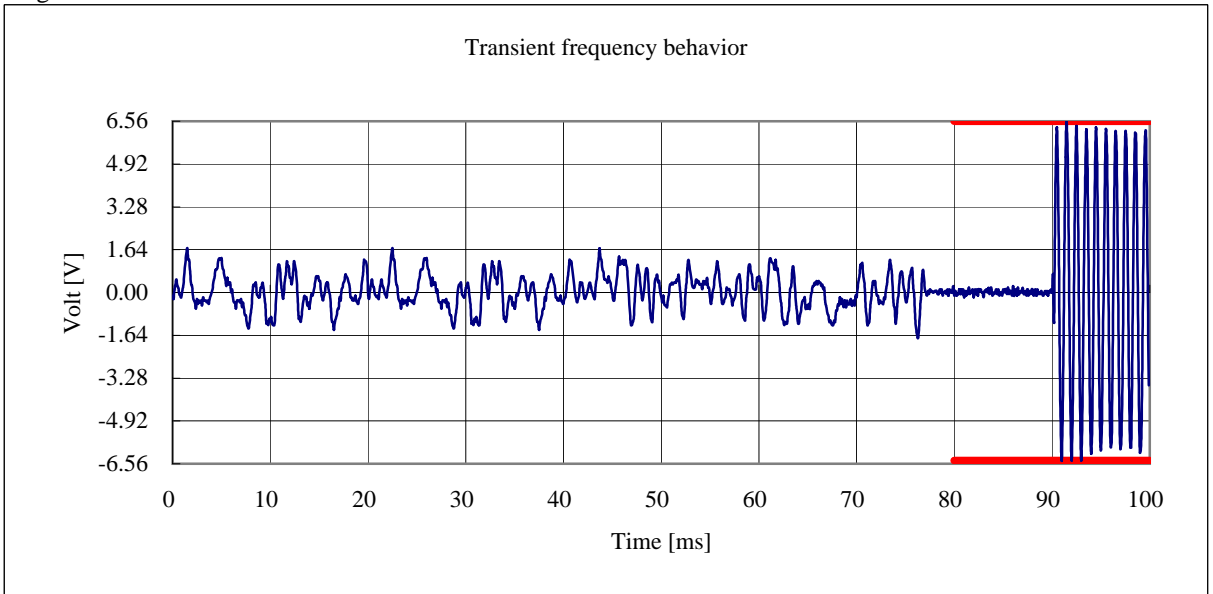

**4.6 Audio Frequency Response / Audio Low Pass Filter (Voice Input)**

REGULATIONS	: 47 CFR 2.1047 (a)
TEST METHOD/GUIDE	: ANSI/TIA/EIA-603B-2002, section 2.2.6.2.2, 3.2.6.2

**TEST PROCEDURE**

- 1 The EUT and test equipment were set up as shown on the following page.
- 2 Adjust the Modulation Analyzer for the following setting:
  - a) High-pass filter : 50 Hz
  - b) Low-pass filter : 15 kHz
  - c) Detector : positive peak
  - d) Function : FM
- 3 The audio signal input was adjusted to obtain 20 % modulation at 1 kHz, and this point was taken as the 0 dB reference level.
- 4 With input levels held constant and below limiting at all frequencies, the audio signal generator was varied from 300 Hz to 5 kHz.
- 5 The response in dB relative to 1 kHz was then measured, using the Modulation Analyzer.

**TEST EQUIPMENTS**

No.	Equipment	Manufacture	Model No.	Serial No.	Cal Exp.
1	Audio Generator	ANRITSU	MG443B	1004468	Jun-06
2	Attenuator (20dB)	Weinschel	40-20-34	AA5701	Jul-06
3	Attenuator (30dB)	Weinschel	WA-29-30-34	8923	Jul-06
4	50Ω Termination	TME	CT-01	None	Oct-06
5	Modulation Analyzer	HP	8901B	3403A04852	Mar-06
6	Audio Analyzer	HP	8903B	2948A07326	Mar-06
7	DC Power Supply	DAIWA	PS-3020	None	None
8	Digital Multi Meter	Sanwa	CD721	3215593	Apr-06

**MEASUREMENT EQUIPMENT CONFIGURATION**

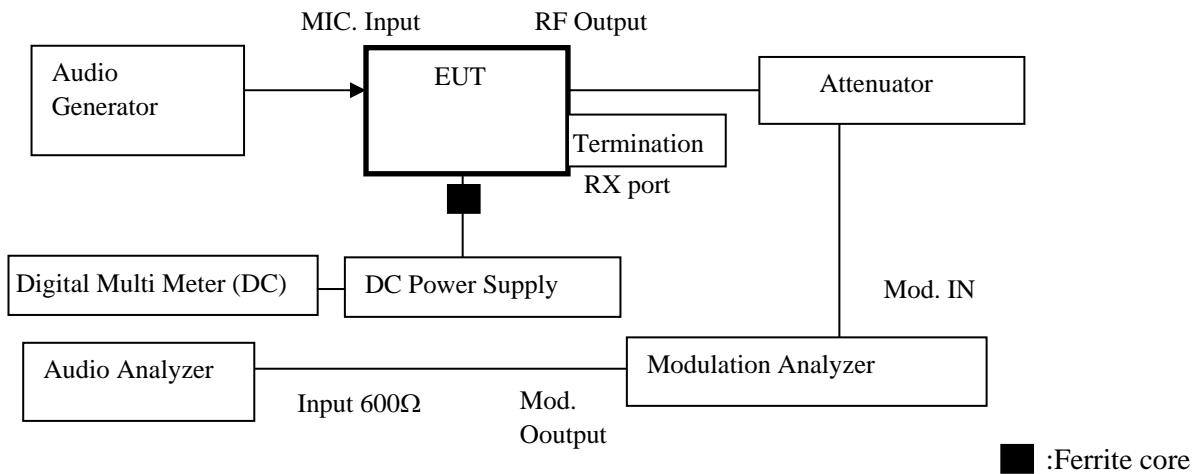

**UNCERTAINTY**

Measurement uncertainty is +/- 1.2dB (k = 2)

### TEST RESULTS

Measured for the worst case

State : High Power / 12.5 kHz channel bandwidth / 450.025 MHz

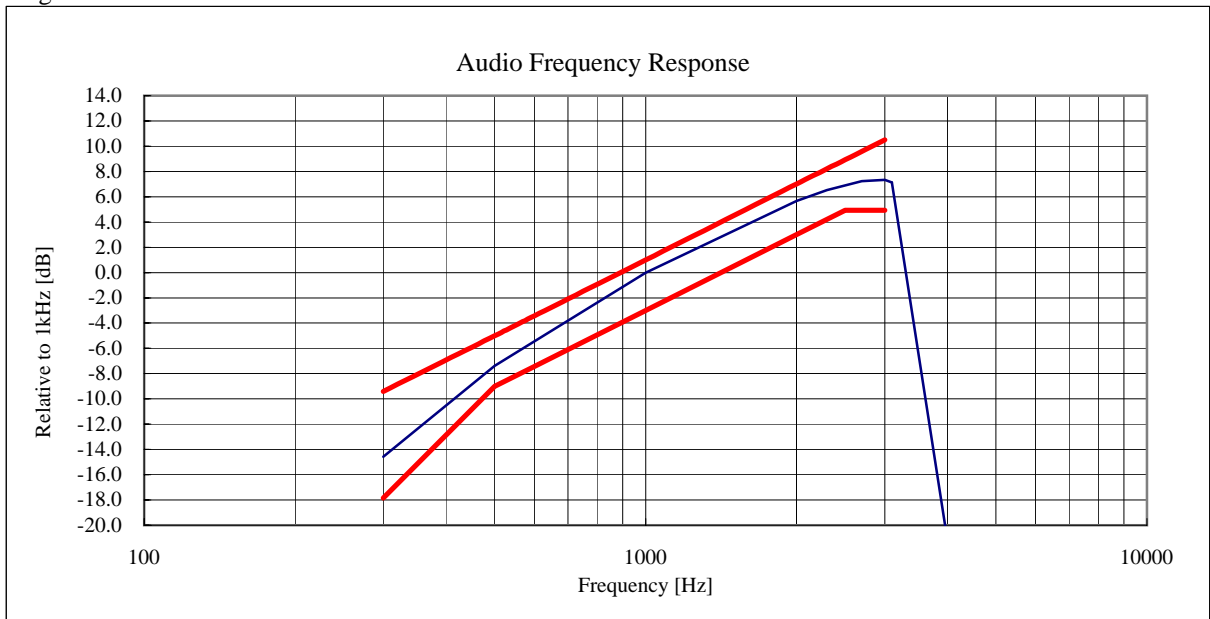

Note:

Audio Filter of the above result is substituted with the same structure as Audio Frequency Resonse. On the transmission condition below 3kHz, Transceiver shows pre-emphasis condition of transmission function.

On the transmission condition above 3kHz, Transceiver shows Audio Low Pass Filter.

**4.7 Modulation Limiting**

REGULATIONS	: 47 CFR 2.1047 (b)
TEST METHOD/GUIDE	: ANSI/TIA/EIA-603B-2002, section 2.2.3.2, 1.3.4.4

**TEST PROCEDURE**

- 1 The EUT and test equipment were set up as shown on the following page.
- 2 Adjust the Modulation Analyzer for the following setting:
  - a) High-pass filter : off
  - b) Low-pass filter : 15 kHz
  - c) Detector : positive peak
  - d) Function : FM
- 3 Apply a 1kHz modulating signal to the transmitter from the audio generator, and adjust the level to obtain 60% of full rated system deviation.
- 4 Measure the modulation frequency that was showed on the Modulation Analyzer when the output levels of the Audio Generator were changed from -20 dB to +50 dB by 10 dB.
- 5 Set the output frequencies of the Audio Generator 300 Hz and 3 kHz, and repeat test procedure 4.
- 6 Set the the Detector of the Modulation Analyzer Negative Peak.
- 7 Repeat test procedure 4 and 5.

**TEST EQUIPMENTS**

No.	Equipment	Manufacture	Model No.	Serial No.	Cal Exp.
1	Audio Generator	ANRITSU	MG443B	1004468	Jun-06
2	Attenuator (20dB)	Weinschel	40-20-34	AA5701	Jul-06
3	Attenuator (30dB)	Weinschel	WA-29-30-34	8923	Jul-06
4	Modulation Analyzer	HP	8901B	3403A04852	Mar-06
5	50Ω Termination	TME	CT-01	None	Oct-06
6	DC Power Supply	DAIWA	PS-3020	None	None
7	Digital Multi Meter	Sanwa	CD721	3215593	Apr-06

**MEASUREMENT EQUIPMENT CONFIGURATION**

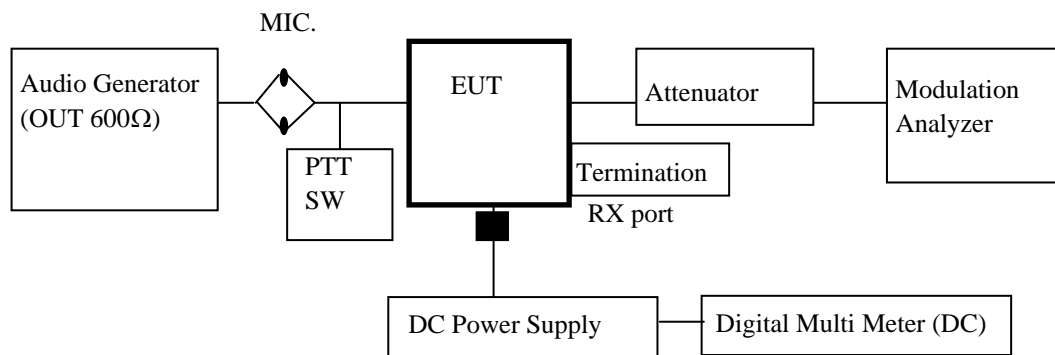

■ :Ferrite core

**UNCERTAINTY**

Measurement uncertainty is +/- 0.8dB (k = 2)

### TEST RESULTS

Measured for the worst case

State : High Power / 12.5 kHz channel bandwidth / 466.525 MHz

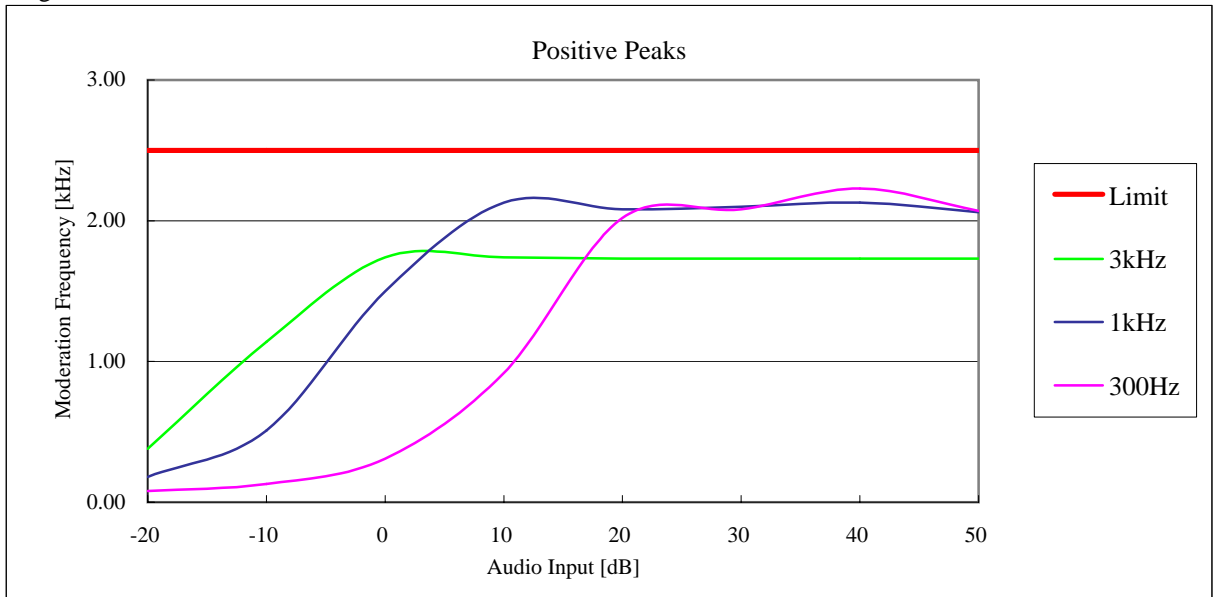

State : High Power / 12.5 kHz channel bandwidth / 466.525 MHz

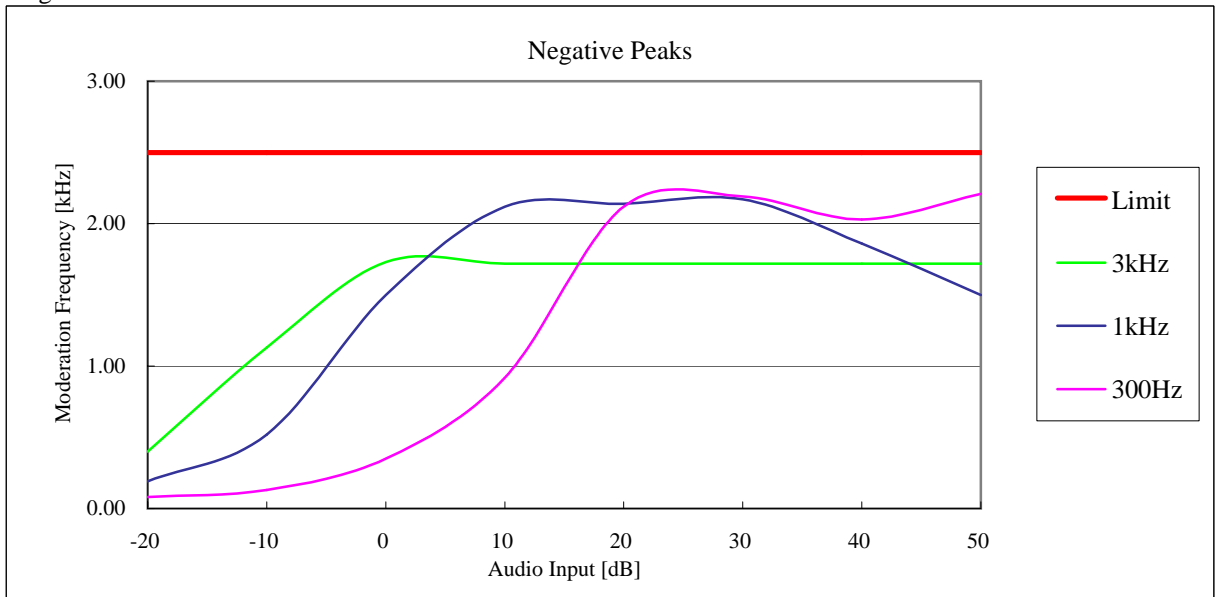



**4.8 Frequency Stability (Temperature Variation)**

REGULATIONS	: 47 CFR 2.1055 (a) (1), 22.355 , 74.1261 (b) , 90.213(a)
TEST METHOD/GUIDE	: ANSI/TIA/EIA-603B-2002, section 2.2.2.2

**TEST PROCEDURE**

- 1 The EUT and test equipment were set up as shown on the following page.
- 2 Set the temperature -30 degrees C.
- 3 Leave the EUT for 1 hour after it became the temperature that was set up.
- 4 Make the EUT the transmitting state.  
Two minutes later, measure the output frequency.
- 5 Make the EUT the receiving state.
- 6 Set the temperature 50 degrees C by 10 degrees C.  
And repeat test procedure 3 to 5.

**TEST EQUIPMENTS**

No.	Equipment	Manufacture	Model No.	Serial No.	Cal Exp.
1	Spectrum Analyzer	Agilent	E7401A	US39440256	Aug-06
2	Attenuator (20dB)	Weinschel	40-20-34	AA5701	Jul-06
3	Attenuator (30dB)	Weinschel	WA-29-30-34	8923	Jul-06
4	50Ω Termination	TME	CT-01	None	Oct-06
5	DC Power Supply	MICKEY	MK-10A	None	None
6	Digital Multimeter	Sanwa	CD721	3215593	Apr-06
7	Temperature Chamber	TABAI	PL-3F	5103661	None
8	Temperature Meter	SATO	PC-5000TRH-II	A14999972	Mar-06

**MEASUREMENT EQUIPMENT CONFIGURATION**

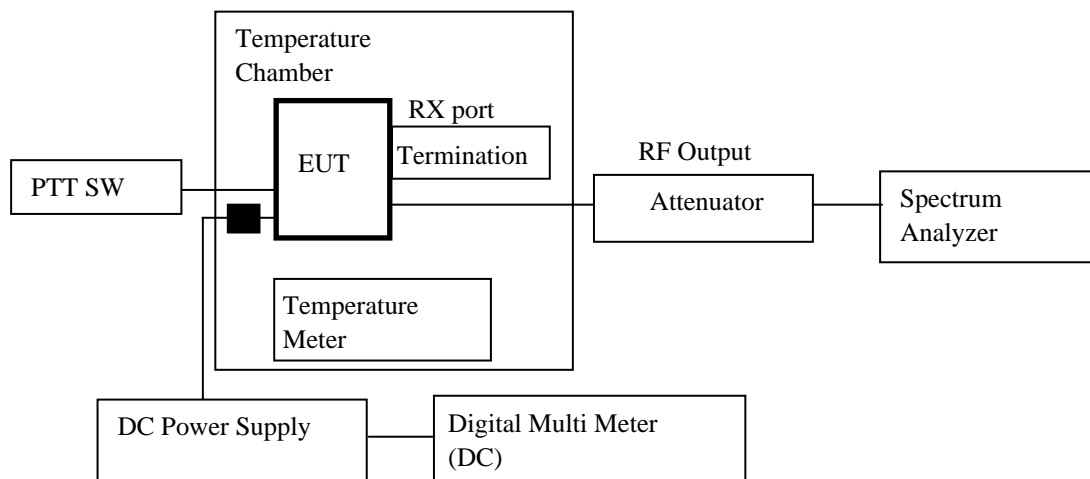

■ : Ferrite core

**UNCERTAINTY**

Measurement uncertainty is +/- 3.6%

**TEST RESULTS**

Measured for the worst case

State : High Power / 12.5 kHz channel bandwidth / 450.025 MHz

No.	Temperature (Degree C)	Frequency (MHz)	Deviation (ppm)	Limit (ppm)
1	-30	450.025064	0.14	0.5
2	-20	450.025048	0.11	0.5
3	-10	450.025017	0.04	0.5
4	0	450.025013	0.03	0.5
5	10	450.025012	0.03	0.5
6	20	450.025008	0.02	0.5
7	30	450.025009	0.02	0.5
8	40	450.025016	0.04	0.5
9	50	450.025036	0.08	0.5

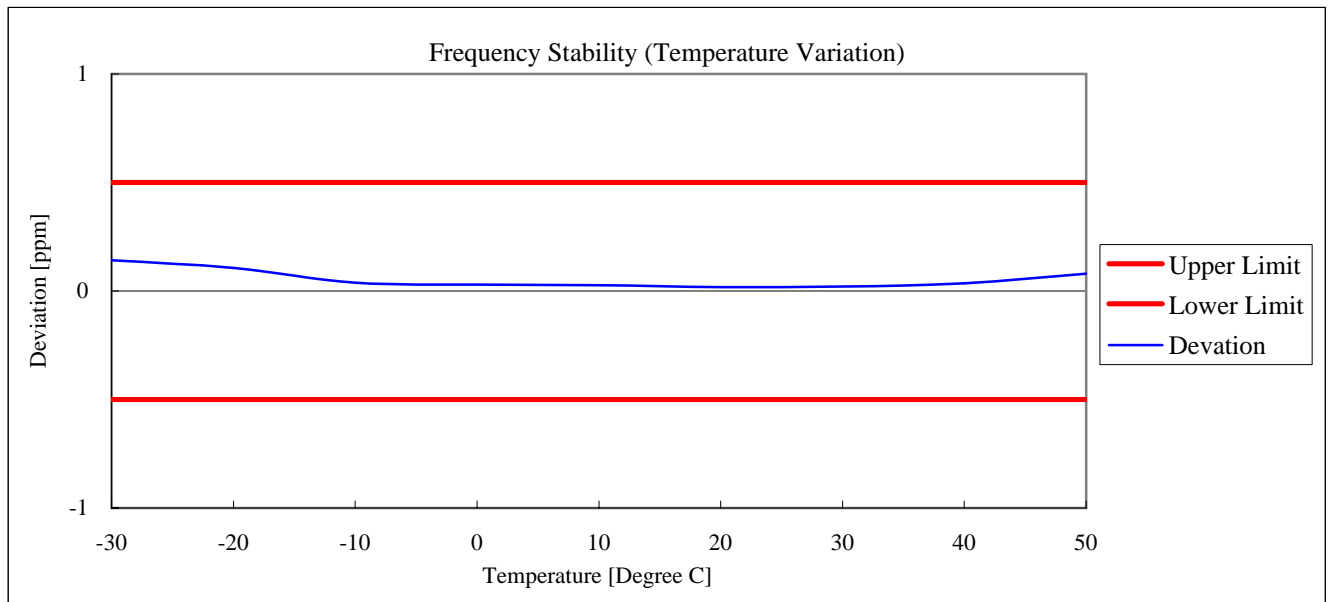

**4.9 Frequency Stability (Voltage Variation)**

REGULATIONS	: 47 CFR 2.1055 (d) (1), 22.355 , 74.1261 (b) , 90.213(a)
TEST METHOD/GUIDE	: ANSI/TIA/EIA-603B-2002, section 2.2.2.2

**TEST PROCEDURE**

- 1 The EUT and test equipment were set up as shown on the following page.
- 2 The power supply voltage to the EUT was varied from 85 % to 115 % of the nominal value measured at the input to the EUT.

**TEST EQUIPMENTS**

No.	Equipment	Manufacture	Model No.	Serial No.	Cal Exp.
1	Spectrum Analyzer	Agilent	E7401A	US39440256	Aug-06
2	Attenuator (20dB)	Weinschel	40-20-34	AA5701	Jul-06
3	Attenuator (30dB)	Weinschel	WA-29-30-34	8923	Jul-06
4	50Ω Termination	TME	CT-01	None	Oct-06
5	DC Power Supply	MICKEY	MK-10A	None	None
6	Digital Multimeter	Sanwa	CD721	3215593	Apr-06
7	Temperature Chamber	TABAI	PL-3F	5103661	None
8	Temperature Meter	SATO	PC-5000TRH-II	A14999972	Mar-06

**MEASUREMENT EQUIPMENT CONFIGURATION**

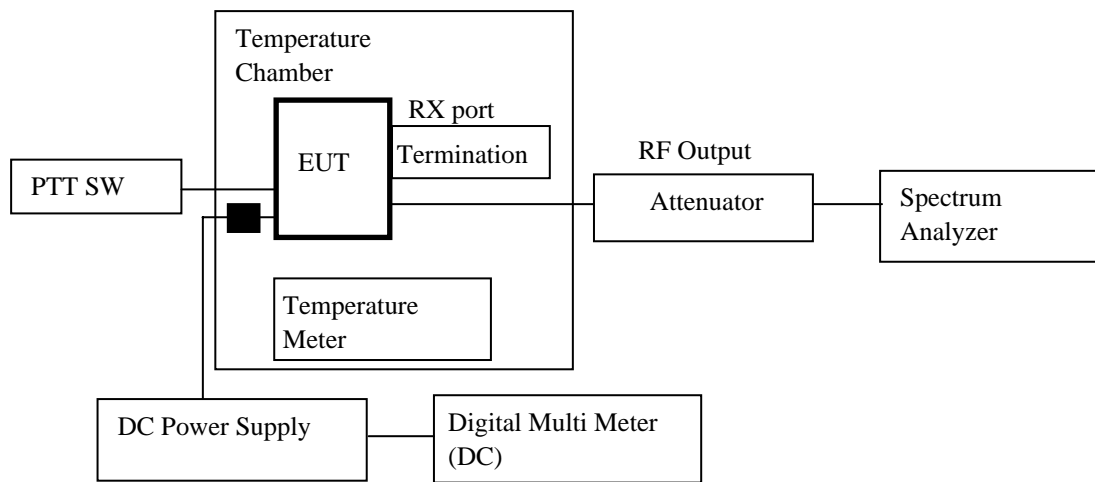

■ : Ferrite core

**UNCERTAINTY**

Measurement uncertainty is +/- 3.6%

**TEST RESULTS**

Measured for the worst case

State : High Power / 12.5 kHz channel bandwidth / 450.025 MHz

No.	Diviation (%)	Voltage (V)	Frequency (MHz)	Deviation (ppm)	Limit (ppm)
1	85	11.7	450.025008	0.02	0.5
2	100	13.8	450.025008	0.02	0.5
3	115	15.9	450.025009	0.02	0.5

**4.10 Necessary Bandwidth and Emission Bandwidth**

REGULATIONS	: 47 CFR 2.202 (g) & Federal Register/ Vol.68, No236
-------------	--

**CALCULATION RESULTS**

State : 11K0F3E(12.5kHz channel bandwidth)

Item	Mark	
Maximum Modulation	(M)	3kHz
Maximum Deviation	(D)	2.5kHz
Constant Factor	(K)	1
Necessary Bandwidth	(Bn)	11kHz

$$B_n = (2 \times M) + (2 \times D \times K)$$

State : 6K00F1E(4Level FSK/4800bps, 6.25kHz channel bandwidth)

Item	Mark	
Digital information rate	(R)	4800bps
Peak frequency deviation	(D)	1.8kHz
Signaling states	(S)	4
Numerical factor	(K)	1
Necessary Bandwidth	(Bn)	6kHz

$$B_n = (R / \log_2 S) + 2 \times D \times K$$

State : 6K00F1D(4Level FSK/4800bps, 6.25kHz channel bandwidth)

Item	Mark	
Digital information rate	(R)	4800bps
Peak frequency deviation	(D)	1.8kHz
Signaling states	(S)	4
Numerical factor	(K)	1
Necessary Bandwidth	(Bn)	6kHz

$$B_n = (R / \log_2 S) + 2 \times D \times K$$

**5. VALIDITY OF TEST REPORT**

The test result of this report is effective for equipment under test itself and under the test configuration described on the report.

This test report does not assure that whether the test result taken in other testing laboratory is compatible or reproducible to the test result on this report or not.

Copying of this report without permission is prohibited.

**6. DESCRIPTION OF TEST LABORATORY**

ACCREDITATION		SCOPE	LAB. CODE
NVLAP	USA	EMC Testing	100290-0
NVLAP	USA	Calibration	100290-0
NVLAP	USA	Telecommunication	100290-0
VLAC	JAPAN	EMC Testing	VLAC-008
BSMI	TAIWAN	EMC Testing	SL2-IN-E-6008
NATA	AUSTRALIA	Calibration	13491
NATA	AUSTRALIA	Telecommunication	100290-0

AUTHORIZATION		SCOPE	LAB. CODE
NEMKO	NORWAY	EMC Testing	ELA107
ETL SEMKO JAPAN	SWEDEN	EMC Testing	9200202558R

FILING		SCOPE	LAB. CODE
FCC	USA	EMC Testing	934283
IC	CANADA	EMC Testing	IC-2065
IC	CANADA	Telecommunication	IC-2065
VCCI	JAPAN	EMC Testing	

Note 1 : NVLAP accreditation does not constitute any product endorsement by NVLAP or any agent of the U.S. Government.