

EXHIBIT NO. 1

GTAMS
System Description

The Ground-To-Air Measurement System (GTAMS) is a ground based radar system used to collect signature data on flying targets. The system is completely self contained (except for electrical power requirements) in a modified 40 ft. semi-trailer. (See figures 1 and 2 for artist's renditions.) The trailer is divided into a 30 ft. housed, systems operation area, and a 10 ft. flatbed section on the rear which will contain the antenna pedestal and radar equipment. The trailer configuration will allow the system to be moved easily from site to site.

GTAMS is being developed by Hughes Aircraft Co. to support on-going efforts in the field of target identification. The system will be used on government contracts to collect data for algorithm development and demonstration programs. GTAMS will employ several different radar waveforms and techniques. These will encompass bandwidth requirements of 7 to 11 GHz, inclusive, using a pulsed, medium PRF signal (1 KHz to 100 KHz), with duty factors up to 50%. The transmitter output power is 200 watts peak, with an antenna gain of approximately 39.5 dB. It is intended that the use of this system will further advance our technology base in the endeavor of target identification.

The system will sequence through three modes of operation in the data collection process. Mode 1 is referred to as Search, where the radar operator in the trailer will have manual control over the antenna positioner, and direct the antenna(s) towards the target of interest. (From the artist's rendition, it can be seen that there are actually three antennas or dishes involved in the system. The top dish in the array is used for transmitting, while the other two are for receive. The transmit antenna is configured to transmit either a vertically or horizontally polarized signal. All dishes are 4 ft. in diameter.) Once the operator has maneuvered the antennas to the line of sight of the target, the next mode is entered.

Mode 2 is the Acquisition phase. Here, the radar operator interacts with the system computer to lock onto the target and track it automatically. The operator is provided feedback on the radar data display that indicates to him prospective range and range rate values. The operator selects the appropriate values and the system takes over from there. Angle tracking commences from the inception of the mode from the last location given in Search Mode.

Mode 3 is the final phase and constitutes the actual data gathering process. This mode is called the Data Collection Mode. Now, signature data is collected on the target using a preprogrammed waveform that correlates to the type signature data that is to be collected and subsequently processed. This waveform is then interlaced with track maintenance waveforms in order to update target tracking. Data is continuously collected on the target as it moves through its flight path in order to ob-

tain data from various aspect angles.

All of the waveforms, in each of the modes, falls within the operating boundaries specified previously.

Part of Exhibit No. 1

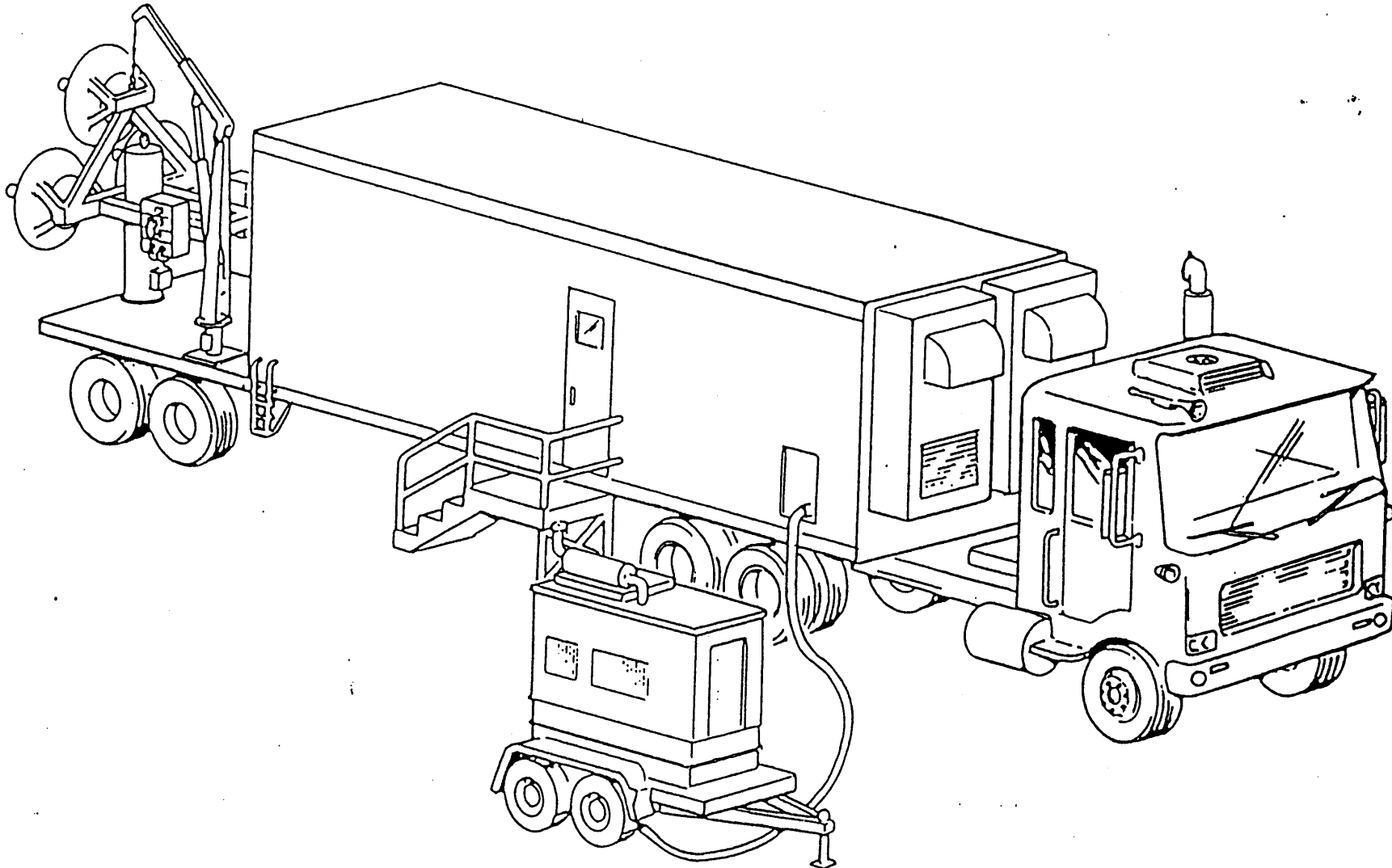

Figure 1 -- GTAMS Trailer Configuration

Part of Exhibit No. 1

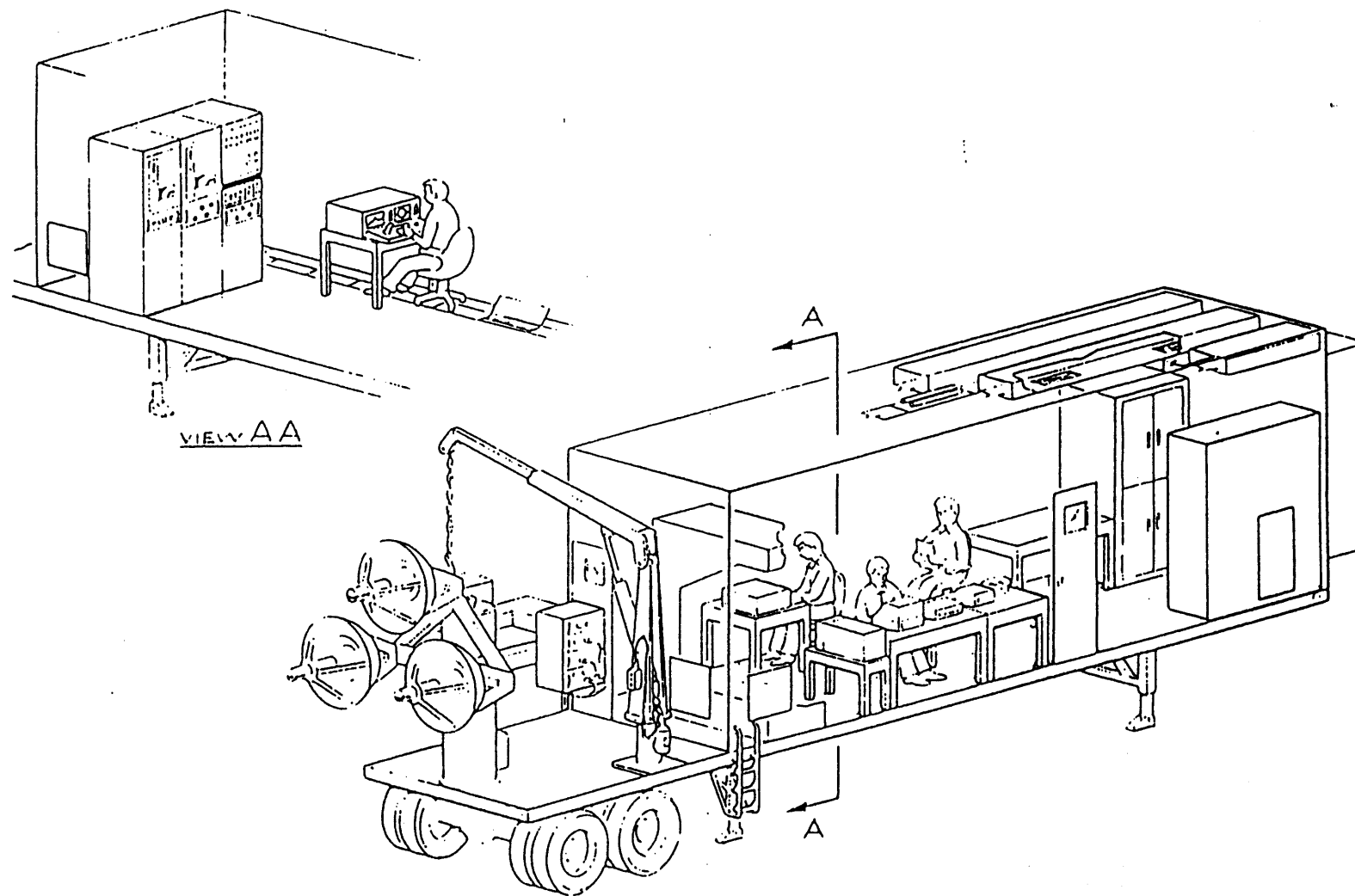

Figure 2 -- GTAMS System Operation View

EXHIBIT NO. 2a

Shown below is a drawing of the GTAMS trailer. A detailed description of the configuration is given in Exhibit No. 1. This drawing is provided to show the dimensions of the supporting structure that the antenna pedestal will be mounted to. The pedestal with antenna array is shown in Exhibit No. 2b. The pedestal will be mounted in the center of the flatbed area (approximately), bolted to the frame of the trailer.

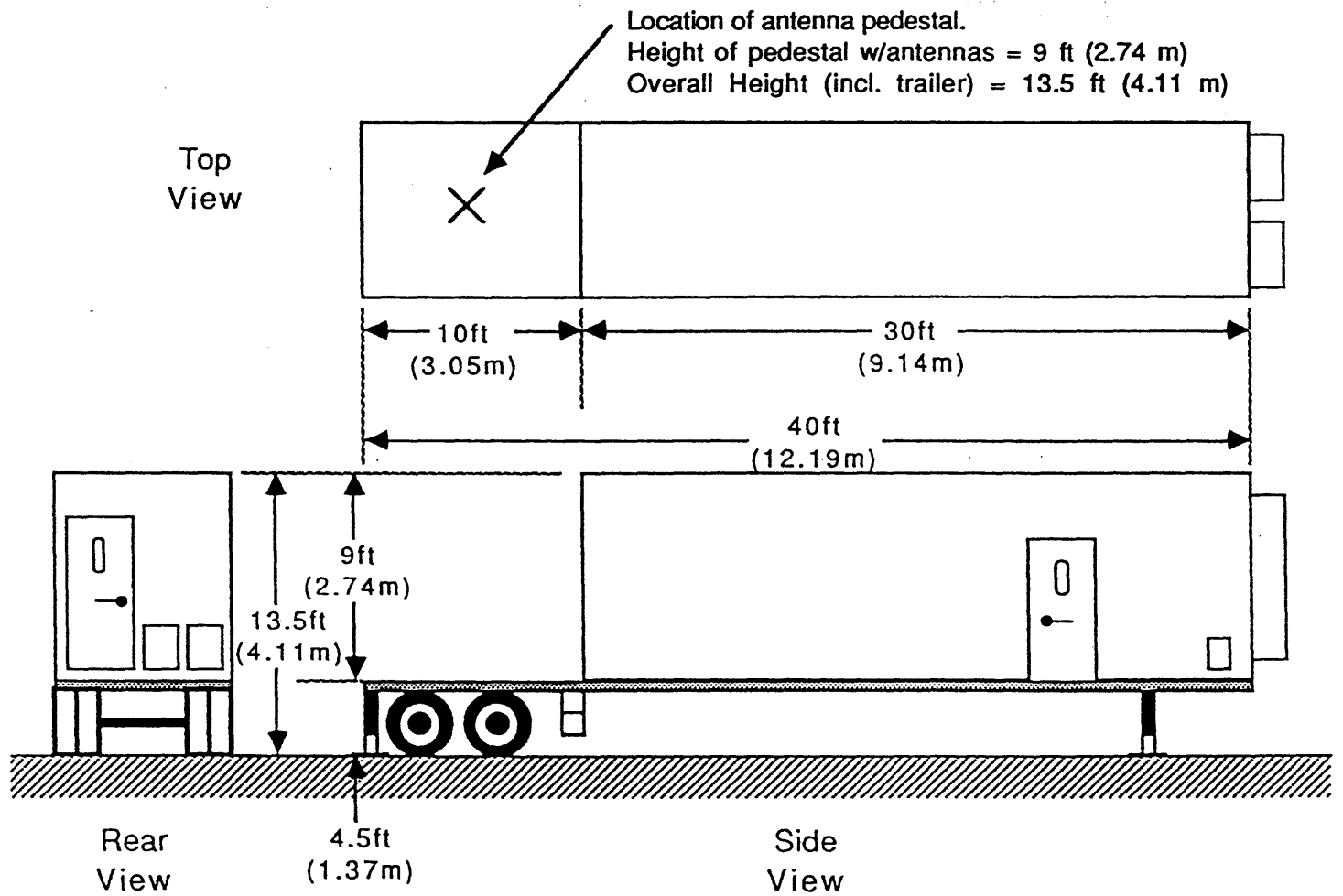

EXHIBIT NO. 3

The following is a list of sites which have been selected for testing of the Hughes GTAMS Radar. At each of the locations, it is feasible to park the GTAMS trailer and view the test targets.

- 1) Naval Ocean Systems Center, San Diego, Ca
Latitude: 32 degrees 42' 12" N
Longitude: 117 degrees 15' 15" W
- 2) Hughes, Culver City, Ca
Latitude: 33 degrees 58' 56" N
Longitude: 118 degrees 24' 37" W
- 3) Edwards Air Force Base, Ca
Latitude: 35 degrees 55' 00" N
Longitude: 117 degrees 52' 00" W
- 4) Point Mugu Naval Test Center, Oxnard Ca
Latitude: 34 degrees 06' 46" N
Longitude: 119 degrees 07' 18" W
- 5) Eglin Air Force Test Center, Fla
Latitude: 30 degrees 31' 19" N
Longitude: 86 degrees 19' 02" W
- 6) Nellis Air Force Base, NV
Latitude: 36 degrees 14' 11" N
Longitude: 115 degrees 20' 03" W
- 7) Tyndall Air Force Base, Fla
Latitude: 30 degrees 04' 08" N
Longitude: 85 degrees 35' 05" W
- 8) Hughes, Malibu, Ca
Latitude: 34 degrees 02' 30" N
Longitude: 118 degrees 42' 00" W

EXHIBIT NO. 3 cont'd

- 9) Hughes, Canoga Park, Ca
Latitude: 34 degrees 13' 24" N
Longitude: 118 degrees 37' 32" W

- 10) Hughes, Fullerton, Ca
Latitude: 33 degrees 52' 53" N
Longitude: 117 degrees 57' 49" W

- 11) Hughes, El Segundo, Ca
Latitude: 33 degrees 55' 48" N
Longitude: 118 degrees 23' 25" W