

Exhibit #2

GPS Re-Radiation System Technical Description

GM proposes to install the seven (7) fixed GPS re-radiation GLI-Metro-G repeaters which will be located indoors in the test crash hall, which is a facility/building located at the General Motors Milford Proving Grounds in Milford, Michigan. The building in question is used exclusively for GM operations to conduct vehicle crash testing and telematics system testing under a variety of constraints and scenarios.

A total of two rooftop active antennas (one existing, one new) will be used and locations are as follows:

No.	Rooftop Antenna (receives GPS signal from satellites)	Latitude	Longitude	Location
1.	Active Antenna	FCC license acquired already		
2.	Active Antenna	42°33'52.76"N	83°40'42.19"W	Outdoor/Rooftop

The locations of the GPS Repeaters (with their attached passive transmitting antennas) for which GMRC seeks approval are given in the following table. Repeater 1 is existing and an FCC license has already been acquired for it; only a change in power level and elimination of L2 is being proposed. GMRC proposes to add Repeaters 2, 3, 4, 5, 6, 7, and 8 to the license.

Repeater	Transmitting Equipment	Latitude	Longitude	Location
1	GLI-Metro-G Repeater	42°33'56.60"N	83°40'42.70"W	Indoor
2	GLI-Metro-G Repeater	42°33'55.53"N	83°40'42.70"W	Indoor
3	GLI-Metro-G Repeater	42°33'54.41"N	83°40'42.70"W	Indoor
4	GLI-Metro-G Repeater	42°33'53.29"N	83°40'42.70"W	Indoor
5	GLI-Metro-G Repeater	42°33'54.53"N	83°40'42.41"W	Indoor
6	GLI-Metro-G Repeater	42°33'53.54"N	83°40'42.41"W	Indoor
7	GLI-Metro-G Repeater	42°33'52.54"N	83°40'42.41"W	Indoor
8	GLI-Metro-G Repeater	42°33'52.54"N	83°40'42.53"W	Indoor

Below is the system diagram of the crash test facility, showing the GPS repeater locations.

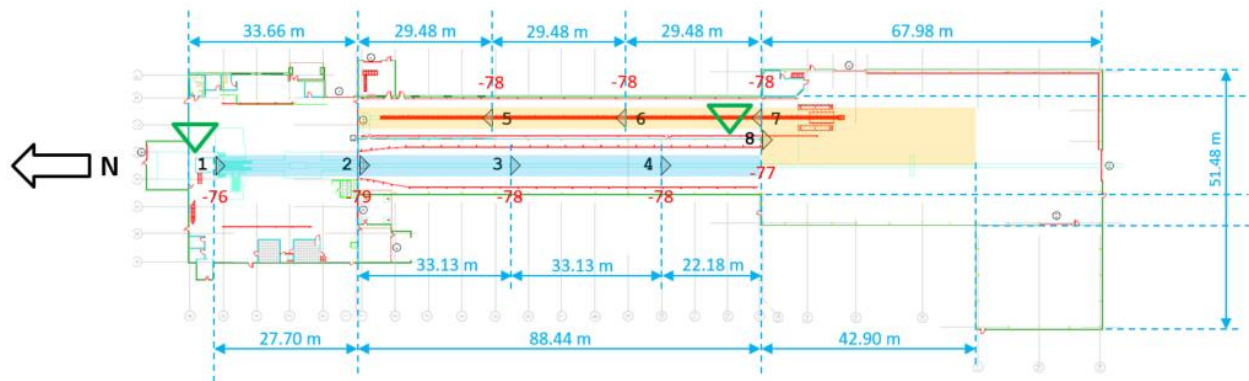

Legend:

-  = Rooftop antenna (outdoors)
-  = GNSS repeater (with attached antenna)¹
-  = Areas requiring coverage
-  = Areas requiring coverage
-  = Repeater power setting (dBm ERP)

NOTE 1: Repeater to be located at center of base of triangle. Orientation of repeater indicated by which way triangle points. E.g. Repeater 1 points south.

Below is the aerial view of the crash test facility with the GPS repeater locations (1 is existing; 2, 3, 4, 5, 6, 7, and 8 are proposed).



Emission Calculations

Emission calculation per antenna/GPS repeater¹ are explained below, and compliance with Redbook section 8.3.27 is demonstrated.

The calculations are performed based on the fact that the antennas are directional.²

All of the repeaters re-radiate L1.³

Power Settings

The GPS repeater offers an output power setting, which is a whole number from -85 to -65 inclusive. It specifies the output power of the repeater, which is then supplied to the passive transmitting antenna that is attached to the repeater. The proposed output power settings in order to receive good coverage in the crash test facility are as below:

Repeater	Transmit ERP L1	Units
1	-76	dBm
2	-79	dBm
3	-78	dBm
4	-78	dBm
5	-78	dBm
6	-78	dBm
7	-78	dBm
8	-77	dBm

Assessment against 8.3.27 section “e”

Section 8.3.27 of the NTIA “Manual of Regulations and Procedures for Federal Radio Frequency Management (Redbook)”, Sept 2017 Revision of the Sept 2015 edition, states the following in section “e”:

“The area of potential interference to GPS reception (e.g., military or contractor facility) has to be under the control of the user.”

The crash test facility (the building shown earlier) is located inside the GM Milford Proving Grounds, which is a large private access controlled campus surrounded by a fence. Thus this campus, the crash test facility, and indeed the area of potential interference, are under the control of the user.

¹ Each GPS re-radiator consists of a repeater with an attached passive transmitting antenna.

² See “Explanation of Gain Values Used” section for explanation.

³ Previously Repeater 1 re-radiated both L1 and L2, but GMRC proposes to replace this repeater’s antenna with an antenna that supports only L1.

Assessment against 8.3.27 section “f”

Maximum Permissible EIRP

Section “f” imposes a maximum permissible EIRP in dBm called “ P_{Tmax} ”, which is calculated according to the following formula:

$$P_{Tmax} = P_R + 20 \log_{10} f + 20 \log_{10}(30 + d) - 27.55$$

Where:

P_{Tmax} is the maximum permissible EIRP in dBm

P_R is the power received at 30 meters from the building (i.e. -140 dBm/24 MHz)

f is frequency in MHz (i.e. 1575.42 for L1, 1227.60 for L2, 1176.45 for L5)

d is the distance between the radiator and the closest exterior wall of the building in meters.

This requirement is met for each repeater. Below are the calculations of maximum permissible EIRP and actual EIRP for each repeater:⁴

⁴ The antenna gain values used in these calculations are explained in the “Explanation of Gain Values Used” section later in this document.

Antenna 1 - L1 Maximum Permissible EIRP				
Label	Parameter	Value	Units	Notes / Formula
A	P_R	-140	dBm	Power received at 30 meters from the building
B	f	1575.42	MHz	L1 center frequency
C	d	7.26	meters	Distance between the radiator and the closest exterior wall of the building
D	P_{Tmax}	-72.2	dBm	Maximum permissible EIRP = $A + 20 * \log(B) + 20 * \log(30 + C) - 27.55$
E	P_{Tmax}	60.6	pW	Maximum permissible EIRP = $10^{(D/10)+9}$

Antenna 1 - L1 Actual EIRP				
Label	Parameter	Value	Units	Notes / Formula
A	Transmit ERP from repeater	-76	dBm	
B	Transmit ERP from repeater	25.1	pW	= $10^{(A/10)+9}$
C	Transmit EIRP from repeater	-73.85	dBm	= $A + 2.15$
D	Antenna Gain	1.17	dB	Gain of repeater's antenna in direction of closest exterior wall
E	Transmit EIRP from repeater's antenna	-72.7	dBm	= $C + D$
F	Transmit EIRP from repeater's antenna	53.9	pW	= $10^{(E/10)+9}$

The actual EIRP for Repeater 1 (-72.7 dBm = 53.9 pW) is less than the maximum permissible EIRP for this repeater (-72.2 dBm = 60.6 pW).

Antenna 2 - L1 Maximum Permissible EIRP				
Label	Parameter	Value	Units	Notes / Formula
A	P_R	-140	dBm	Power received at 30 meters from the building
B	f	1575.42	MHz	L1 center frequency
C	d	9.24	meters	Distance between the radiator and the closest exterior wall of the building
D	P_{Tmax}	-71.7	dBm	Maximum permissible EIRP = $A + 20 * \log(B) + 20 * \log(30 + C) - 27.55$
E	P_{Tmax}	67.2	pW	Maximum permissible EIRP = $10^{(D/10)+9}$

Antenna 2 - L1 Actual EIRP				
Label	Parameter	Value	Units	Notes / Formula
A	Transmit ERP from repeater	-79	dBm	
B	Transmit ERP from repeater	12.6	pW	= $10^{(A/10)+9}$
C	Transmit EIRP from repeater	-76.85	dBm	= $A + 2.15$
D	Antenna Gain	4.33	dB	Gain of repeater's antenna in direction of closest exterior wall
E	Transmit EIRP from repeater's antenna	-72.5	dBm	= $C + D$
F	Transmit EIRP from repeater's antenna	56.0	pW	= $10^{(E/10)+9}$

The actual EIRP for Repeater 2 (-72.5 dBm = 56 pW) is less than the maximum permissible EIRP for this repeater (-71.7 dBm = 67.2 pW).

Antenna 3 - L1 Maximum Permissible EIRP

Label	Parameter	Value	Units	Notes / Formula
A	P_R	-140	dBm	Power received at 30 meters from the building
B	f	1575.42	MHz	L1 center frequency
C	d	5.94	meters	Distance between the radiator and the closest exterior wall of the building
D	P_{Tmax}	-72.5	dBm	Maximum permissible EIRP = $A + 20 * \log(B) + 20 * \log(30 + C) - 27.55$
E	P_{Tmax}	56.4	pW	Maximum permissible EIRP = $10^{(D/10)+9}$

Antenna 3 - L1 Actual EIRP

Label	Parameter	Value	Units	Notes / Formula
A	Transmit ERP from repeater	-78	dBm	
B	Transmit ERP from repeater	15.8	pW	= $10^{(A/10)+9}$
C	Transmit EIRP from repeater	-75.85	dBm	= $A + 2.15$
D	Antenna Gain	2.50	dB	Gain of repeater's antenna in direction of closest exterior wall
E	Transmit EIRP from repeater's antenna	-73.4	dBm	= $C + D$
F	Transmit EIRP from repeater's antenna	46.2	pW	= $10^{(E/10)+9}$

The actual EIRP for Repeater 3 (-73.4 dBm = 46.2 pW) is less than the maximum permissible EIRP for this repeater (-72.5 dBm = 56.4 pW).

Antenna 4 - L1 Maximum Permissible EIRP

Label	Parameter	Value	Units	Notes / Formula
A	P_R	-140	dBm	Power received at 30 meters from the building
B	f	1575.42	MHz	L1 center frequency
C	d	5.94	meters	Distance between the radiator and the closest exterior wall of the building
D	P_{Tmax}	-72.5	dBm	Maximum permissible EIRP = $A + 20 * \log(B) + 20 * \log(30 + C) - 27.55$
E	P_{Tmax}	56.4	pW	Maximum permissible EIRP = $10^{(D/10)+9}$

Antenna 4 - L1 Actual EIRP

Label	Parameter	Value	Units	Notes / Formula
A	Transmit ERP from repeater	-78	dBm	
B	Transmit ERP from repeater	15.8	pW	= $10^{(A/10)+9}$
C	Transmit EIRP from repeater	-75.85	dBm	= $A + 2.15$
D	Antenna Gain	2.50	dB	Gain of repeater's antenna in direction of closest exterior wall
E	Transmit EIRP from repeater's antenna	-73.4	dBm	= $C + D$
F	Transmit EIRP from repeater's antenna	46.2	pW	= $10^{(E/10)+9}$

The actual EIRP for Repeater 4 (-73.4 dBm = 46.2 pW) is less than the maximum permissible EIRP for this repeater (-72.5 dBm = 56.4 pW).

Antenna 5 - L1 Maximum Permissible EIRP

Label	Parameter	Value	Units	Notes / Formula
A	P_R	-140	dBm	Power received at 30 meters from the building
B	f	1575.42	MHz	L1 center frequency
C	d	4.62	meters	Distance between the radiator and the closest exterior wall of the building
D	P_{Tmax}	-72.8	dBm	Maximum permissible EIRP = $A + 20 * \log(B) + 20 * \log(30 + C) - 27.55$
E	P_{Tmax}	52.3	pW	Maximum permissible EIRP = $10^{(D/10)+9}$

Antenna 5 - L1 Actual EIRP

Label	Parameter	Value	Units	Notes / Formula
A	Transmit ERP from repeater	-78	dBm	
B	Transmit ERP from repeater	15.8	pW	= $10^{(A/10)+9}$
C	Transmit EIRP from repeater	-75.85	dBm	= $A + 2.15$
D	Antenna Gain	2.50	dB	Gain of repeater's antenna in direction of closest exterior wall
E	Transmit EIRP from repeater's antenna	-73.4	dBm	= $C + D$
F	Transmit EIRP from repeater's antenna	46.2	pW	= $10^{(E/10)+9}$

The actual EIRP for Repeater 5 (-73.4 dBm = 46.2 pW) is less than the maximum permissible EIRP for this repeater (-72.8 dBm = 52.3 pW).

Antenna 6 - L1 Maximum Permissible EIRP

Label	Parameter	Value	Units	Notes / Formula
A	P_R	-140	dBm	Power received at 30 meters from the building
B	f	1575.42	MHz	L1 center frequency
C	d	4.62	meters	Distance between the radiator and the closest exterior wall of the building
D	P_{Tmax}	-72.8	dBm	Maximum permissible EIRP = $A + 20 * \log(B) + 20 * \log(30 + C) - 27.55$
E	P_{Tmax}	52.3	pW	Maximum permissible EIRP = $10^{(D/10)+9}$

Antenna 6 - L1 Actual EIRP

Label	Parameter	Value	Units	Notes / Formula
A	Transmit ERP from repeater	-78	dBm	
B	Transmit ERP from repeater	15.8	pW	= $10^{(A/10)+9}$
C	Transmit EIRP from repeater	-75.85	dBm	= $A + 2.15$
D	Antenna Gain	2.50	dB	Gain of repeater's antenna in direction of closest exterior wall
E	Transmit EIRP from repeater's antenna	-73.4	dBm	= $C + D$
F	Transmit EIRP from repeater's antenna	46.2	pW	= $10^{(E/10)+9}$

The actual EIRP for Repeater 6 (-73.4 dBm = 46.2 pW) is less than the maximum permissible EIRP for this repeater (-72.8 dBm = 52.3 pW).

Antenna 7 - L1 Maximum Permissible EIRP

Label	Parameter	Value	Units	Notes / Formula
A	P_R	-140	dBm	Power received at 30 meters from the building
B	f	1575.42	MHz	L1 center frequency
C	d	4.62	meters	Distance between the radiator and the closest exterior wall of the building
D	P_{Tmax}	-72.8	dBm	Maximum permissible EIRP = $A + 20 * \log(B) + 20 * \log(30 + C) - 27.55$
E	P_{Tmax}	52.3	pW	Maximum permissible EIRP = $10^{(D/10)+9}$

Antenna 7 - L1 Actual EIRP

Label	Parameter	Value	Units	Notes / Formula
A	Transmit ERP from repeater	-78	dBm	
B	Transmit ERP from repeater	15.8	pW	= $10^{(A/10)+9}$
C	Transmit EIRP from repeater	-75.85	dBm	= $A + 2.15$
D	Antenna Gain	2.50	dB	Gain of repeater's antenna in direction of closest exterior wall
E	Transmit EIRP from repeater's antenna	-73.4	dBm	= $C + D$
F	Transmit EIRP from repeater's antenna	46.2	pW	= $10^{(E/10)+9}$

The actual EIRP for Repeater 7 (-73.4 dBm = 46.2 pW) is less than the maximum permissible EIRP for this repeater (-72.8 dBm = 52.3 pW).

Antenna 8 - L1 Maximum Permissible EIRP

Label	Parameter	Value	Units	Notes / Formula
A	P_R	-140	dBm	Power received at 30 meters from the building
B	f	1575.42	MHz	L1 center frequency
C	d	8.58	meters	Distance between the radiator and the closest exterior wall of the building
D	P_{Tmax}	-71.9	dBm	Maximum permissible EIRP = $A + 20 * \log(B) + 20 * \log(30 + C) - 27.55$
E	P_{Tmax}	64.9	pW	Maximum permissible EIRP = $10^{(D/10)+9}$

Antenna 8 - L1 Actual EIRP

Label	Parameter	Value	Units	Notes / Formula
A	Transmit ERP from repeater	-77	dBm	
B	Transmit ERP from repeater	20.0	pW	= $10^{(A/10)+9}$
C	Transmit EIRP from repeater	-74.85	dBm	= $A + 2.15$
D	Antenna Gain	2.50	dB	Gain of repeater's antenna in direction of closest exterior wall
E	Transmit EIRP from repeater's antenna	-72.4	dBm	= $C + D$
F	Transmit EIRP from repeater's antenna	58.2	pW	= $10^{(E/10)+9}$

The actual EIRP for Repeater 8 (-72.4 dBm = 58.2 pW) is less than the maximum permissible EIRP for this repeater (-71.9 dBm = 64.9 pW).

The following table summarizes the above:

Repeater	Maximum Permissible EIRP (dBm/pW)	Actual EIRP (dBm/pW)	Actual EIRP is less than maximum permissible EIRP?
1	-72.2 / 60.6	-72.7 / 53.9	YES
2	-71.7 / 67.2	-72.5 / 56.0	YES
3	-72.5 / 56.4	-73.4 / 46.2	YES
4	-72.5 / 56.4	-73.4 / 46.2	YES
5	-72.8 / 52.3	-73.4 / 46.2	YES
6	-72.8 / 52.3	-73.4 / 46.2	YES
7	-72.8 / 52.3	-73.4 / 46.2	YES
8	-71.9 / 64.9	-72.4 / 58.2	YES

Distance to Nearest Exterior Wall

Section “F” also requires the following: “Applications requesting power greater than the PT_{max} calculated at $d = 0$ meters (i.e. 39.3 pW for L1...) must provide the distance from the transmit antenna to the nearest exterior wall so that reviewing agencies can determine if the requested power meets the maximum EIRP described above.”

The following table provides the distance from each repeater’s transmit antenna to the nearest exterior wall.⁵

Repeater	Distance to nearest exterior wall (meters)
1	7.26
2	9.24
3	5.94
4	5.94
5	4.62
6	4.62
7	4.62
8	8.58

Explanation of Gain Values Used

The antennas attached to the repeaters are directional, i.e. the gain of the antenna varies as a function of azimuth with respect to the antenna. Therefore in the “Maximum Permissible EIRP” section above the gain value that is used for each repeater is the one corresponding to the azimuth of a line drawn from the antenna to the closest exterior wall. The purpose of this section is to explain the antenna’s

⁵ These are the same figures used in the earlier calculations for “Maximum Permissible EIRP”.

gain values as a function of azimuth, and after that to show how this is used to obtain the gain value to use for each repeater.

The antenna that is used for each repeater is the L1G1P “GNSS L1/G1/E1 Passive Antenna” from GPS Source. The following polar plot, taken from the antenna’s data sheet⁶, shows the gain as a function of azimuth:

2.1 L1 Radiation Pattern

Figure 2-1. Measured at 1575 MHz

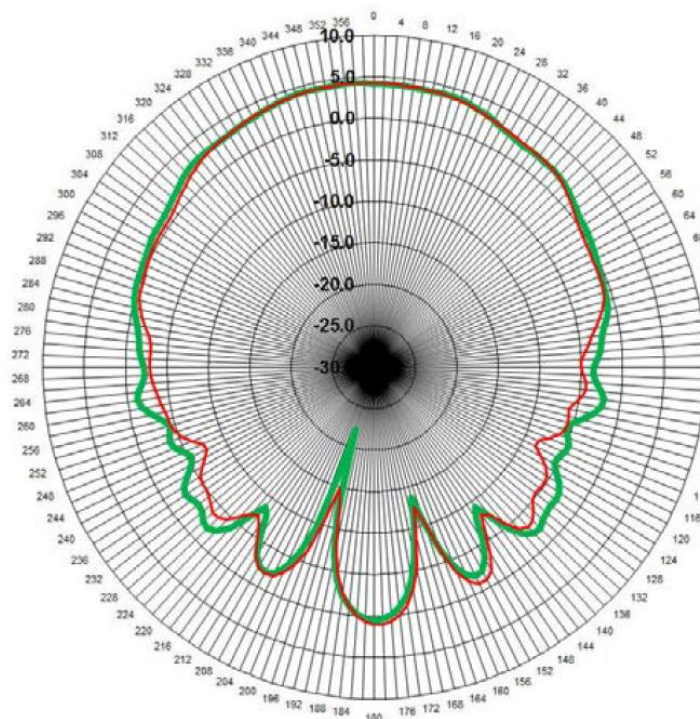

⁶ Technical Product Data Sheet L1G1P GNSS L1/G1/E1 Passive Antenna, document number 059-FAN-AKD-AAZ-PYZ-001, dated 12/22/2016, filename “L1G1-Passive-GNSS-Antenna-Wireless-059-FAN-AKD-AAZ-PYZ-001.pdf”. Obtained from GPS Source.

To simplify the calculations, the above polar plot is simplified to the following “pie slice” depiction:

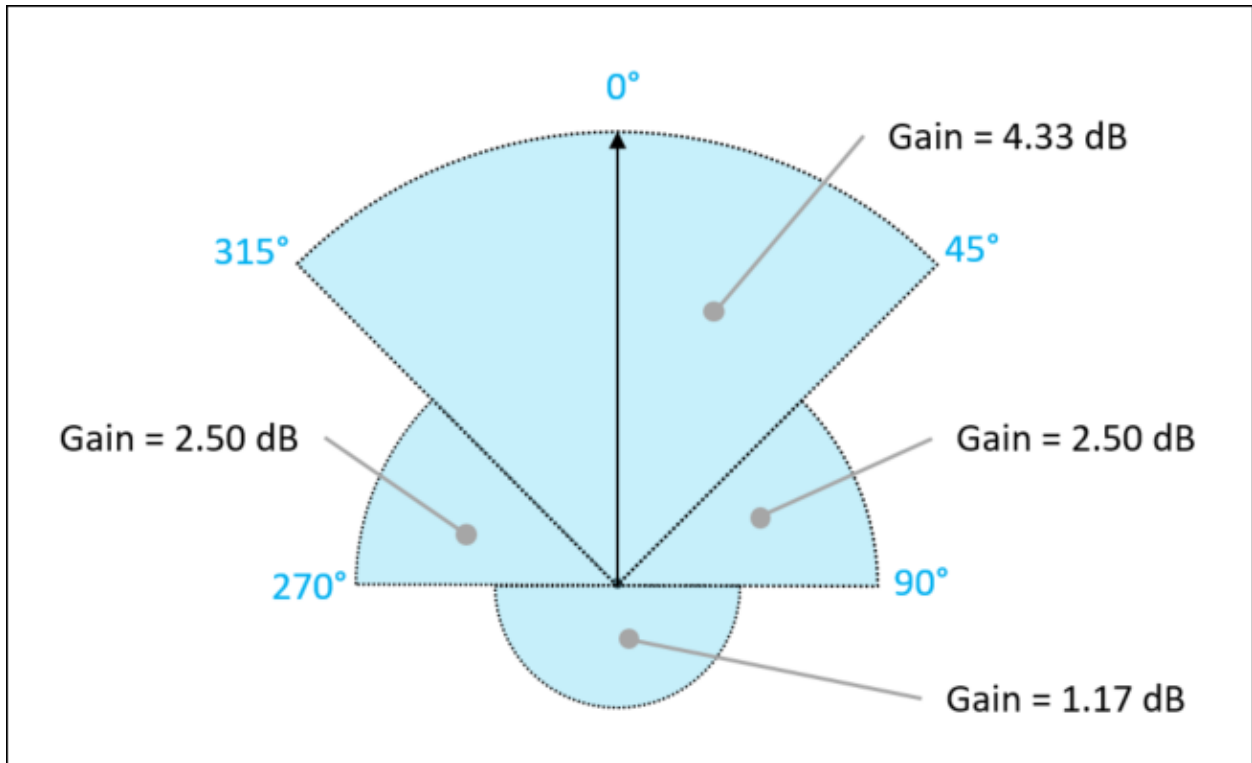

The above simplified polar plot does not understate the gain at any azimuth and in fact overstates it in many cases. This conservative approach ensures that this simplification never falsely indicates compliance with Redbook section 8.3.27.

Below is the diagram of the crash test facility, with a dashed arrow drawn from each repeater to the closest exterior wall.⁷

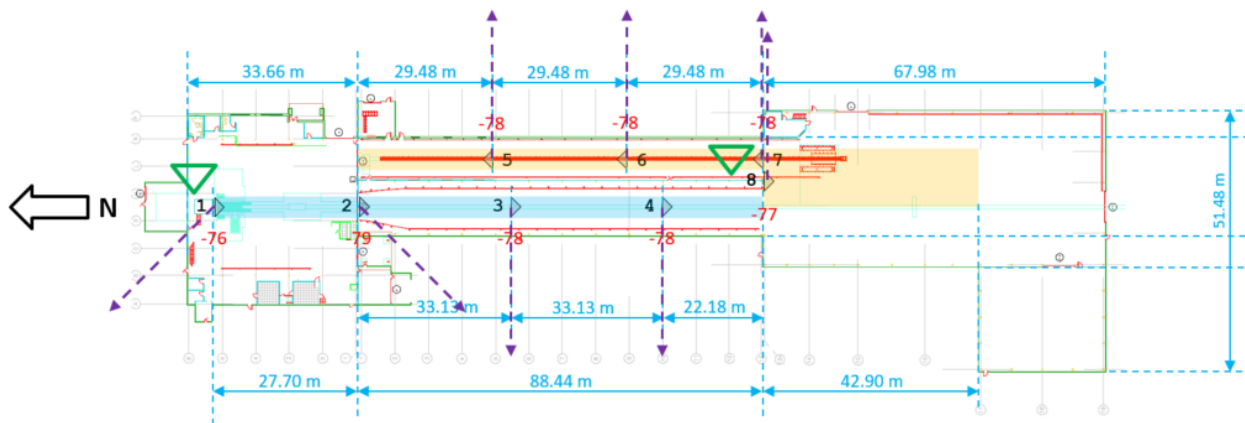

⁷ For legibility the arrows are drawn beyond the wall. The length of the arrows is not meaningful.

The following table shows the azimuth (with respect to antenna orientation) for each dashed arrow, as well as the corresponding antenna gain value.⁸

Repeater	Azimuth to closest exterior wall (degrees)	Antenna gain (dB)
1	135	1.17
2	45	4.33
3	90	2.50
4	90	2.50
5	90	2.50
6	90	2.50
7	90	2.50
8	270	2.50

Supplement – Graphical Depictions of Signal Strength

From the “simplified polar plot” of gain shown above, calculations were performed to determine the distance to which a signal strength higher than -140 dBm EIRP extends from the repeater, as a function of both azimuth and of power setting. The calculations are provided later in this document in the section “Appendix – Calculations for Signal Strength Depictions”. The following table summarizes the results of those calculations:

Power Setting a.k.a. Transmit ERP L1 (dBm)	How far (in meters) signal strength of -140 dBm EIRP extends from repeater		
	315-45 degrees	45-90 degrees, 270-315 degrees	90-270 degrees
-79	35.83	29.01	24.89
-78	40.20	32.55	27.92
-77	45.11	36.53	31.33
-76	50.61	40.98	35.15

From the results in the above table, graphical “pie slice” depictions of signal strength were prepared for various combinations of power setting and azimuth range. Finally, for each repeater appropriate signal strength depiction was laid on top of the crash test facility diagram at that repeater’s proposed location. The results of that exercise are shown in the eight figures that follow.

How to read the figures:

- Direction of black arrow indicates which way the repeater’s antenna will be pointed.
- Pink shaded region indicates the area surrounding the repeater where signal strength is higher than -140 dBm EIRP.

⁸ These are the gain values used in the “Maximum Permissible EIRP” section above.

- Purple bars, 30 meters in length, are placed in various locations to show 30 meter distance from the building.

The below eight figures confirm that for each repeater the signal strength is at or below -140 dBm EIRP at 30 meters from the building.

Pink shows area where signal strength is higher than -140 dBm EIRP for **Repeater 1**, set to -76 dBm ERP:

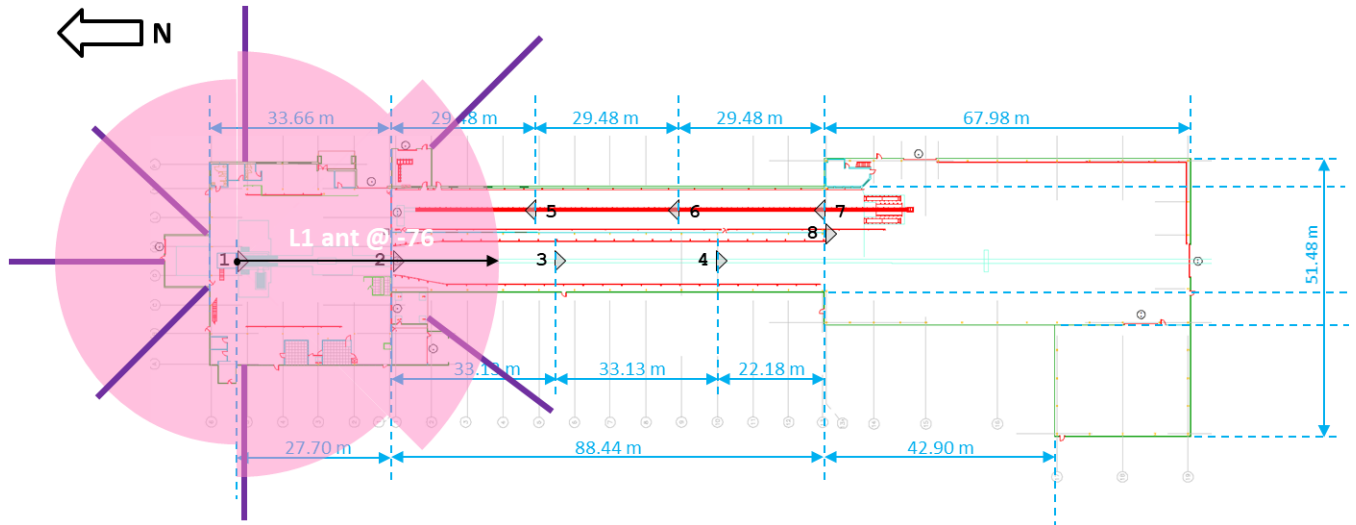

Pink shows area where signal strength is higher than -140 dBm EIRP for **Repeater 2**, set to -79 dBm ERP:

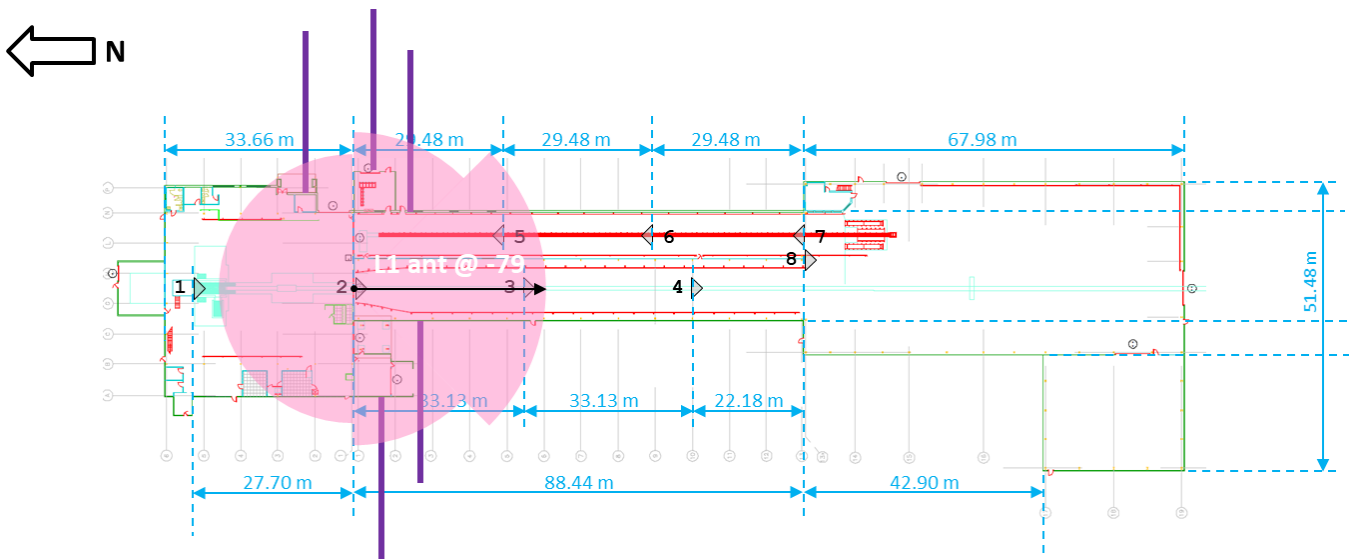

Pink shows area where signal strength is higher than -140 dBm EIRP for **Repeater 3**, set to -78 dBm ERP:

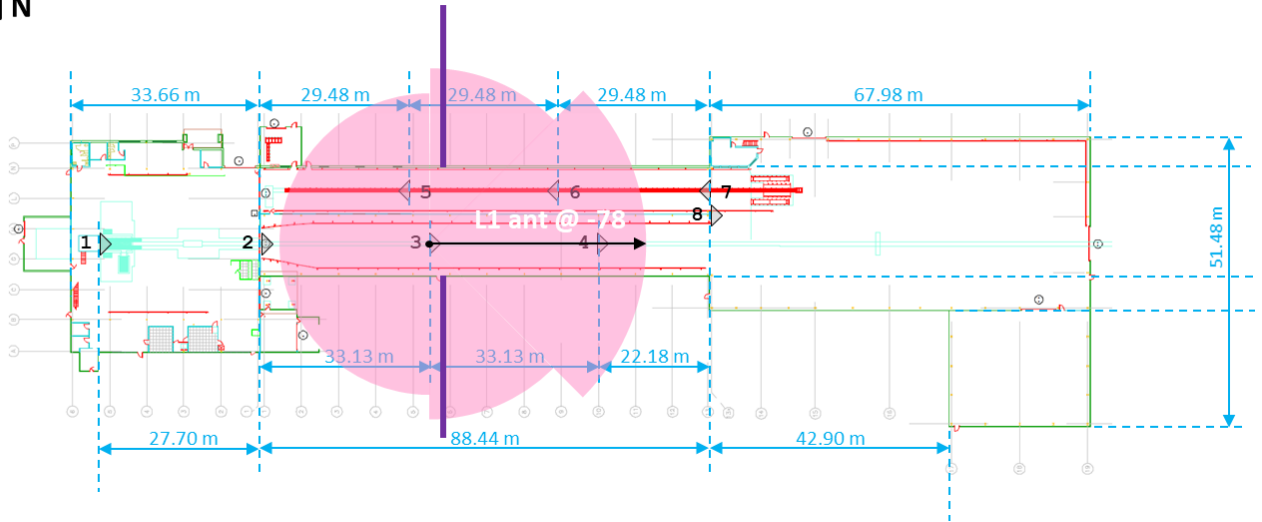
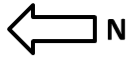

Pink shows area where signal strength is higher than -140 dBm EIRP for **Repeater 4**, set to -78 dBm ERP:

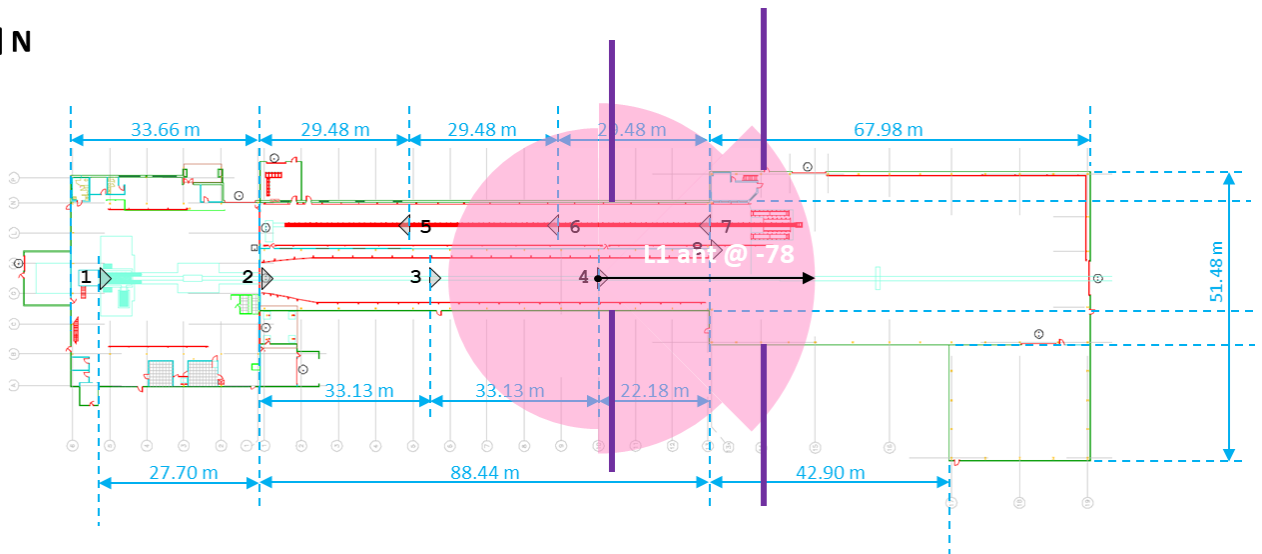

Pink shows area where signal strength is higher than -140 dBm EIRP for **Repeater 5**, set to -78 dBm ERP:

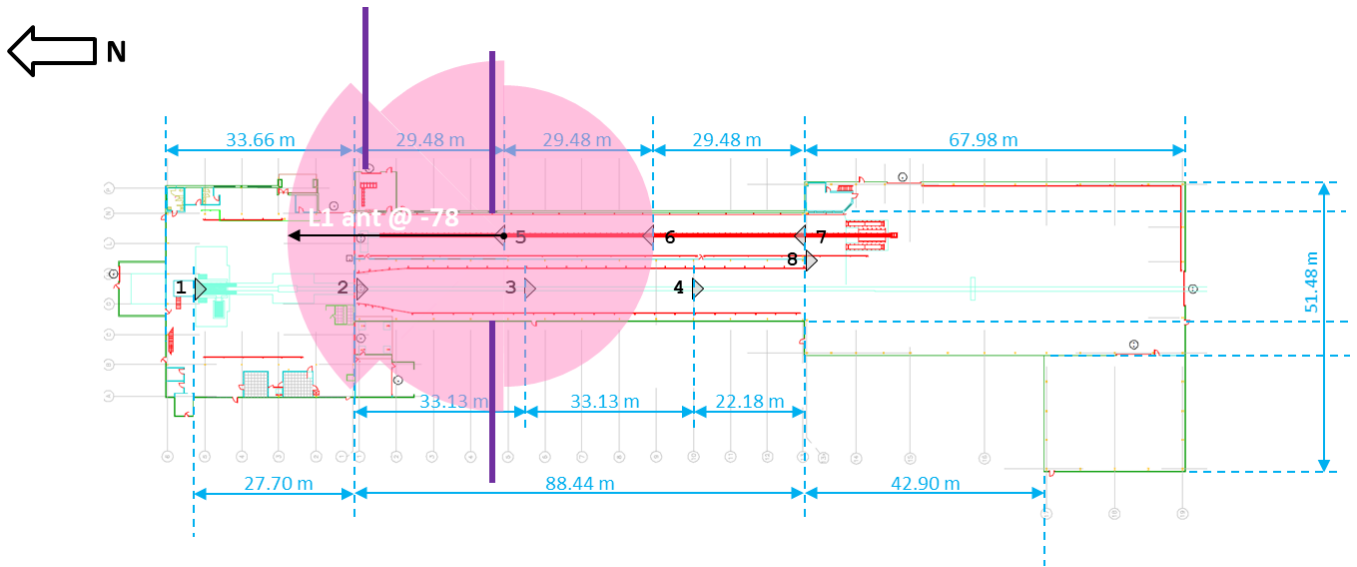

Pink shows area where signal strength is higher than -140 dBm EIRP for **Repeater 6**, set to -78 dBm ERP:

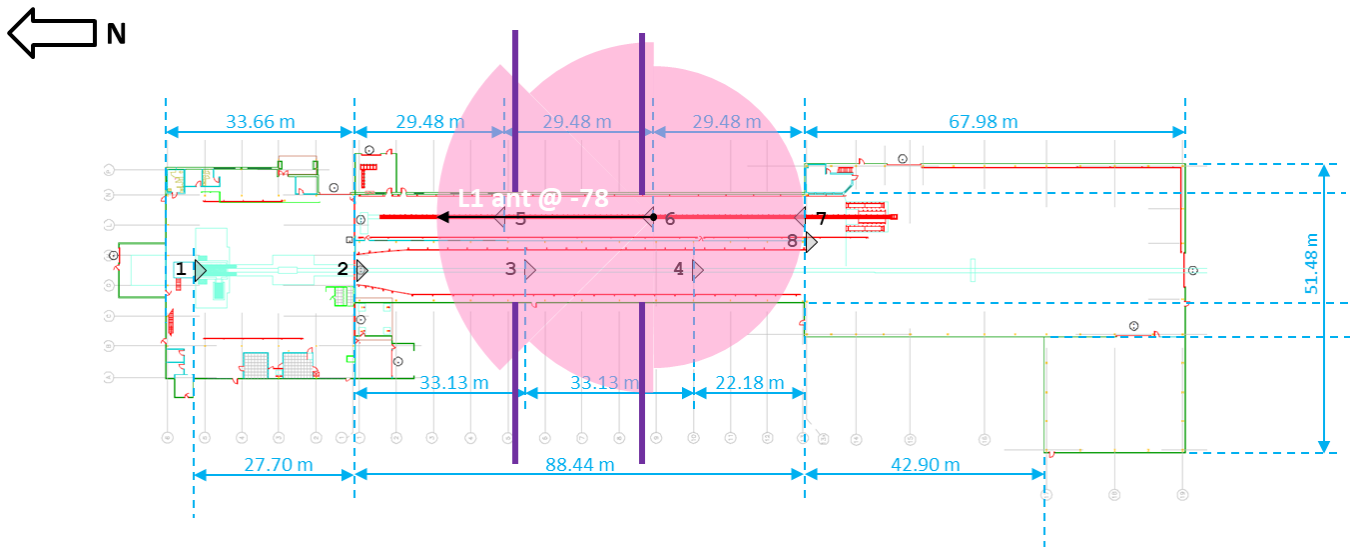

Pink shows area where signal strength is higher than -140 dBm EIRP for **Repeater 7**, set to -78 dBm ERP:

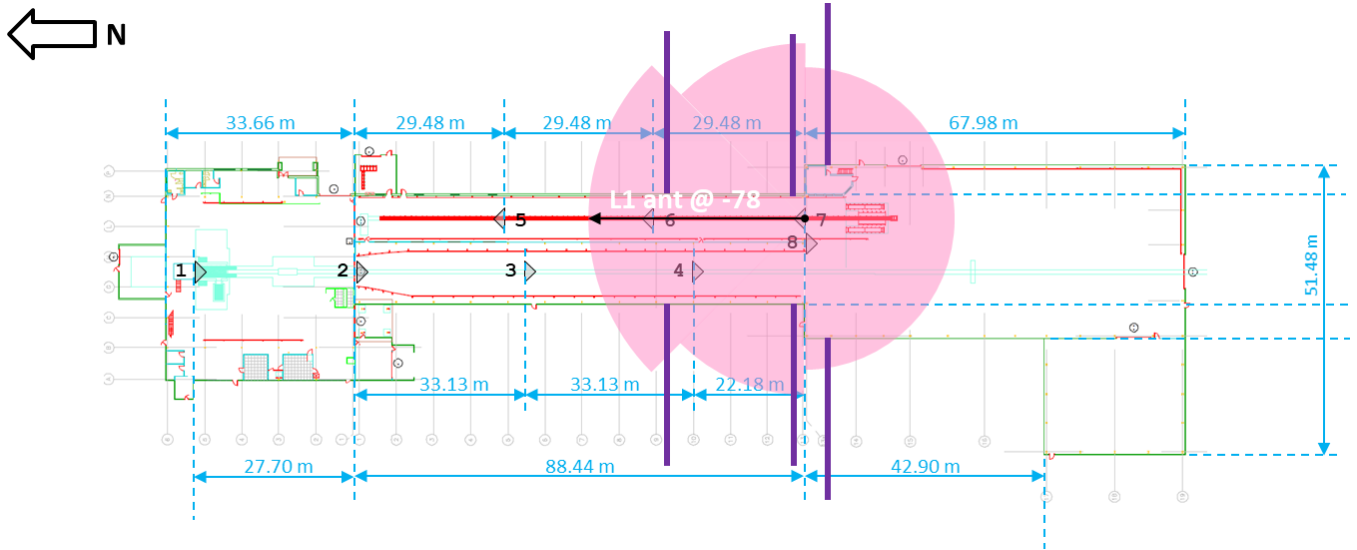

Pink shows area where signal strength is higher than -140 dBm EIRP for **Repeater 8**, set to -77 dBm ERP:

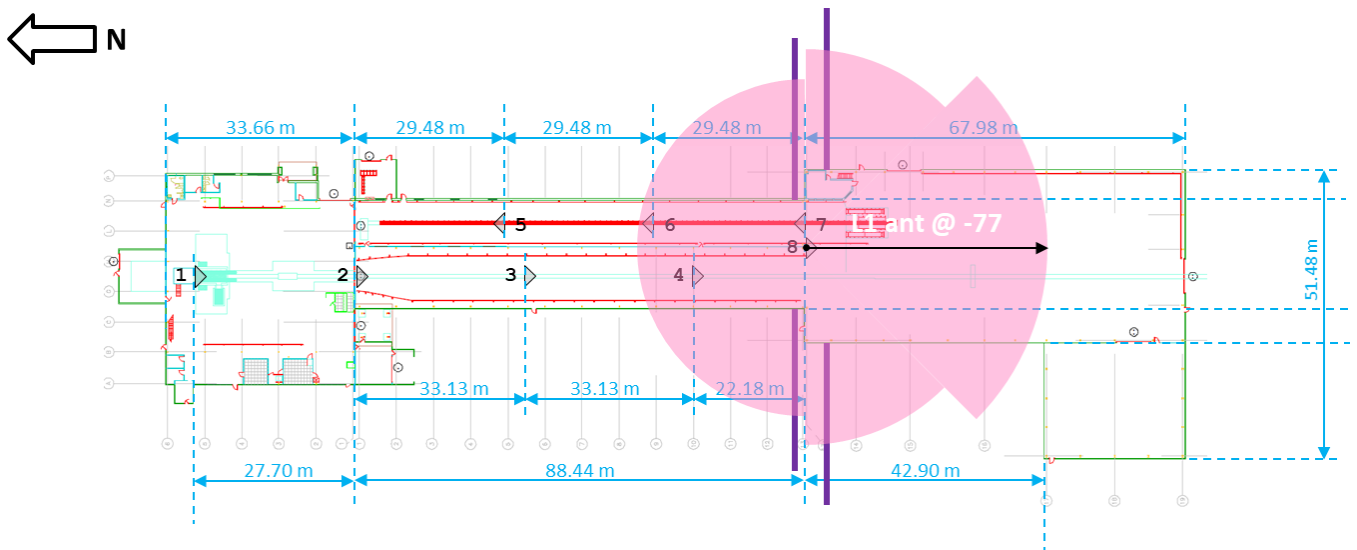

Appendix – Calculations for Signal Strength Depictions

Below are the calculations for how far the signal strength of -140 dBm EIRP (or higher) reaches from the repeater, as a function of azimuth and repeater power setting. The results of these calculations are used in the earlier section “Supplement – Graphical Depictions of Signal Strength”.

Label	Parameter	Value	Units	Notes / Formula
A	Received signal strength of interest	-140	dBm	
B	Frequency of interest	1575.42	MHz	L1 center frequency
C	Transmit ERP from repeater	-79	dBm	Power setting on repeater
D	Transmit EIRP from repeater	-76.85	dBm	= C + 2.15
E	Azimuth range of interest	315-45	degrees	
F	Antenna gain in this azimuth range	4.33	dB	Obtained from "pie slice" depiction of gain shown earlier
G	Transmit EIRP from repeater's antenna	-72.5	dBm	= D + F
H	Distance to which signal strength of interest extends	35.83	meters	= $10^{((-A + G - 20 \cdot \log(B) + 27.55)/20)}$

Label	Parameter	Value	Units	Notes / Formula
A	Received signal strength of interest	-140	dBm	
B	Frequency of interest	1575.42	MHz	L1 center frequency
C	Transmit ERP from repeater	-79	dBm	Power setting on repeater
D	Transmit EIRP from repeater	-76.85	dBm	= C + 2.15
E	Azimuth range of interest	45-90, 270-315	degrees	
F	Antenna gain in this azimuth range	2.50	dB	Obtained from "pie slice" depiction of gain shown earlier
G	Transmit EIRP from repeater's antenna	-74.4	dBm	= D + F
H	Distance to which signal strength of interest extends	29.01	meters	= $10^{((-A + G - 20 \cdot \log(B) + 27.55)/20)}$

Label	Parameter	Value	Units	Notes / Formula
A	Received signal strength of interest	-140	dBm	
B	Frequency of interest	1575.42	MHz	L1 center frequency
C	Transmit ERP from repeater	-79	dBm	Power setting on repeater
D	Transmit EIRP from repeater	-76.85	dBm	= C + 2.15
E	Azimuth range of interest	90-270	degrees	
F	Antenna gain in this azimuth range	1.17	dB	Obtained from "pie slice" depiction of gain shown earlier
G	Transmit EIRP from repeater's antenna	-75.7	dBm	= D + F
H	Distance to which signal strength of interest extends	24.89	meters	= $10^{((-A + G - 20 \cdot \log(B) + 27.55)/20)}$

Label	Parameter	Value	Units	Notes / Formula
A	Received signal strength of interest	-140	dBm	
B	Frequency of interest	1575.42	MHz	L1 center frequency
C	Transmit ERP from repeater	-78	dBm	Power setting on repeater
D	Transmit EIRP from repeater	-75.85	dBm	= C + 2.15
E	Azimuth range of interest	315-45	degrees	
F	Antenna gain in this azimuth range	4.33	dB	Obtained from "pie slice" depiction of gain shown earlier
G	Transmit EIRP from repeater's antenna	-71.5	dBm	= D + F
H	Distance to which signal strength of interest extends	40.20	meters	= $10^{((-A + G - 20 \cdot \log(B) + 27.55)/20)}$

Label	Parameter	Value	Units	Notes / Formula
A	Received signal strength of interest	-140	dBm	
B	Frequency of interest	1575.42	MHz	L1 center frequency
C	Transmit ERP from repeater	-78	dBm	Power setting on repeater
D	Transmit EIRP from repeater	-75.85	dBm	= C + 2.15
E	Azimuth range of interest	45-90, 270-315	degrees	
F	Antenna gain in this azimuth range	2.50	dB	Obtained from "pie slice" depiction of gain shown earlier
G	Transmit EIRP from repeater's antenna	-73.4	dBm	= D + F
H	Distance to which signal strength of interest extends	32.55	meters	= $10^{((-A + G - 20 \cdot \log(B) + 27.55)/20)}$

Label	Parameter	Value	Units	Notes / Formula
A	Received signal strength of interest	-140	dBm	
B	Frequency of interest	1575.42	MHz	L1 center frequency
C	Transmit ERP from repeater	-78	dBm	Power setting on repeater
D	Transmit EIRP from repeater	-75.85	dBm	= C + 2.15
E	Azimuth range of interest	90-270	degrees	
F	Antenna gain in this azimuth range	1.17	dB	Obtained from "pie slice" depiction of gain shown earlier
G	Transmit EIRP from repeater's antenna	-74.7	dBm	= D + F
H	Distance to which signal strength of interest extends	27.92	meters	= $10^{((-A + G - 20 \cdot \log(B) + 27.55)/20)}$

Label	Parameter	Value	Units	Notes / Formula
A	Received signal strength of interest	-140	dBm	
B	Frequency of interest	1575.42	MHz	L1 center frequency
C	Transmit ERP from repeater	-77	dBm	Power setting on repeater
D	Transmit EIRP from repeater	-74.85	dBm	= C + 2.15
E	Azimuth range of interest	315-45	degrees	
F	Antenna gain in this azimuth range	4.33	dB	Obtained from "pie slice" depiction of gain shown earlier
G	Transmit EIRP from repeater's antenna	-70.5	dBm	= D + F
H	Distance to which signal strength of interest extends	45.11	meters	= $10^{((-A + G - 20 \cdot \log(B) + 27.55)/20)}$

Label	Parameter	Value	Units	Notes / Formula
A	Received signal strength of interest	-140	dBm	
B	Frequency of interest	1575.42	MHz	L1 center frequency
C	Transmit ERP from repeater	-77	dBm	Power setting on repeater
D	Transmit EIRP from repeater	-74.85	dBm	= C + 2.15
E	Azimuth range of interest	45-90, 270-315	degrees	
F	Antenna gain in this azimuth range	2.50	dB	Obtained from "pie slice" depiction of gain shown earlier
G	Transmit EIRP from repeater's antenna	-72.4	dBm	= D + F
H	Distance to which signal strength of interest extends	36.53	meters	= $10^{((-A + G - 20 \cdot \log(B) + 27.55)/20)}$

Label	Parameter	Value	Units	Notes / Formula
A	Received signal strength of interest	-140	dBm	
B	Frequency of interest	1575.42	MHz	L1 center frequency
C	Transmit ERP from repeater	-77	dBm	Power setting on repeater
D	Transmit EIRP from repeater	-74.85	dBm	= C + 2.15
E	Azimuth range of interest	90-270	degrees	
F	Antenna gain in this azimuth range	1.17	dB	Obtained from "pie slice" depiction of gain shown earlier
G	Transmit EIRP from repeater's antenna	-73.7	dBm	= D + F
H	Distance to which signal strength of interest extends	31.33	meters	= $10^{((-A + G - 20 \cdot \log(B) + 27.55)/20)}$

Label	Parameter	Value	Units	Notes / Formula
A	Received signal strength of interest	-140	dBm	
B	Frequency of interest	1575.42	MHz	L1 center frequency
C	Transmit ERP from repeater	-76	dBm	Power setting on repeater
D	Transmit EIRP from repeater	-73.85	dBm	= C + 2.15
E	Azimuth range of interest	315-45	degrees	
F	Antenna gain in this azimuth range	4.33	dB	Obtained from "pie slice" depiction of gain shown earlier
G	Transmit EIRP from repeater's antenna	-69.5	dBm	= D + F
H	Distance to which signal strength of interest extends	50.61	meters	= $10^{((-A + G - 20 \cdot \log(B) + 27.55)/20)}$

Label	Parameter	Value	Units	Notes / Formula
A	Received signal strength of interest	-140	dBm	
B	Frequency of interest	1575.42	MHz	L1 center frequency
C	Transmit ERP from repeater	-76	dBm	Power setting on repeater
D	Transmit EIRP from repeater	-73.85	dBm	= C + 2.15
E	Azimuth range of interest	45-90, 270-315	degrees	
F	Antenna gain in this azimuth range	2.50	dB	Obtained from "pie slice" depiction of gain shown earlier
G	Transmit EIRP from repeater's antenna	-71.4	dBm	= D + F
H	Distance to which signal strength of interest extends	40.98	meters	= $10^{((-A + G - 20 \cdot \log(B) + 27.55)/20)}$

Label	Parameter	Value	Units	Notes / Formula
A	Received signal strength of interest	-140	dBm	
B	Frequency of interest	1575.42	MHz	L1 center frequency
C	Transmit ERP from repeater	-76	dBm	Power setting on repeater
D	Transmit EIRP from repeater	-73.85	dBm	= C + 2.15
E	Azimuth range of interest	90-270	degrees	
F	Antenna gain in this azimuth range	1.17	dB	Obtained from "pie slice" depiction of gain shown earlier
G	Transmit EIRP from repeater's antenna	-72.7	dBm	= D + F
H	Distance to which signal strength of interest extends	35.15	meters	= $10^{((-A + G - 20 \cdot \log(B) + 27.55)/20)}$

The following two pages discuss the GLI-Metro-G specifications for transmission of GPS and GLONASS



GLI-METRO-G

KEY FEATURES

- » Precise control over output signal level
- » High Frequency Selectivity - Passes GPS, GLONASS & GALILEO frequencies while rejecting other out-of-band signals.
- » Continuous Built-In-Testing (BIT)
- » Automatic Oscillation Detection
- » Perfect for aircraft hangars, manufacturing test cells, R&D facilities, any automated test environment or an anechoic chamber
- » Use for any GNSS retransmission application

OPTIONS

- » Waterproof
- » L1 Only vs. L1/L2 Filtering
- » Multiple Connector Types
- » Power Always ON or Power ON/OFF



GLI-Metro-G

INTRODUCTION

The GLI-METRO-G is a GNSS* smart amplifier, perfect for the commercial and public sector. When used in conjunction with an active GPS/GLONASS receive antenna, it will pass GPS+GLONASS signals inside a building, hangar or any structure where signal is not accessible. It can be used in an automated test environment or in a shielded room that needs GNSS signal.

GLI-METRO-G has the unique benefit of allowing selection for the power control between signals. A user can easily decide which signal output the GLI-METRO-G will use to control signal power: GPS+GLONASS, GLONASS only or GPS only. This reduces the need for multiple antennas, receive devices and multiple antenna runs, while lowering maintenance and installation costs.

AUTOMATIC SIGNAL LEVEL CONTROL

The GLI-METRO-G employs an automatic control to maintain the set output signal level, regardless of the uncertain loss or gain in the receive antenna cable network. Derived from high performance systems for military applications, this device allows precise determination over effective radiated power (ERP) levels, regardless of the uncertain loss or gain in the receive antenna cable network. It will automatically condition the signal and prevent changes in performance.

BUILT-IN TROUBLESHOOTING

The GLI-METRO-G will identify and isolate the following:

- | | |
|-------------------------|--|
| - Oscillation condition | - Internal component failure |
| - High gain | - Less than four satellites |
| - Low gain | - No satellites with adequate signal |
| - Short/Open circuit | (call for complete list of conditions) |

**GLI-Metro-G offers support for present and future GNSS signals, including Galileo, ensuring operation with future devices.*

www.gpssource.com



GPS Source, Inc. | techsales@gpssource.com | (866) 289-4777 toll free (in U.S.) | +1 (719) 561-9520

AS9100 Rev C and ISO 9001 Certified

GLI-Metro-G

GLI-METRO-G 1X1

GLI-METRO-G OUTPUT PORTS

- » Number of ports 1

GLI-METRO-G ELECTRICAL SPECIFICATIONS

- » Input/Output impedance 50Ω
- » SWR all ports (typical)
 - Input: 2:1
 - Output: 2:1
- » Bandwidth
 - GPS & GLONASS L1 1560-1615 MHz
 - GPS & GLONASS L1/L2 1170 - 1310 MHz
- » Gain (nominal) 33 dB
- » Gain Range 0-55dB
- » Gain flatness <3 dB
- » Noise figure <3 dB
- » AC input level
 - 110 VAC
 - 230VAC UK
 - 230VAC European
- » DC input level 16 - 28 VDC
- » Active Antenna Output Power Supply Output 6.8V

GLI-METRO-G PHYSICAL SPECIFICATIONS

- » RF connectors
 - N (m, f)
 - SMA (m, f)
 - TNC (m, f)
 - SMB (f)
 - SMC (f)
- » RS232 serial connector DB9(F) DCE
- » Weight:
 - 1x1 1.2 lbs (544.3 g)
- » Size:
 - 1x1 6.4" x 3.9" x 2.0"
 - (162.6 mm x 99 mm x 50.8 mm)
- » Operating temperature -40 to +85°C

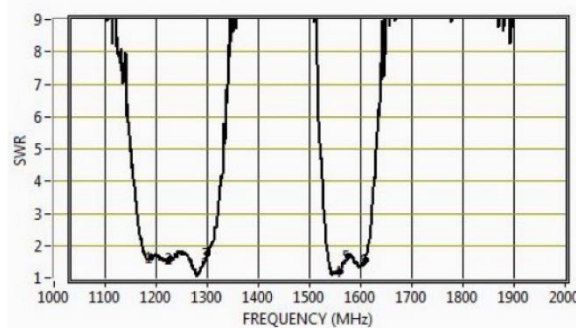
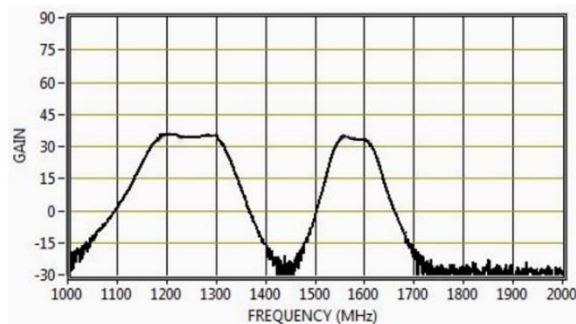
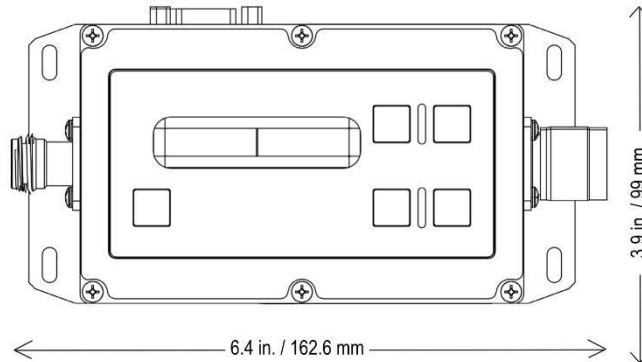

AS9100 & ISO 9001:2008 Certified
 Veteran Owned Small Business
 CCR Registered
 CAGE: 1RTJ5
 DUNS: 883995677
 NAICS: 334220, 334290, 334511,
 541330, 541690

www.gpssource.com

