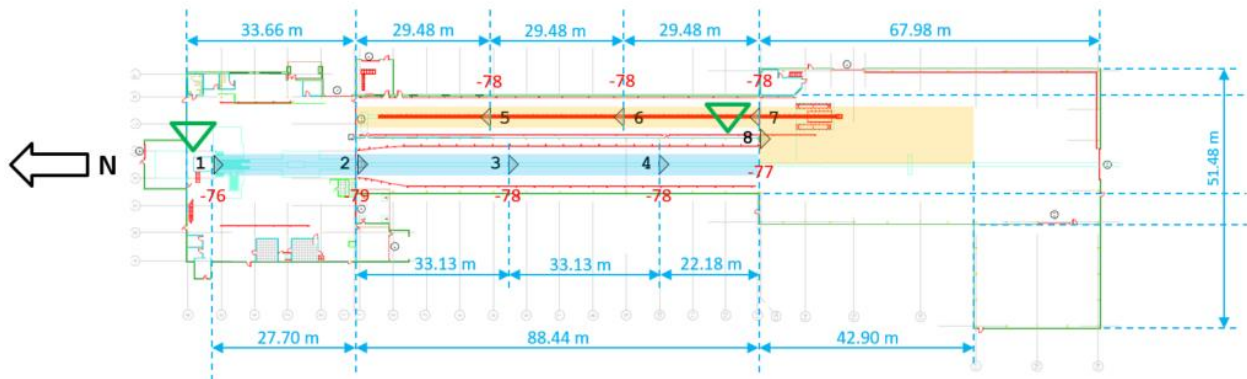

Exhibit #3

Directional Location of Re-Radiation Equipment

The GLI-Metro-G repeater (more specifically the passive transmitting antenna attached to the repeater) is directional.

Below is the system diagram of the crash test facility with the proposed GPS repeater locations. Repeater 1 is existing and is already included in the license. GMRC proposes to add Repeaters 2, 3, 4, 5, 6, 7, and 8.



Legend:

- = Rooftop antenna (outdoors)
- = Areas requiring coverage
- = GNSS repeater (with attached antenna)¹
- = Repeater power setting (dBm ERP)

The following table provides information about the directionality and orientation of each of the repeaters shown above.

Repeater	Width of Beam in Degrees at the Half Power Point	Orientation in Horizontal Plane (degrees from North)	Orientation in Vertical Plane (degrees from horizontal)
1	75 +/-5 at -3dB from Peak (Free Space)	180	0-45 below horizontal
2	75 +/-5 at -3dB from Peak (Free Space)	180	0-45 below horizontal
3	75 +/-5 at -3dB from Peak (Free Space)	180	0-45 below horizontal
4	75 +/-5 at -3dB from Peak (Free Space)	180	0-45 below horizontal
5	75 +/-5 at -3dB from Peak (Free Space)	0	0-45 below horizontal
6	75 +/-5 at -3dB from Peak (Free Space)	0	0-45 below horizontal
7	75 +/-5 at -3dB from Peak (Free Space)	0	0-45 below horizontal
8	75 +/-5 at -3dB from Peak (Free Space)	180	0-45 below horizontal