

EXTENT™ P5622

Tri-Sector Pseudo Omni Outdoor Antenna

[698-960, 1710-2700 MHz]

DESCRIPTION:

Broadband cross-polarized tri-sector pseudo omni antenna with internal combiners.

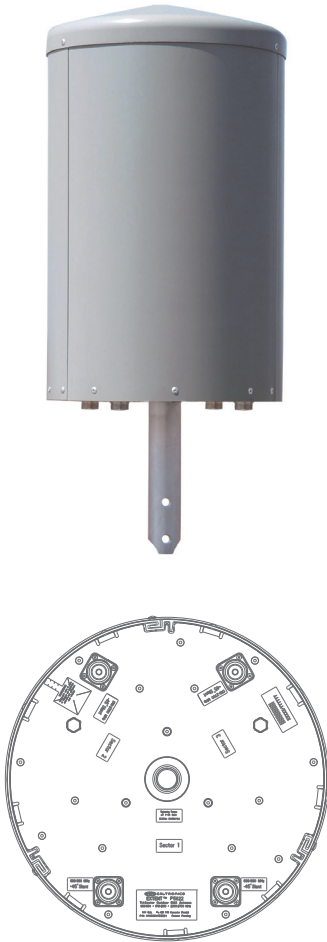

Electrical Specifications							
Frequency Band [MHz]	698-824	824-894	894-960	1710-1900	1900-2180	2300-2360	2360-2700
Polarization	Dual slant 45° (±45°)						
Antenna Structure	Tri-Sector with internal combiner (Pseudo Omni)						
Input	4x 7/16 DIN female - Bottom						
VSWR	<1.7:1		<1.7:1			<1.7:1	
Impedance	50 Ω						
Gain - Omni Mode**	6 dBi	7 dBi	7 dBi	8 dBi	8 dBi	8 dBi	8 dBi
Gain / Sector (±1dBi)	10 dBi	11 dBi	11 dBi	12 dBi	12 dBi	12 dBi	11.5 dBi
In-Band Isolation between Ports	< -25 dB Typical						
Inter-Band Isolation between Ports	< -35 dB Typical						
Elevation HPBW	40°	35°	33°	19°	18°	16°	15°
Azimuth	Omni (360°)						
Cross-Pol φ < HPBW	< 16 dB						
Cross-Pol φ > HPBW	< 10 dB						
Max. Input Power per Port	250 Watts			200 Watts			
Downfill	0° fixed						
Ripple (typ.)	7 dB			10 dB			
PIM @ 2 x 43 dBm per Port	< -150 dBc						

** Omni mode gain includes combiner losses.

Mechanical Specifications

Operating Temperature	-40 to 158°F (-40 to +70°C)
Antenna Weight	28.9 lbs (13.1 kg)
Antenna Diameter	14.5" (370mm)
Antenna Height (without connectors)	24" (611mm)
Ingress Protection	IP65
Antenna Radome Color	Utility grey or brown, custom colors possible
Antenna Wind survival Rating	150 mph (240 kph)

PATTERNS

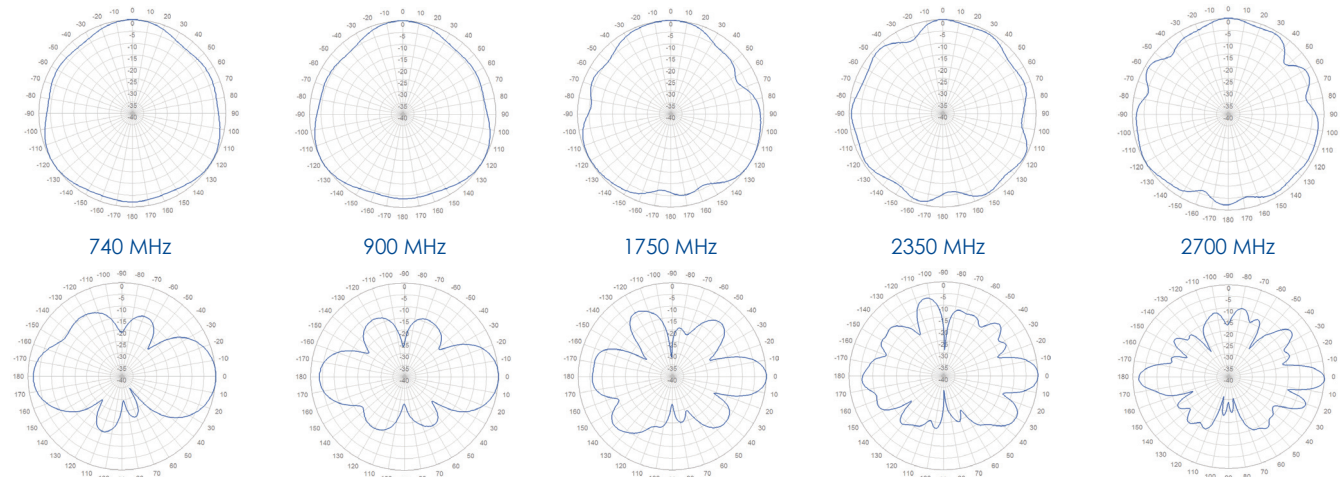

MOUNTING INTERFACE & ANTENNA OPTIONS:

Part Number	Radome Color	Mounting Interface:
04119261-05818-1	Grey	1" Threaded Bolt (see below drawings, Option 1)
04119261-05818-6	Brown	1" Threaded Bolt (see below drawings, Option 1)
04119261-05818	Grey	13" Center Rod (see below drawings, Option 2)
04119261-05818-5	Brown	13" Center Rod (see below drawings, Option 2)

MECHANICAL DRAWINGS & MOUNTING INTERFACE OPTIONS :
**OPTION 1
1" THREADED BOLT**

Mounting Hardware included
(1" nut, washer, spring washer and split cotter pin)

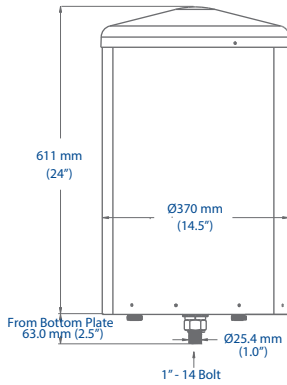
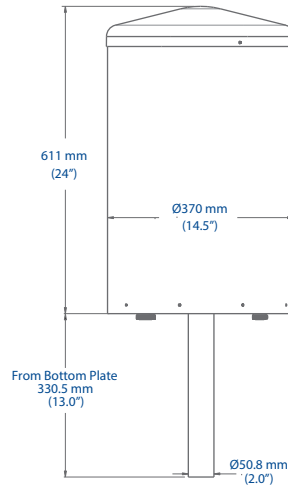
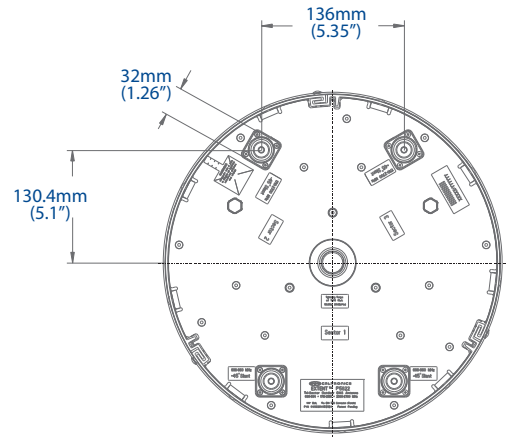
**OPTION 2
13" CENTER ROD**

OPTION 1 & 2 - Bottom View

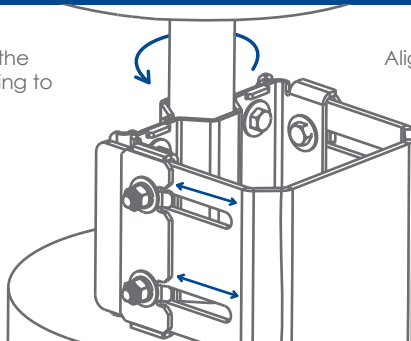
Galtronics Mounting Kit for pole top installations (Option 2)

Rotate and lock the antenna according to the needs of the network.



Align the antenna to the center of the pole for optimal stability.

MOUNTING INFORMATION:
Option 1:

The antenna can be mounted using the 1"-14 bolt and the provided hardware (1" nut, washer, spring washer and split cotter pin). Third party mounting fixtures are available. More information can be provided on inquiry.

Option 2:

The antenna can be mounted on the top of an utility pole using the optional Galtronics pole mounting bracket suitable for poles from 6" to 13" diameter (see below).

