

COMPLIANCE TESTING EXPERIMENTAL RADIO LICENSE REQUEST - ASPIRE 350 IRIDIUM SATCOM

EMS Technologies Canada, Ltd.

INITIAL RELEASE DATE: 03/2021

Ottawa, Canada

Table of Contents

1	INTRODUCTION	3
1.1	PURPOSE	3
1.2	PRE-CONDITIONS FOR OTA TESTING	3
2	PRODUCT AND SYSTEM DESCRIPTION	5
2.1	GENERAL	5
2.2	SYSTEM OVERVIEW	5
2.3	SYSTEM CAPABILITIES	7
2.4	FREQUENCY BAND OF OPERATION	7
2.5	RF CARRIER TYPES USED	7
2.6	ANTENNA TYPES USED	9
2.6.1	<i>LGA Antenna from Aero Antenna Technology</i>	9
2.6.2	<i>HGA Antenna from Aero Antenna Technology</i>	9
2.6.3	<i>Antenna Separation Requirements</i>	10
2.6.4	<i>Safety Considerations</i>	10
3	FORMAL REQUEST FOR DEVELOPMENTAL LICENSE	12
APPENDIX A	LGA DUAL PATCH DATA SHEET	13
APPENDIX B	LGA IRIDIUM CERTIFICATION LETTER	14
APPENDIX C	ACRONYMS	15

1 Introduction

This detailed exhibit is prepared by EMS Technologies Canada Ltd, a wholly owned subsidiary of Honeywell International Inc, to request a compliance testing experimental radio license from the FCC to conduct over-the-air testing in the Iridium L-band frequency band to demonstrate compliance to the Iridium certification over-the-air testing.

This detailed exhibit describes the over-the-air testing to be executed with the Aspire 350 Iridium SATCOM to demonstrate compliance to the certification requirements of the Iridium Satellite network system using the L-band, as specified in the Iridium Certification Guideline for the Legacy and Certus service over the Iridium Next Generation Satellite constellation.

Aspire 350 Iridium product certification testing will be conducted at 1750 Tyson Boulevard, Suite 1400, McLean, VA 22102, USA.

Aspire 350 flight testing will be conducted at the Honeywell flight test site in Deer Valley, Phoenix, Arizona, USA.

1.1 Purpose

This detailed exhibit is prepared for the sole reason of requesting a compliance testing experimental radio license from the FCC, pursuant to CFR Title 47, Part 5, Subpart G, for a period running from May 2021 to May 2022 to conduct OTA tests with the Aspire 350 Iridium SATCOM system for purposes of demonstrating compliance to the certification requirements of the Iridium Satellite network in the L-band. As per CFR Title 47, Part 5, subpart 5.505, compliance testing experimental licenses are exempt from complying with the station identification requirements of subpart 5.115.

1.2 Pre-Conditions for OTA Testing

Prior to executing over-the-air testing, EMS Technologies Canada Inc will conduct Iridium Physical Layer tests as well as in-house radio regulatory testing to show compliance to the following regulatory standards:

FCC, CFR Title 47 – Telecommunications:

FCC CFR Title 47, Part 15 and 25	FCC part 2 CFR 47 General Rules and Regulation
Conducted Limits (FCC CFR Title 47, Part 15.107 (b))	
Radiated Emissions Limits – Class A Digital Device (FCC CFR Title 47, Part 25, Subpart 109b)	Subpart 2.1053 – Measurements required: Field Strength of spurious radiation

Frequencies and frequency tolerance (FCC CFR Title 47, Part 25, Subpart 202)	Subpart 2.1055 a-1 Frequency Stability with temperature variation Subpart 2.1055 d-1 Frequency Stability with primary power variation:
Emissions limits (FCC CFR Title 47, Part 25, Subpart 202 f-3)	Subpart 2.1051 Measurement required: Spurious emissions at antenna terminal
Emissions limits (FCC CFR Title 47, Part 25, Subpart 202 f-1,2)	2.1049 (h) Measurement required: Occupied bandwidth
Limits on Emissions from Mobile Earth Stations for Protection of Aeronautical Radio Navigation-Satellite Service (FCC CFR Title, 47 Part 25, Subpart 216)	Subpart 2.1051 Measurement required: Spurious emissions at antenna terminal

The in-house test results will be submitted to Iridium LLC for their review. Over-the-Air testing will be conducted only when Iridium approves the test results and deems that Aspire 350 Satcom is fit to operate in the Iridium Satellite network without causing any harm to other communications equipment operating in the Iridium frequency band as well as to other radio communication equipment operating outside the Iridium frequency band.

2 Product and System Description

2.1 General

This section describes the Aspire 350 AES Satcom System and its service capabilities for the aeronautical application over the Next Gen Iridium Satellite constellation.

2.2 System Overview

This section describes the Aspire 350 AES Satcom System, services and typical operation and installation environments. The SATCOM avionics is an integral part of the complete L-Band Iridium Satellite Communication System and comprises of the following components.

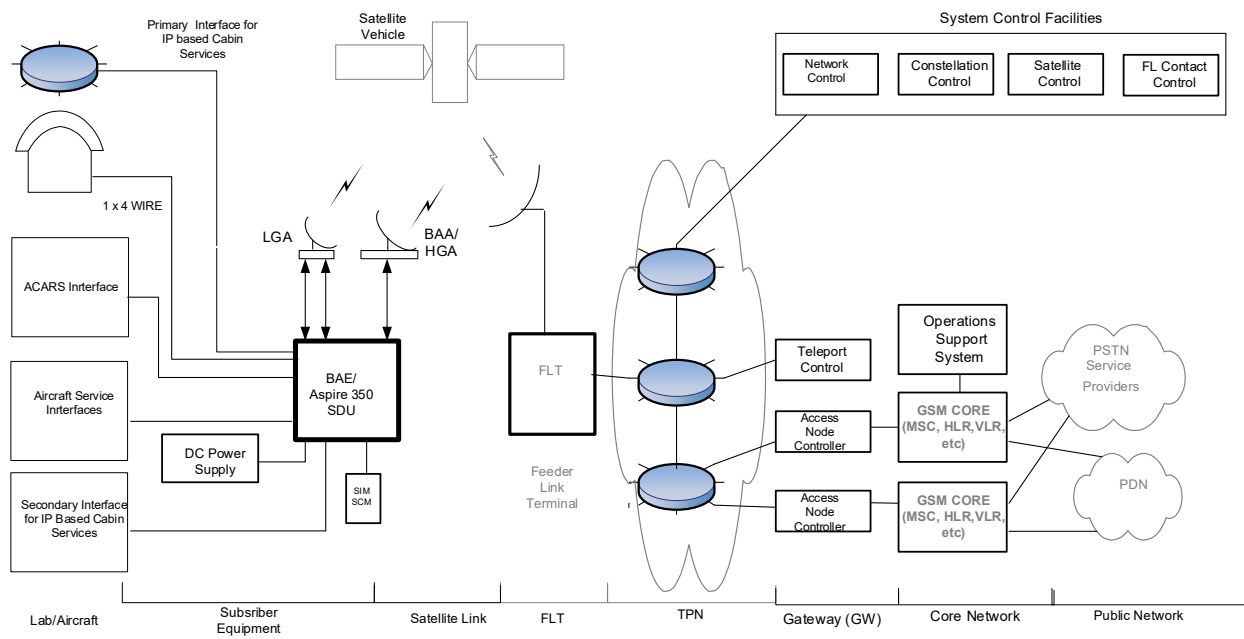

Figure 1: Aspire 350 System Overview

- Satellite Data Unit (SDU)
- SDU Configuration Module (SCM)
- LGA – Low Gain Antenna (Passive Dual Puck Antenna)
- HGA/BAA – High Gain Antenna/Broadband Active Antenna (Contains HPA and LNA)
- Associated wiring

The SDU is the central communications processing and control unit, largely determining the functionality of the complete SATCOM system. The signal in space parameters are determined by the SDU in relation to modulation/demodulation, error correction, coding, interleaving and data rates associated with the communication channels. The SDU contains circuits for conversion of digital and/or analog inputs/outputs to/from radio frequency (RF). The SDU requires antenna functions and external amplifiers to complete the SATCOM avionics suite. The SDU is capable of sending and receiving various data rates. The data rate is selected by the individual applications and by pragmatic assessment of current operating conditions.

The external SCM contains the Secure Owner Requirements Table (ORT), the User Owner Requirements Table (ORT) and two Subscriber Identity Module (SIM).

The Broadband Active Antenna (BAA) or High Gain Antenna (HGA) contains the Tx High Power amplifier (HPA), Rx Low Noise Amplifier (LNA) , a band pass filter and radiating elements to transfer RF signal into electromagnetic fields for transmission to the SV and reception of RF signals from SV. The BAA antenna will be interfaced with the HCM modem for Certus Services.

The LGA antenna is a passive dual patch omni-directional antenna which is interfaced to the two LBT modems for safety services.

The Aspire 350 AES is aeronautical communications unit which operates over the Iridium L- Band of 1618 MHz to 1626 MHz. The maximum EIRP output from the HGA antenna is 15.2 dBW EIRP per carrier with maximum antenna gain of 8dBic. The HGA antenna provides cabin data services using the Iridium BCX9810A modem. The LGA antenna is used for cockpit voice and ACARS services using the Iridium LBT 9523N modem. The maximum output from the LGA antenna is 6.4dBW EIRP. The LGA is an omni directional antenna while the HGA is a directional antenna.

Honeywell is developing Aspire 350 AES for aeronautical communications services in the L-Band and part of the development phase includes conducting Over-The-Air compliance testing in the USA, after conducting emissions testing as per FCC CFR 47, Subpart 25 and 15 and Iridium’s approval of the test results.

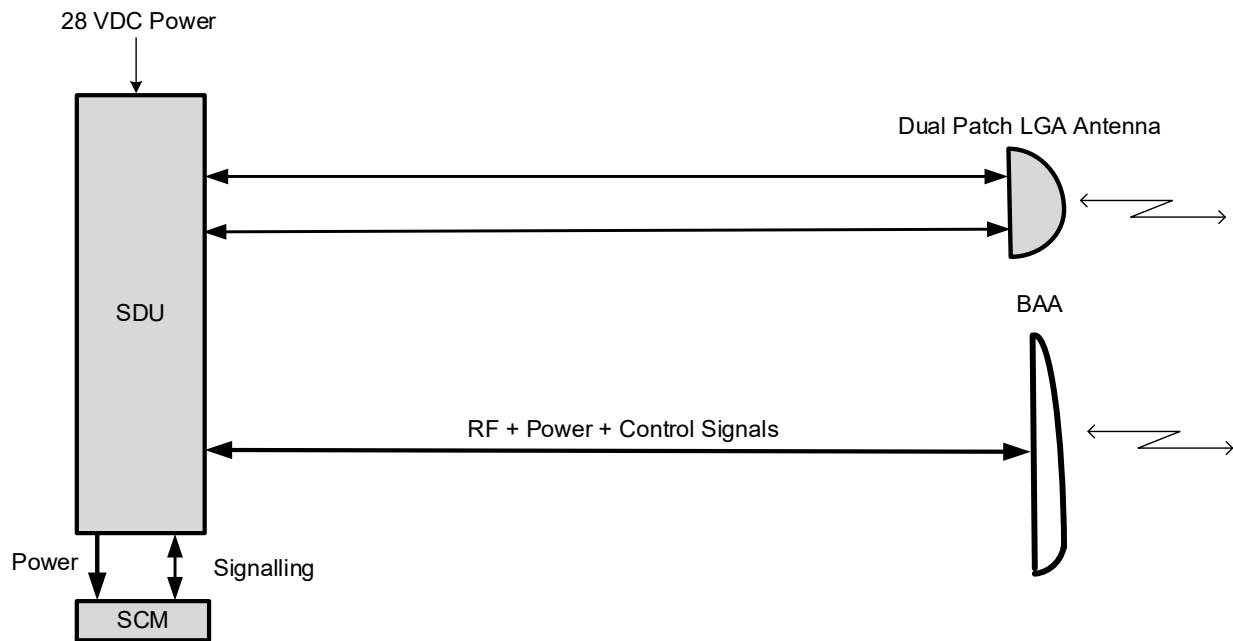

Figure 2: Aspire 350 AES System Configuration with LGA and HGA antennas

2.3 System Capabilities

The Aspire 350 AES Satcom terminal will support the following services:

Cockpit Services

ACARS
1 Safety voice channel

Interface

ARINC 429 CMU
4-Wire interface

Cabin Services

IP Background Services
IP Streaming Services
VoIP Services

Interface

Ethernet for Cabin Services
Ethernet for Cabin Services
Ethernet for Cabin Services

2.4 Frequency Band of Operation

Aspire 350 is an aeronautical mobile earth station that operates in the L-Band Iridium frequency band to provide cockpit voice and ACARS data communication as well as cabin data services using the Iridium Next Generation Satellite constellation. Aspire 350 uses two legacy LBT 9523N modems from Iridium to provide the cockpit voice and data services. It also uses a BCX 9810A modem to provide cabin data services. It uses a hybrid of FDMA and TDMA modes for communication with the LEO Iridium satellite constellation.

Transmit frequency band is between 1618.0 MHz to 1626.0 MHz.

Receiver frequency band is between 1618.0 MHz to 1626.5 MHz.

During over-the-air testing, the carrier transmit frequency of the constituent modems is assigned by the Iridium Satellite Network and Iridium LLC controls and manages the Iridium Satellite Network.

2.5 RF Carrier Types Used

Aspire 350 uses the following RF carriers to provide cockpit voice and ACARS data services:

Table 1: RF Characteristics of the Safety Services provided by Iridium LBT 9523N Modems

Modulation Type	Carrier Type	Antenna Gain in dBic	Maximum EIRP in dBW	Symbol Rate (ksps)	Authorized BW (kHz)
De-QPSK	B1	3	6.4	25	41.67
De-QPSK	B1	3	6.4	25	41.67

Aspire 350 uses the following RF carriers to provide cabin data services:

Table 2: RF characteristics of the Certus Service provided by the BCX 9810A Iridium Modem

Modulation Type	Carrier Type	Max Antenna Gain in dBic	Maximum EIRP in dBW	Symbol Rate (ksps)	Authorized BW (kHz)
QPSK	B1	8	9.0	25	41.67
QPSK	C1	8	5.0	30	41.67
QPSK	C2	8	6.0	60	83.33
QPSK	C8 QPSK	8	9.0	240	333.3
QPSK	2C8 QPSK	8	12.0	480	666.6
16APSK	C8 16APSK	8	15.2	240	333.3
16APSK	2C8 16APSK	8	18.2	480	666.6

Table 3: Particulars of Operation

Lower Freq. (MHz)	Upper Freq (MHz)	Carrier Type	Input Power (milliWatts) ¹	ERP (Watts) ²	Mean/Peak	Freq. Tolerance %	Station Class
1618	1626	B1	1330.4	2.7	Mean	0.0021	Fixed and Mobile
1618	1626	B1	1.0	4.8	Mean	0.0021	Fixed and Mobile
1618	1626	C1	1.0	1.9	Mean	0.0021	Fixed and Mobile
1618	1626	C2	1.0	2.4	Mean	0.0021	Fixed and Mobile
1618	1626	C8 QPSK	1.0	4.8	Mean	0.0021	Fixed and Mobile
1618	1626	2C8 QPSK	1.0	9.7	Mean	0.0021	Fixed and Mobile
1618	1626	C8 16APSK	1.0	20.2	Mean	0.0021	Fixed and Mobile
1618	1626	2C8 16APSK	1.0	40.4	Mean	0.0021	Fixed and Mobile

Note 1: Defined as the nominal mean power input from the BCX9810A modem to the HGA for Cabin services and as the nominal mean power input from the LBT 9523N modem to the LGA.

Note 2: ERP (dBW) = EIRP (dBW) – 2.15 dB

Table 4: Emission Data

Carrier Type	Emission Designator	Modulating Signal	Necessary BW (kHz)
B1	41K7Q7W	25,000	41.7
C1	41K7Q7W	30,000	41.7
C2	83KQ7W	60,000	83.3
C8 QPSK	333KQ7W	240,000	333.33
2C8 QPSK	666KQ7W	480,000	666.67
C8 16APSK	333KD7W	240,000	333.33
2C8 16APSK	333KD7W	480,000	666.67

Table 5: Waveforms, Number of Carriers Supported and Types of antennas used

Waveform	Modulation Scheme	Antenna Type	Number of Carriers
B1 (Block 1)	DeQPSK	LGA	1
B1 (Block 1)	DeQPSK	HGA	1
C1 (NEXT)	QPSK	HGA	1
C2 (NEXT)	QPSK	HGA	1
1 C8	QPSK	HGA	1
2 C8	QPSK	HGA	2
1 C8	16APSK	HGA	1
2 C8	16APSK	HGA	2

2.6 Antenna Types Used

2.6.1 LGA Antenna from Aero Antenna Technology

The two Iridium LBT 9523N modems will connect to a dual patch LGA antenna from Aero Antenna Technologies, with part number AT1621-23. The RF path from each LBT modem will pass through a band pass filter, which will provide enough rejection to provide protection of the GNSS band. The LGA antenna used is FAA TSO C-159a approved antenna for installation on all aircrafts including Air Transport, Business Jets, Military and General Aviation airframes. It is also an Iridium approved antenna for operation in the Iridium L-band. The coax cable used to connect the SDU to the LGA antenna will have a maximum of 2.5dB cable loss. The LGA antenna has a maximum of 3.1 dBic gain at 90° elevation angle. A data sheet and Iridium Certificate of the LGA antenna are attached in Appendix A and Appendix B respectively.

2.6.2 HGA Antenna from Aero Antenna Technology

The Iridium designed BCX 9810A modem for cabin services uses a steerable phased array HGA (High Gain Antenna) antenna whose RHCP radiation pattern is controlled via an antenna pointing vector (APV) list for optimum signal reception. The minimum beam width of the 18 APV beams, defined as the width of the -3dBc points from the boresight, is 50°. The antenna gain varies as a function of elevation and azimuth angle and has a maximum of 8dBic and a minimum of 2dBic gain.

The HGA antenna includes an HPA on the transmit side for signal amplification to achieve the required EIRP power as described in Figure 2. It also includes an LNA on the receive RF path for receive signal amplification and proper signal demodulation.

The physical description of the HGA antenna is included below.

The HGA has the following physical characteristics. Some key elements are listed below

Unit Assembly, BAA, P/N 90406851

Dimensions: ref: 4.34"W x 2.9"H x 9.1"L

Weight: 0.7 lbs Max

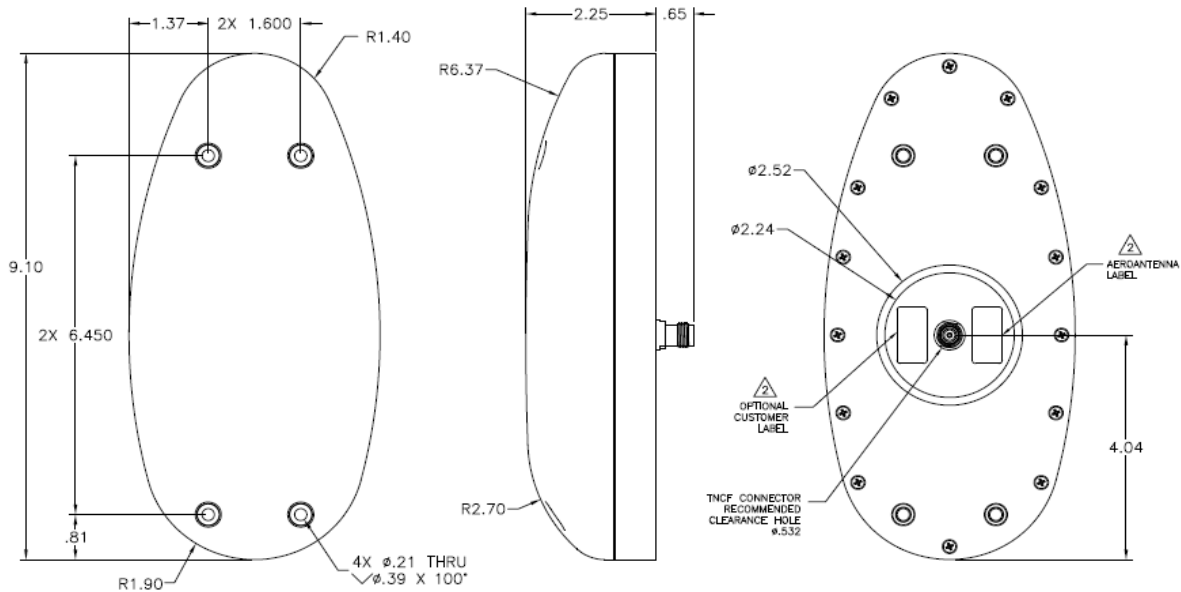

2.6.3 Antenna Separation Requirements

The LGA and HGA antennas will be installed on the fuselage of an aircraft with a minimum separation of 2 meters to prevent a rare occurrence of interference between the two transceivers.

2.6.4 Safety Considerations

The LGA and HGA antennas will be installed on the roof top of a building during certification testing and on the fuselage of an aircraft during flight testing with the body of the aircraft as the ground plane for the antenna. Antennas will be pointing to the Iridium Satellites and no individual will be allowed to be on the boresight of the antenna radiation nor come close to the antenna sites when in operation. All safety precautions will be taken to avoid RF exposure to any human being during testing.

2.7 Tests To Be Executed OTA

The following cock-pit voice and ACARS data services tests are planned to be executed OTA:

Test Type	Configuration	Type of Test	Target completion Rate (%)	Minimum Required Completion Rate (%)
LBT in Voice Mode	SDU to Iridium	2000 calls at 45 Seconds call duration	98	95
		800 calls at 180 Seconds call duration	97	93
		300 calls at 600 Seconds call duration	90	80
LBT in SBD Mode	Mobile Originated MO	1000 340 byte Messages call duration	98	95
	Mobile Terminated MT	1000 270 byte Messages call duration	99	96

The following cabin service VoIP and data services tests are planned to be executed OTA

On-Air Static KPI Testing Performed OTA	Purpose
2000 Voice Calls with 45 seconds call duration	To verify product can access Iridium's network
800 Voice Calls with 180 seconds call duration	Benchmark metric as well as intra-beam hand-offs
300 Voice Calls with 600 seconds call duration	To verify inter satellite hand-offs and link margins
200 FTP Uploads of a 5MBytes data file	FTP server at TSC and 5MByte file will be provided by Iridium
200 FTP Downloads of a 10MBytes data file	FTP server at TSC and 10MByte file will be provided by Iridium

3 Formal Request for Compliance Testing Experimental Radio License

EMS Technologies Canada Ltd, a wholly owned subsidiary of Honeywell International Inc, will demonstrate that the Aspire 350 AES meets all the Physical Layer and Satellite Subnetwork requirements by providing pre on-air test results data to Iridium LCC. Iridium will review the test results and will determine whether the Aspire 350 is fit for operating in the Iridium L-band Satellite Network and will not cause any harm to any communications equipment operating in the Iridium L-band frequency band as well as outside the Iridium L-band frequency band.

EMS Technologies Canada Ltd, will be ready to conduct the OTA testing after the successful completion of all pre on-air testing and Iridium LLC's approval.

In preparation for the OTA testing after the successful completion of the pre on-air testing, EMS Technologies Canada Ltd, would like to make a formal request to the FCC to grant us a compliance testing experimental radio license, pursuant to CFR Title 47, Part 5, Subpart G, for a period running from May 2021 to May 2022 to conduct OTA tests with the Aspire 350 Iridium SATCOM system for purposes of demonstrating compliance to the certification requirements of the Iridium Satellite network in the L-band.

Pursuant to CFR Title 47, Part 5, subpart 5.505, compliance testing experimental licenses are exempt from complying with the station identification requirements of subpart 5.115 and as such Aspire 350 will not be required to transmit station identification messages.

Name of Requestor: Yohannes Bisrat

Title : Sr Systems Engineer

Email Address : Yohannes.Bisrat@Honeywell.com

Phone Number : 613-595-7979

Address of EMS Technologies Canada Ltd:

400 Maple Groove Road, Kanata, Ontario, Canada K2V 1B8

Date of Request Preparation: Mar 5th, 2021

Appendix A LGA Dual Patch Data Sheet



Dual Iridium Airborne Antenna, TSO Model: AT1621-23

This low profile dual element, dual output antenna is certified by Iridium and is FAA TSO C-159a approved for installation on all aircraft including Air Transport Category, Business Jets, Military, and General Aviation airframes. When used with Iridium certified satellite data units (SDU) it will provide high quality Future Air Navigation (FANS) in-flight safety communications to aircraft traveling in high traffic oceanic and polar routes and voice and data communications worldwide.

The AT1621-23 can be installed within 40" of an AeroAntenna TSO C-190 approved GPS Antenna without any negative impact to GPS reception.



Specification:

Frequency	1616-1626 MHz	
Polarization.....	Right Hand Circular	
Axial Ratio.....	3 dB max at bore sight	
Radiation Coverage	Gain	Elevation
	+3.1 dBic	$\Theta = 0^\circ$
	+2.0 dBic	$0^\circ < \Theta = 75^\circ$
	+0.1 dBic	$45^\circ < \Theta = 70^\circ$
	-3.4 dBic	$70^\circ < \Theta = 82^\circ$
Impedance.....	50 Ω	
VSWR.....	$\leq 1.8:1$	
Power Handling.....	20 Watts	
Finish	Polyurethane enamel, Fluid resistant.	
Connectors	Two TNC Female	
Weight.....	1.1 lbs max	
Altitude.....	50,000 fts	
Operating Temp.....	-55°C TO +71°C	
Design to meet.....	DO-160F	
	ENV. CAT., F2-AB[BD]	
	[S(CLMY)U2(FF1)]XSF5F5ZXXXXXX2A2ACAC	
	RTCA/DO-262A	
TSO	C159a Incomplete	

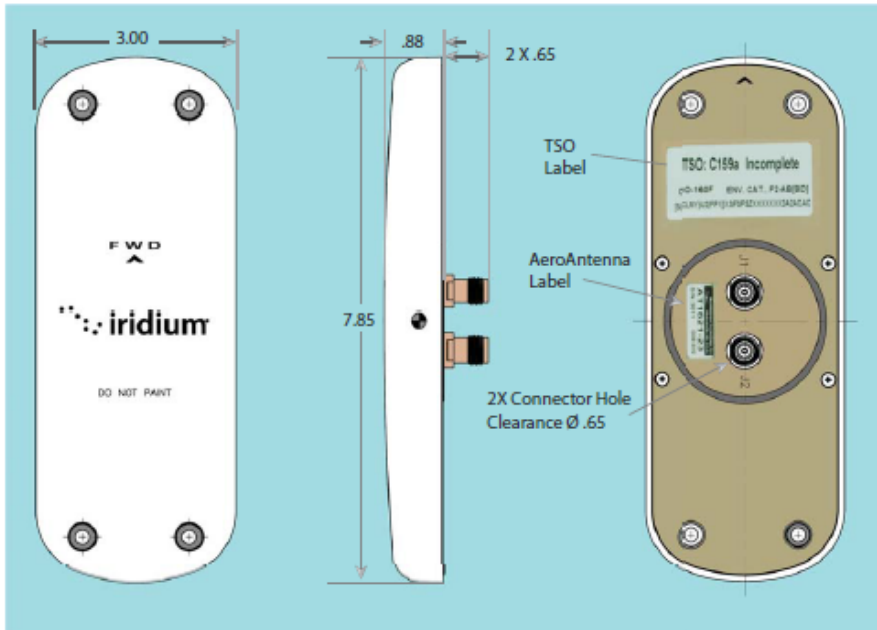

AS 9100 Certified Company
 20732 Lassen Street, Chatsworth, California USA Tel: 818-993-3842 Fax: 818-993-4525
 Sales@aeroantenna.com

Appendix B LGA Iridium Certification Letter



Thursday, 21 July 2011

AeroAntenna Technology, Inc
20732 Lassen St.
Catsworth, CA 91311
Attn: Tami Viviani

Reference: Agreement between Iridium Communications Inc. ("Iridium") and Aero Antenna Technology, Inc ("AeroAntenna")

Dear Tami;

All defined terms used in this letter shall have the meaning set forth in the Agreement. Based upon AeroAntenna's successful fulfillment of all of the requirements specified in the Agreement (including any specific requirements which may have been waived by Iridium as specified below), Iridium hereby certifies the Aero AT1621-23 Antenna for commercial use in connection with the Iridium Communications System as follows:

Equipment Description:	Aero AT1621-23 Antenna
Test Description:	Testing based on Iridium Compliance and Test Requirements for VAM Products
Report:	RPT_04574_Aero_AT1621-23_Antenna_Test_Report.pdf

This certification by Iridium is limited in scope to the specific capabilities defined in the ICE specifications provided by you and successfully tested as described in the Test Description. This certification certifies only that (a) the Iridium Communications System and (b) any Product or Service that is used in conjunction with the ICE, are not harmed, impaired, hindered, damaged or otherwise adversely affected by the ICE. Iridium does not certify or otherwise make any representation or warranty to the public or any third party, Subscriber or other end user as to the quality, effectiveness, reliability, performance or safety of the ICE, and any representation or statement by AeroAntenna (or its agents or distributors) to the contrary shall be deemed a material breach of the Agreement and Iridium may terminate the Agreement.

As set forth in the Agreement, in the event of an Enhanced ICE, AeroAntenna must obtain a Re-Certification Letter from Iridium in order to market and sell the Enhanced ICE. Failure to obtain re-certification shall be deemed a material breach of the Agreement and Iridium may terminate the Agreement.

In the event that a significant ICE defect or abnormal scenario (including a significant Iridium Communications System defect which can reasonably be attributed to the ICE) is identified subsequent to the issuance of this certification, Iridium reserves the right to immediately withdraw certification at any time. AeroAntenna shall cooperate with Iridium as necessary to evaluate the defect and to re-issue such certification of the ICE.

Should you have any questions regarding this ICE Certification Letter, please contact the undersigned at +1.703.287.6244.

Sincerely,

Le-Marie V.J. Thompson
Product Manager, Product Management

1750 Tysons Boulevard, Suite 1400 | McLean, VA | 22102 USA
tel: +1.703.287.7400 | fax: +1.703.287.7450

www.iridium.com



Appendix C Acronyms

AES	Aircraft Earth Station
APSK	Amplitude Phase Shift Keying
APV	Antenna Pointing Vector
ARINC	Aeronautical Radio Incorporated
BAA	Broadband Active Antenna
BAC	Broadband ANC OpenPort
BAE	Broadband Application Electronics
BBP	Broadband Platform
BCX	Broadband Core Transceiver
HGA	High Gain Antenna
LRU	Line Replaceable Unit
MHz	Mega-Hertz
OAA	On Air Approval
OTA	Over the Air
OTS	Over the Satellite Testing
Ref	reference
SATCOM	Satellite Communications
SCM	SDU Configuration Module
SDU	Satellite Data Unit
SV	Satellite Vehicle
TSC	Test Services Center
UT	User Terminal
UUT	Unit Under Test