

Digisat International
Tim Cloonan

Support Documentation for OET-EAE Temporary License

FRN 0030682314 STA 0369-EX-ST-2021

email tim@digisatintl.com

19 MARCH 2021

phone: 201.375.5655

Following information is for support of DIGISAT INTERNATIONAL temporary experimental license through the FCC office of OET. FRN 0030682314 and STA 0369-EX-ST-2021 confirmation EL881239

Testing is conducted in Brevard county, Florida on a temporary test range outside of Melbourne city. The test period requested is for six months from 30 April 2021 to 28 October 2021.

Temporary RF Test Range



Testing will be performed at a temporary RF test range approximately 11.2 km west of Interstate 95 and 1 km south of 192 near the town of West Melbourne, FL. The GPS coordinates for this location are approximately 28 04' 36.9" N by -80 49' 09.2" W.



The test field is agricultural land with a clear flat area approximately 1200 meters long by 125 meters wide.

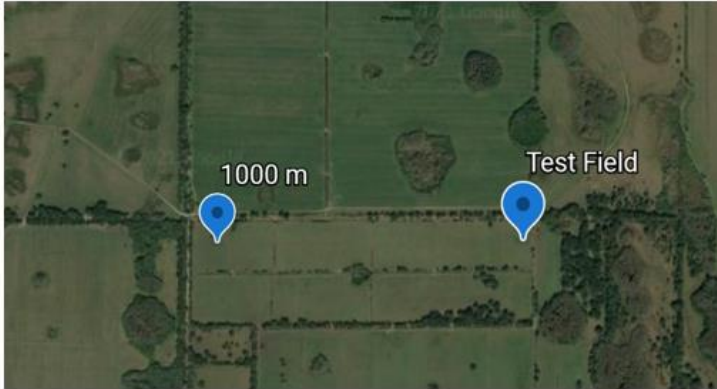

Transmit Center Frequency: 29.7750GHz
Frequency Tolerance: <5% (+/-1250KHz)
Maximum Bandwidth: 20MHz



RF Test Band

FREQUENCY PLAN

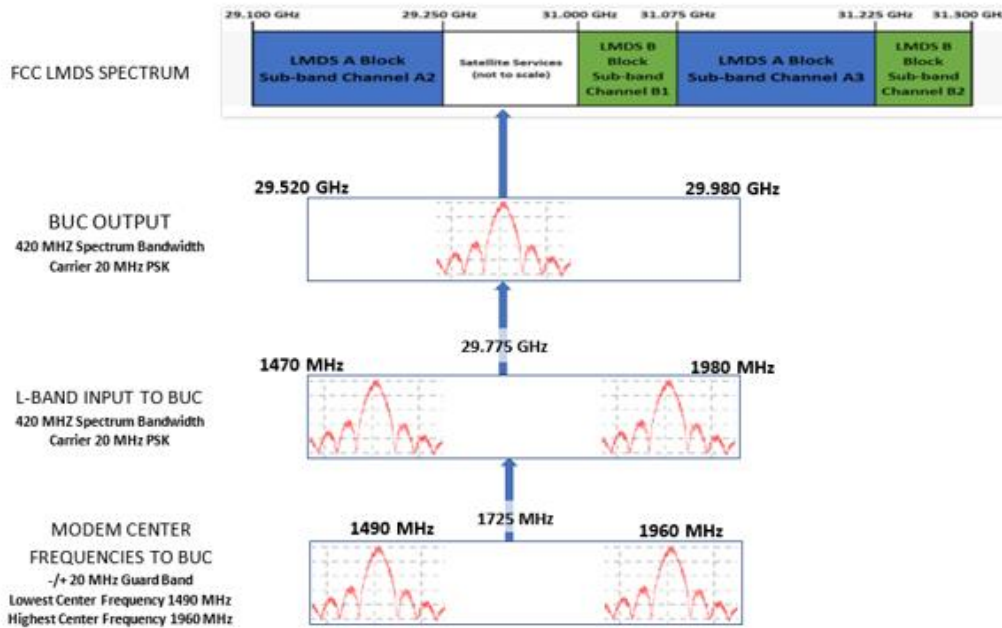

Transmit Antenna Pointing: Elevation 20°- 30° Azimuth 180°W

Tx Antenna Height: 1.5meter Receiver Height: 10meter Distance up to 1000m

Purpose: Compare reduction of radiated induced by RF barrier

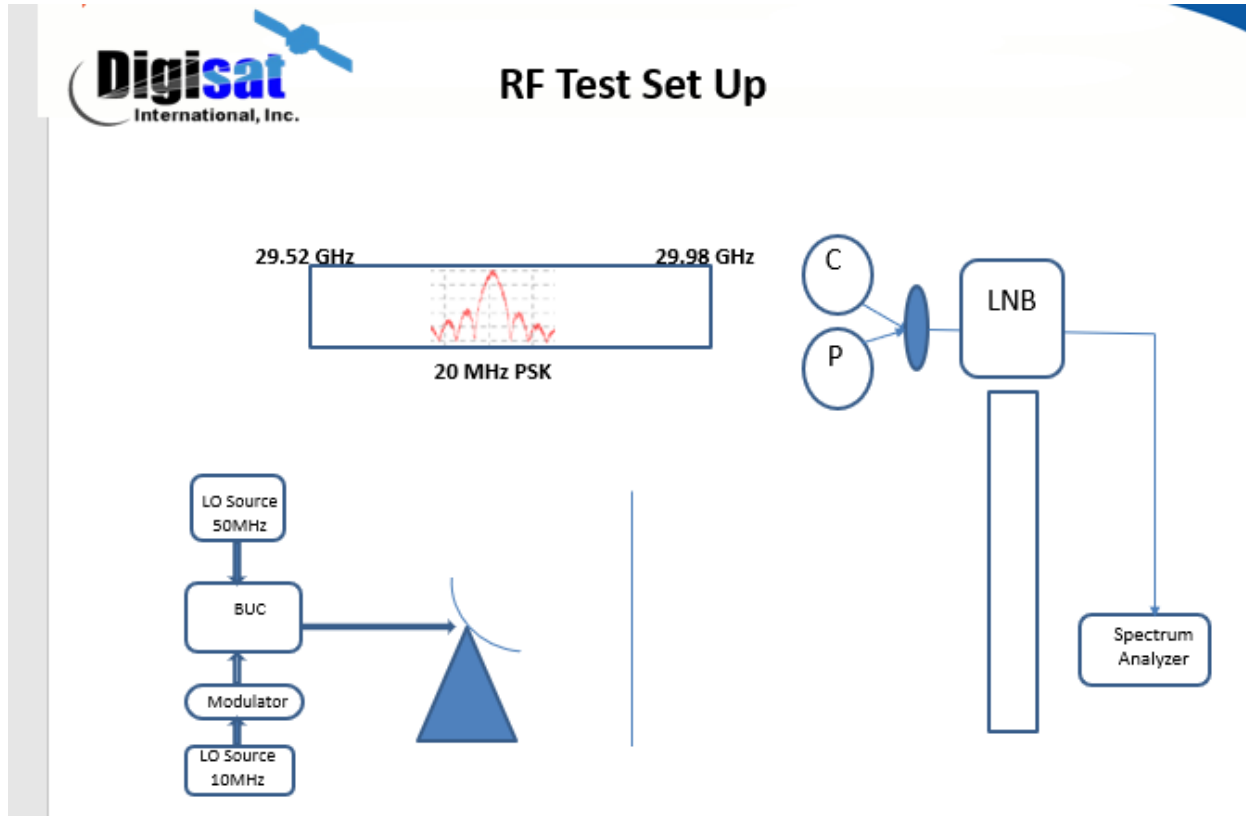

Transmit Antenna: GD Satcom (formerly Prodelin) type approved Ka-Band VSAT terminal

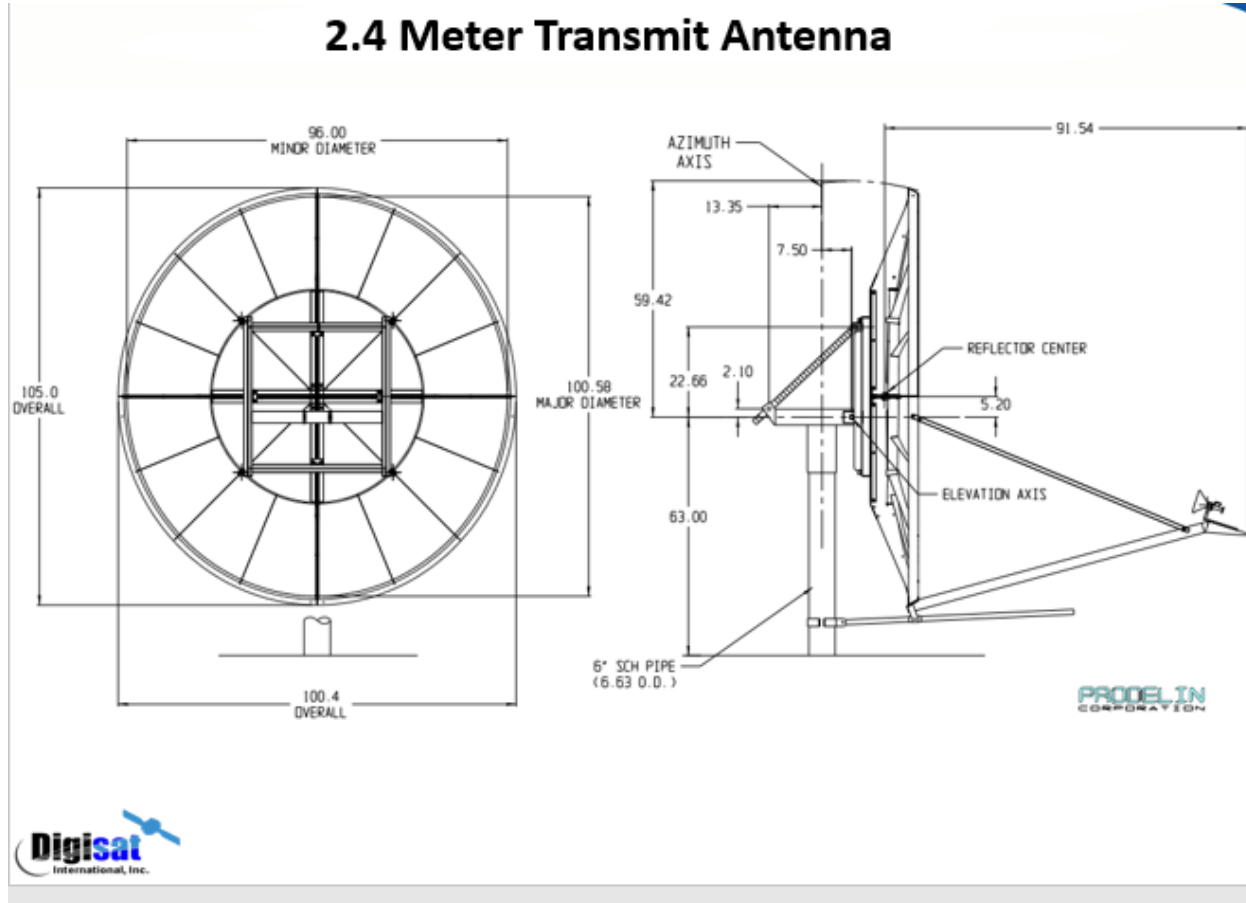

Transmit Antenna Specifications:

2.4 Meter Transmit Antenna

Technical Specifications

Electrical	Ka-Band Circular	
Antenna Size	2.4 M	
Operating Frequency (GHz)	Receive	19.40 - 21.20 GHz
	Transmit	29.20 - 31.00 GHz
Antenna Gain at Midband (± .2dB)	Receive	51.50 dBi
	Transmit	54.30 dBi
VSWR	1.3:1 max	
Pattern Beamwidth (in degrees at midband)	-3dB	Rx: 0.42° Tx: 0.29°
	-15dB	Rx: 0.95° Tx: 0.64°
Sidelobe Envelope, Co-Pol (dBi)		
100λ/D ≤ θ ≤ 20°	29 - 25 Log θ dBi	
20° < θ ≤ 26.3°	-3.5 dBi	
26.3° < θ ≤ 48°	32 - 25 Log θ dBi	
θ < 48°	-10 dBi (averaged)	
Antenna Noise Temperature	5° Elevation	154 K
	10° Elevation	128 K
	20° Elevation	108 K
	40° Elevation	97 K
Power Handling	100 W	
Cross Polarization Isolation		
On Axis	Rx: 17.70 dB	Tx: 21.30 dB
Within 1.0 dB Beamwidth	Rx: 17.70 dB	Tx: 21.30 dB

Radiation Pattern: Boresight Gain: 54.4dB
Off Boresight Gain $_{20^\circ}$ to $30^\circ > -60$ dB

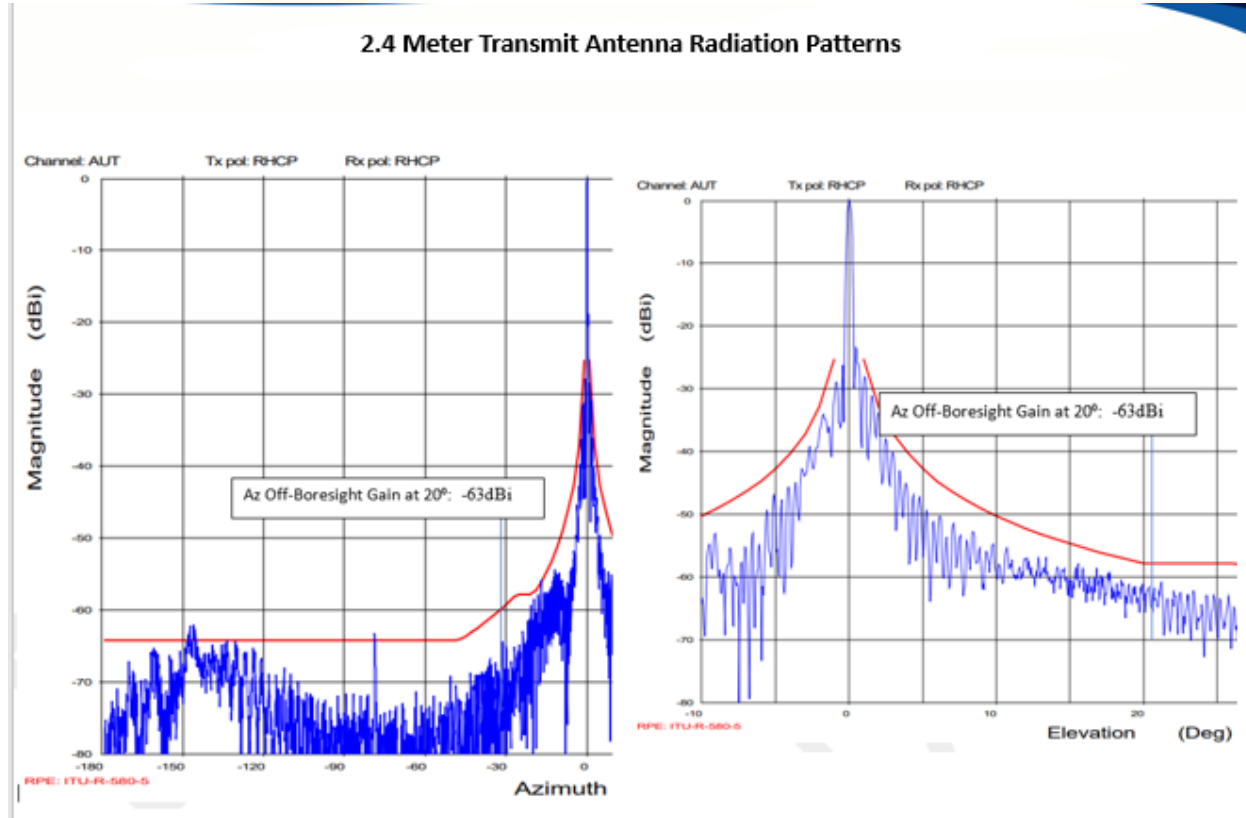

Transmitter Block Upconverter BUC:
Transmit Output Power: 5Watt

NJT5830 Ka-Band BUC

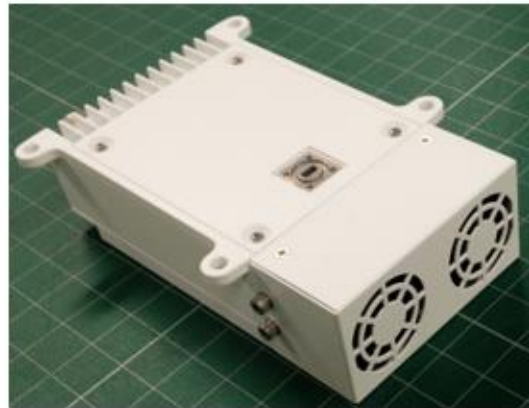

Transmitter BUC Specification:
Maximum Output Power: 5w (37.0dBm)

NJT5830 Ka-Band BUC

BUC Electrical Specification	Min	Nom	Max	Unit
Input/Output Frequency Range				
Output Frequency Range (Tx RF)	29.0		30.0	GHz
Input Frequency Range (Tx IF)	950		1950	MHz
Output Linearity Characteristics				
Maximum Operational Power (MOP): Compliance with 1Msps, $\alpha=0.2$ (Over Temperature and Frequency – with calibration)				dBm
[5W, Q/8PSK]	+37.0			
[4W, BPSK]	+36.0			
ACPR at MOP, with B/Q/8PSK, 1Msps, $\alpha=0.2$ modulated output power: measured at first sidelobes over temperature			-20	dBc
Modulation Error Ratio (MER) Degradation at MOP	19			dB
AM-to-AM Conversion			1	dB
Gain Roll-Off Post Input Level of MOP	-1			dB/dB
AM to PM Conversion:				
Power Through GPIO Connector (for GX use)			6	
Power Through Coax Connector (not for GX use)			10	
Passband Characteristics				
Linear Gain	58	62	66	dB
Gain Ripple over frequency				
Max-Min, any fixed temperature			5	dBp-p
Max-Min, any fixed frequency			5	
Gain Ripple Over Frequency at fixed temperature				
Over any 5MHz			0.5	dBp-p
Over any 36MHz			1.5	
Group Delay Variation				
Over any 5MHz			2	ns p-p
Over any 36MHz			4	

Source L-Band Test Equipment

Signal Vector Generator: Provides PSK modulation waveform B/QPSK to drive transmitter (BUC)

Test Equipment

		Sample Equipment
L-Band Signal Generator	100 Hz to 2.7 GHz	MG3740A
Ka-Band LAN / USB Power Sensor	10 MHz to 33 GHz	L2053XA
L-Band Spectrum Analyzer	1 MHz to 8 GHz	S820E

