



Kapsch TrafficCom

## **Kapsch RIS-9160.** *V2X Roadside ITS Station.*

**RIS-9160 is the latest generation Kapsch 5.9GHz Roadside Unit (RSU). RIS-9160 provides IEEE 802.11p™ wireless communication for both the ETSI ITS G5 and IEEE WAVE standards for applications within the Cooperative ITS (C-ITS) environment and ITS applications based on communication technology in general. Various configuration options and open interfaces contribute to the scalable and future proof RIS-9160 platform. The RIS-9160 provides fast data exchange between vehicles and the infrastructure e. g. Traffic Management Center or Signal Controllers to enable full capabilities of cooperative systems.**

The V2X Roadside Unit supports up to two 5.9GHz radio channels and is based on a ruggedized high performance Linux driven dual-core 64 Bit single board computer platform utilizing extensive interface capabilities while keeping the advantages of Power Over Ethernet (PoE) feed-in and passive cooling.

The product comes with standard compliant V2X communication stack as needed for deployment in IEEE WAVE™ and ETSI ITS G5 based cooperative systems. A software development kit (SDK) is available for

integrators and infrastructure operators allowing them to create own software applications running on the device.

Due to its modular design the product is able to be delivered in different hardware configurations. The modularity helps sustainable infrastructure investments with respect to evolutions within the C-ITS environment, especially in technical, legislative and standardization aspects.

The IP67/NEMA 4X conform housing is made of die cast aluminum designed for long life roadside deployments in rural and urban environments.

Extended temperature range, shock and vibration durability combined with high MTBF are the key factors for sustainable, reliable and maintenance-efficient large-scale field deployments.

RIS-9160 represents the latest generation of Roadside ITS Stations (R-ITS-S) providing V2X applications a powerful computer platform for “Day 1” V2X use cases and beyond.

The product targets the worldwide 5.9 GHz ITS market and thus is compliant to EC RED and US FCC radio regulations

## Technical features

### ITS protocol standards

- IEEE 802.11p™/IEEE 802.11™
- SAE J2735 2016
- ETSI ITS-G5 standard set
- IEEE WAVE 2016 standard set

### 5.9GHz radio characteristics

- IEEE 802.11p™ radio
- Freq. band: 5.850 – 5.925 GHz
- 10 MHz channel spacing
- Output power: max. 20 dBm
- Sensitivity: typ. -92 dBm @ 6 Mbps
- Antenna 1 (or 2, 2<sup>nd</sup> radio chann.).

### Power supply

- PoE 802.3at-2009
- < 14 W (basic configuration)  
max. < 25 W

### Enclosure

IP67, IEC 60529

### Positioning and time (pps)

Multi GNSS (GPS, GLONASS, Galileo, BDS)

### External interfaces (incl. options)

- 2 x 5.9 GHz Antenna 50 Ohm, N female
- 1 x GBit Ethernet (1 x PoE feed-in)
- 1 x GPS, N female
- 3 x Auxiliary, N female (e.g. LTE)\*
- 3 x GPIO\* in, 3 x GPIO\* out
- 2 x LED, 3-col.(power, status) +2 x\*  
\* Option

### Security

- ECC
- Hardware Security Module

### Environmental conditions

- Operation: -40 °C to +74 °C
- Storage: -40 °C to +85 °C
- Protection: NEMA Type 4X, IP67

### MTBF

> 100.000 hours

### Mechanical

- Aluminium die-cast
- Dimension: 290 x 200 x 78 mm  
(w/o installation bracket)
- Weight: 3 kg

### General conformity

FCC, CE

### Configuration options

- Cellular modem module (3G/LTE)
- WiFi module
- BT module
- 3 x GPIO in, 3 x GPIO out
- 24 V / 48 V DC

### Computer platform

- 1,33 GHz, 64 Bit, dual-core
- x86 CPU Architecture, 1 GB RAM ECC
- 4 GB Flash
- SD-Card Slot
- SSD Slot

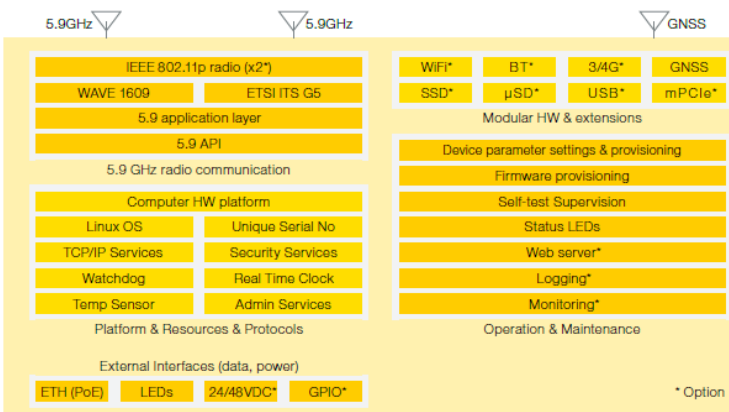
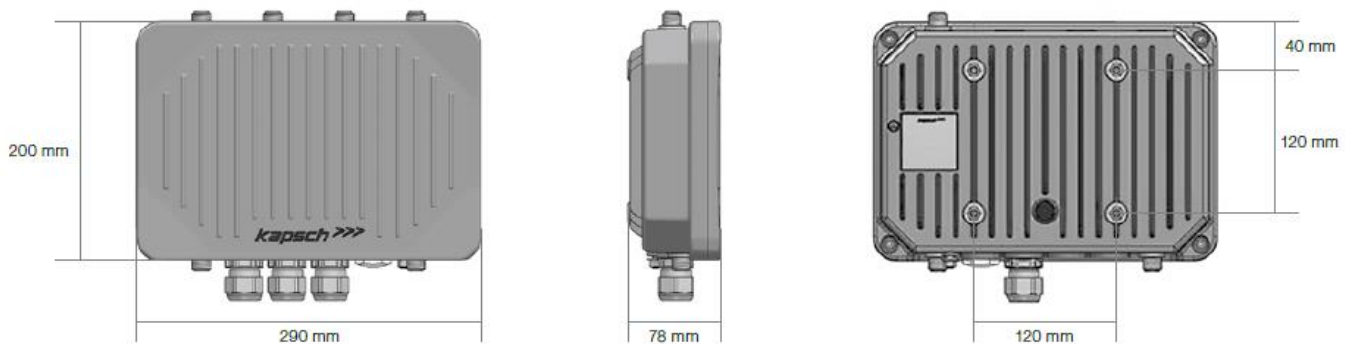

### Interfaces

- IEEE 802.11p(TM) (ITS G5 and IEEE WAVE)
- WAN Ethernet (PoE)
- WAN Cellular Network
- Traffic Management Center / Central ITS Station
- Traffic Light Controller

### References

