

Plan for a Volcano Observation UAS Mission at Makushin Volcano



Christoph Kern¹, Angie Diefenbach¹, Jack Elston², Jonathan Stock¹, Matt Fladeland³,
Maciej Stachura², Andy Dietrick⁴

17 October 2019

NOTICE: THIS TRANSMISSION MAY CONTAIN COMPANY CONFIDENTIAL AND PROPRIETARY INFORMATION OF BLACK SWIFT TECHNOLOGIES. ALL RIGHTS RESERVED. THE USE OF THIS INFORMATION IS RESTRICTED. ITS CONTENTS MAY NOT BE DISCLOSED, REPRODUCED OR OTHERWISE ALTERED OR MODIFIED IN ANY MANNER WITHOUT THE EXPRESS WRITTEN CONSENT OF BLACK SWIFT TECHNOLOGIES.

¹ USGS

² Black Swift Technologies

³ NASA Airborne Science Program

⁴ Aleutian Aerial

Table of Contents

Table of Contents	2
Goal	4
Flight plan	4
Possible Takeoff / Landing sites	7
Safety plan for deconflicting with other aviation	10
Real time data telemetry	12
Topography of the volcano's summit	12
Aircraft	13
Aircraft Modification	15
Loads	15
Flight Envelope	16
Aircraft Weight and Balance	16
Applicable Mechanical and Electrical Design Documents	16
Configuration Management	16
Applicable Software Version Description Documents	17
Software Management	17
Listing of Associated Computer Software Configuration	18
Applicable Engineering Analyses	18
Electrical or Mechanical Systems	18
Control station architecture, including functional flow and subsystem performance	18
Communication system architecture, including function flow and subsystem performance	19
Navigation	20
UAS Control	21
Autopilot	24
Abnormal Environmental Conditions and the Effects on Aircraft	27
Icing Conditions	27
Flight Equipment	27
Ground Support Equipment	27
Ground Control Station	28

Flight Operations Description	30
Flight envelope and test plans	30
Operating History	30
Crew Members and Operating Procedure	30
National Airspace Integration	31
Flight phases	32
Critical process points that are established	33
Operations Conditions	35
Maneuvers	35
Required Instrumentations	35
Mission Control Operations	36
Mission Rules and Flight Limitations	36
Nonstandard Operation or Inspection Criteria	36
Associated Checklists	37
Manuals	37
Description of In-Flight Malfunctions or Emergency Conditions	37
Emergency and flight recovery	37
Flight Termination System and Ground Abort	39
HAZARD ANALYSIS	39
Hazard Analysis of Systems and Operations	39
Risk Assessment and Risk Reduction Actions Methodology	41
Risk Matrix	46
HAM Severity Classifications	48
Loss of Asset/Mission Hazard/Risk Severity Classifications	48
HAMs Probability [Pr] Categories	49

Goal

The goal of this mission will be to demonstrate the ability of the Black Swift S2 USA to fly an autonomous volcano observation mission. Using the custom payload(s) developed specifically for the USGS, the S2 will measure the composition and emission rate of volcanic gases emitted by Makushin Volcano (Alaska), as well as perform a photogrammetry survey of the summit area of the volcano. However, the mission goals go beyond just proving the aircraft and sensor technology succeeds in collecting data. The USGS, NASA, and Black Swift Technologies plan to demonstrate how an autonomous volcano observation mission could be flown in the event of a future volcanic eruption. This includes all aspects of the flight planning and flight permissions process, and involves adapting the observation segment of the flight based on collected data telemetered back to the base station in real time. While this is clearly a challenging goal, we feel that only by solving all aspects of this challenge will we be able to demonstrate this new capacity for observation of volcanic unrest.

Flight plan

In order to accomplish this mission, the UAS will take off in an appropriate location near the town of Unalaska, AK. The S2 will then travel approximately 25 km to the west while climbing from sea level to about 6,000 feet (Makushin Volcano's summit altitude). Upon reaching the volcano's summit, video collected by the UAS and telemetered back to the flight team will inform the flight path for the observation flight. After accomplishing the observations, the UAS will then return to the designated takeoff and landing site.

An example gas monitoring flight is shown in Figure 1. This flight was performed by helicopter on 20 August 2019. After taking off from Dutch Harbor airport (DUT) airport, the helicopter flew up the south side of Makushin Valley while climbing to 5,000 ft. Upon reaching the summit area, we were able to determine that the gas plume was blowing towards the north, so the pilot was directed to fly to that side of the volcanic edifice while dropping to about 3,000 ft. Here, traverses were flown back and forth underneath the plume. The data collected by the upward-looking DOAS spectrometer during these traverses was used to derive an SO₂ emission rate (approx. 200 t/d in this case). After 5 traverses, the helicopter climbed to about 4,000 ft, the approximate altitude of the plume on this day. Here, the pilot flew several circles inside the plume. During this time, the in-situ gas sensors measured the relative plume composition (CO₂, SO₂, H₂S and H₂O). The GPS track from the neutral circles was also used to derive the wind speed and direction at the location of the plume. These data are needed to determine the gas emission rate.

After these gas observations, the helicopter climbed up to 6,000 ft and landed on the summit of the volcano to offload a field crew. In a UAS mission, the S2 might instead climb to 7,000 ft and fly a lawnmower-type pattern over the summit area, thereby collecting photogrammetry data with the nadir-facing high-resolution camera. Alternatively, and depending on the required time on target for the gas mission, the photogrammetric survey may need to be flown in a second, separate flight.

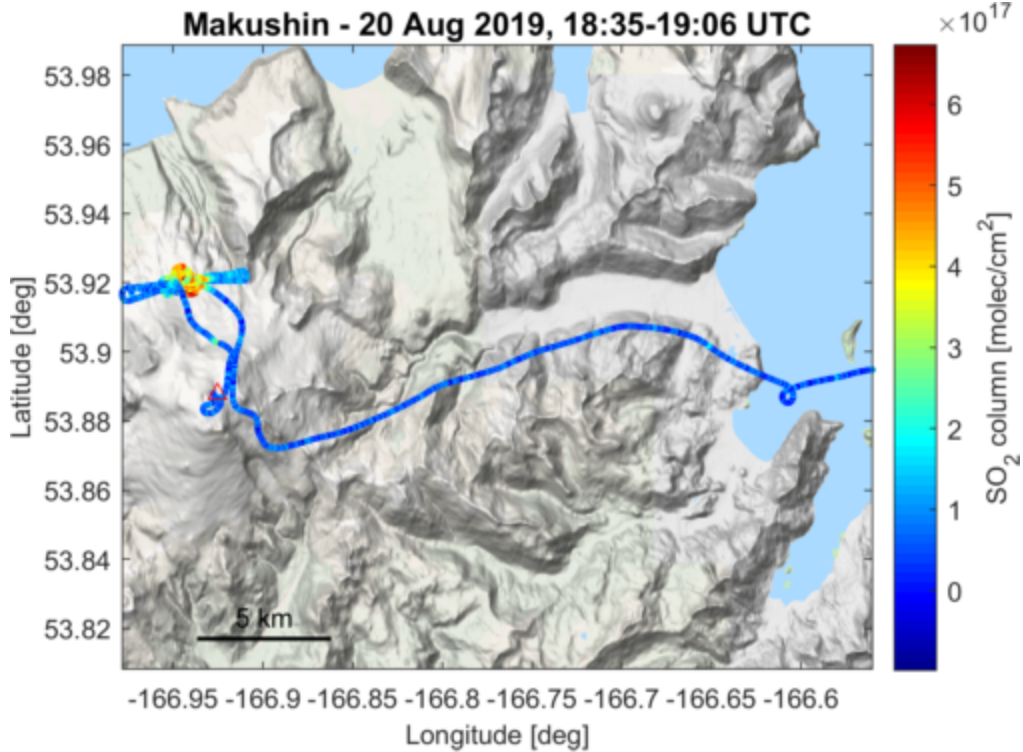

Figure – Flight path of a volcano monitoring mission flown by helicopter on 20 August 2019. The color scale indicates the amount of SO₂ above the aircraft as measured by a DOAS spectrometer.

In summary, the proposed UAS volcano observation flight will take a similar route as this helicopter mission. We envision approaching the volcano by flying up the Makushin Valley while climbing to about 6,000 ft as was done in this observation flight. Given the distance to the volcano, the flight will enter beyond visual line of sight (BVLOS) status en route. The observation segment within about 5 km of the volcano’s summit will then likely differ somewhat, depending on the meteorological conditions found at the summit (see section on real time data telemetry below). After the volcano observations are complete, the Black Swift S2 will then return to base following approximately the same track as during the approach to the volcano.

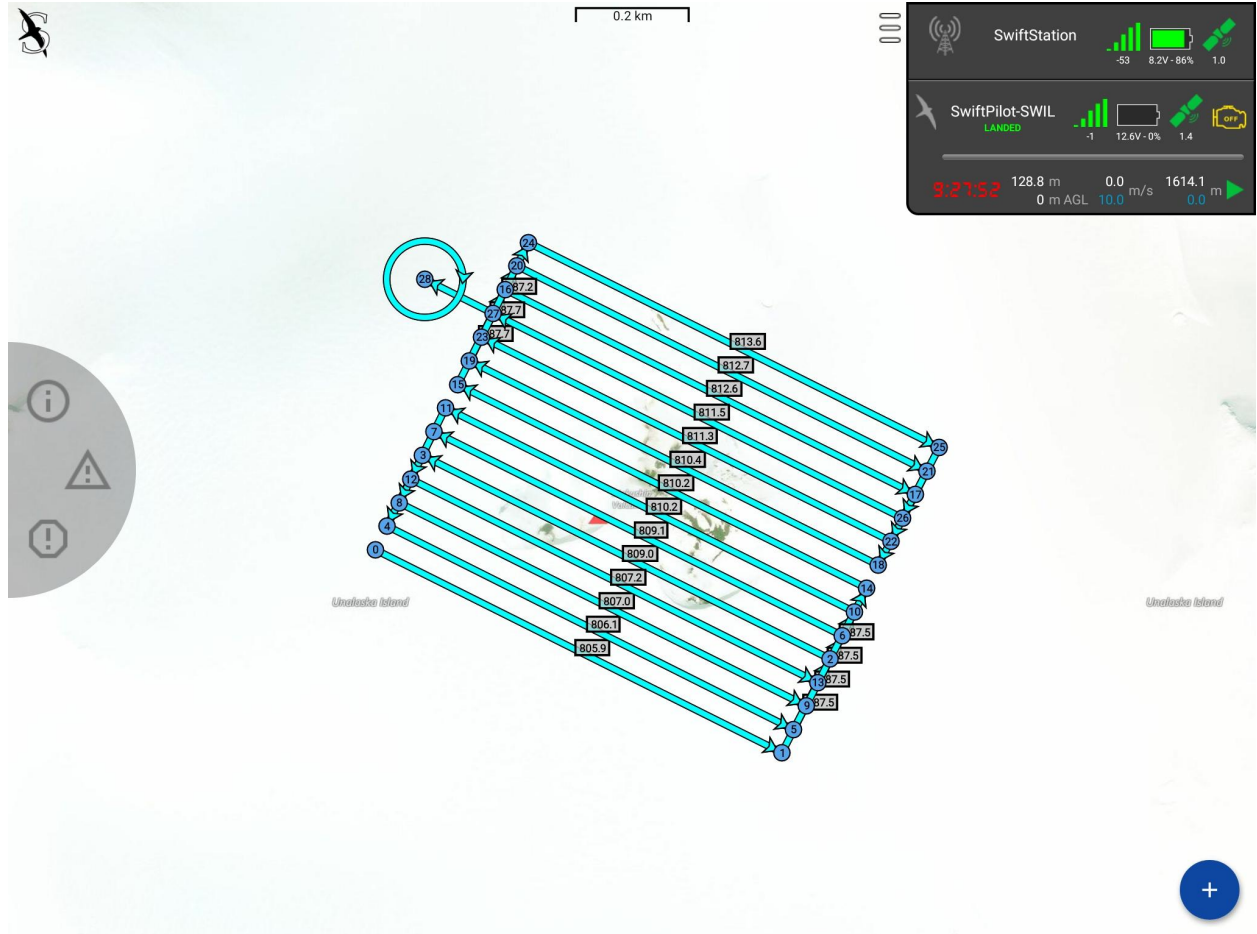

Figure – Example flight plan for performing mapping over the summit.



Figure – Zoomed out view of the above flight path.

Possible Takeoff / Landing sites

We envision that flight operations be based out of a location just to the northeast of DUT airport on Amaknak Island . The FAA maintains a directional beacon and two radar domes at the very north end of the runway. (Figure 2). From this location, the summit of Makushin Volcano is visible to the west (Figures 3 and 4). Besides the antenna used for transmitting the beacon signal, the site is free of obstacles and essentially just tall grass. Flight operations can occur to the west of any FAA infrastructure such that flights do not need to pass by any such infrastructure. Permission for accessing and using the FAA site for operations will be obtained well in advance. Access to the site is by vehicle on a gravel road.



Figure 2 – Google Earth image of DUT airport viewed from the south. The blue dot corresponds to the preferred location for UAS flight operations. It is just west of 2 radar domes operated by the FAA (visible as white dots to the right of the blue marker in this image). The yellow line shows the direction to Makushin Volcano.

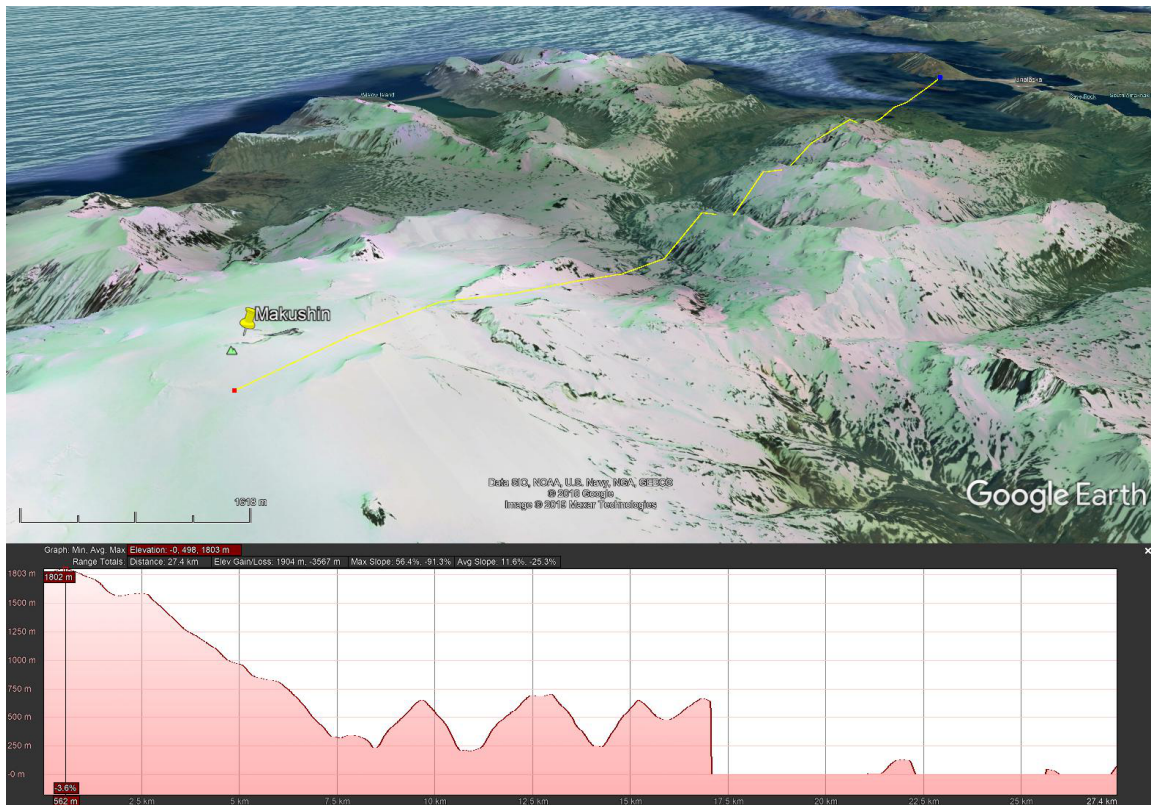

Figure 3 – Google Earth image of Makushin summit in the foreground with the flight operation base station site marked by a blue dot in the background. The terrain profile at the bottom shows that the base site is indeed within line of sight of the volcano's summit.

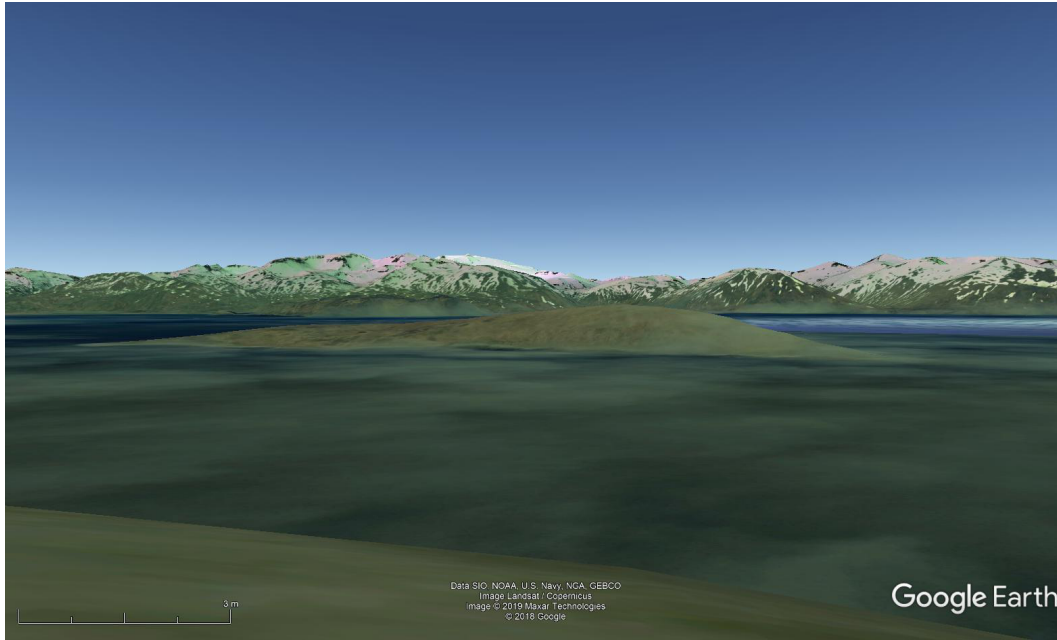

Figure 4 – Google Earth image of Makushin summit as viewed from the suggested flight operations base. The snow-capped volcano is just visible above the closer terrain features.

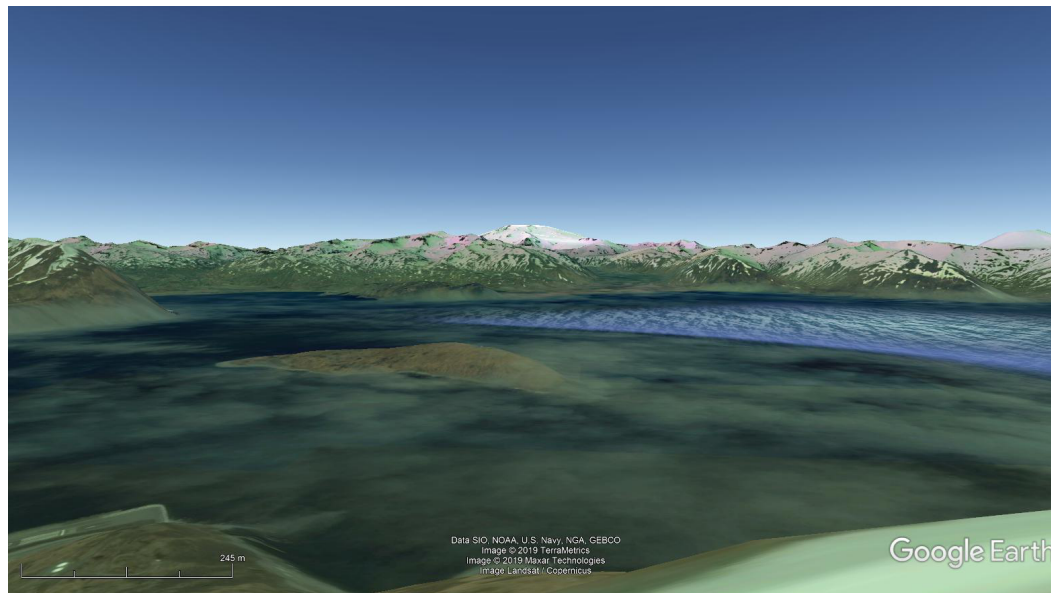

Figure 5 – Google Earth image of Makushin summit as viewed from the top of Mount Ballyhoo, the highest point on Amaknak Island. This site is approximately 1 km to the east of the suggested flight operations base. A telemetry repeater could be placed here if needed for improved line of sight to the volcano.



Figure 6 - Photograph of Makushin volcano taken from the top of Mount Ballyhoo. Compare with Figure 5. Photo by Christoph Kern, USGS.



Figure – Photograph of DUT airport in the foreground and the port of Dutch Harbor in the background, as taken from the top of Mount Ballyhoo. The proposed location for flight operations is just off this image to the right. Photo by Christoph Kern, USGS.

Safety plan for deconflicting with other aviation

DUT is a small airport with a low aviation traffic volume. The three main operators that fly here are Grant Aviation, PenAir (owned by Ravn Air Group), and ACE Air. PenAir traffic is typically 2 flights/day (midday, early evening) with SAAB 2000's (45 pax). Grant traffic can be 1-5 flights a

day or so with King Air's and Navajos. In addition, ACE does cargo runs twice a day, 6 days a week with Beechcraft 1900's.

Other aviation that might be in the area is LifeMed air-medevac with a KingAir, Maritime Helicopters typically with Long Rangers and the US Coast Guard is often in and out with their HH-65 Dolphin tethered to whichever high-endurance cutter is currently stationed in the Bering Sea. Less common aviation would be NOAA marine mammal survey planes, USCG Jayhawks, USCG C-130's, and the occasional chartered PC-12 from Anchorage. There are two civil aviation pilots in town that keep their aircraft based in Dutch Harbor. Both are Cessna's. One is a frequent flyer on most nice days, engages in off-airport landings, and would definitely need to be notified of UAS operations.

The common traffic advisory frequency (CTAF) for DUT is 122.6, and we will also monitor 129.5 (Call Sign: Dutch Weather - 907-581-1256). The Dutch Harbor Airport weather office is on the SE end of the terminal building and is staffed by an FAA contract through AWOS Inc. The weather observer is frequently on the radio throughout the day talking to aircraft, giving weather information, and is usually in the know about what is coming and going. We will work with them to ensure awareness of our operations is passed on to aviation in the area. The flight service station (FSS) for DUT during the day is Cold Bay Radio and at night is Kenai Radio. We will contact FSS in advance of our operations.

The most common arrival is left base runway 13 (E/SE is prevailing storm direction). The second most common is right base runway 31. Both of these are shown in red on the map in Figure 8. On occasion, during north winds or specific visibility limitations, arrivals will come over town on a left base runway 31 approach (blue in Figure 8). Departures are either on runway 31 turning north immediately after takeoff, or on runway 13 turning immediately northeast over the spit and out the bay.



Figure – Map of airspace around DUT airport and Dutch Harbor. The thin red and blue traces drawn on the map show the typical arrivals and departures.

A significant amount of ongoing additional work is planned to construct the safety case for this application.

Real time data telemetry

Despite the fact that flight operations will be beyond visual line of sight (BVLOS) given the distance to the volcano, the flight team will maintain situational awareness through real time data telemetry. Given that line of sight telemetry to the operations base will be possible for most if not all of the observation flight (Figures 3-7), the team will be monitoring data in real time. For one, the Black Swift S2 will have a forward-facing low-resolution video camera feed which will be telemetered back to the base station in real time. This is necessary for assessing the measurement conditions at the volcano's summit from the base station over 20 km away. Also, the gas data will be sent back to the base station in real time so that the team can react to observations in real time and change the path of the observation segment of the flight if needed. All necessary permissions for BVLOS flights will be obtained in advance.

As mentioned previously, a significant amount of ongoing additional work is planned to construct the safety case for this application.

Topography of the volcano's summit

The volcano's summit is characterized by complex topography and multiple degassing features. Winds exceeding 15 knots are common, and at these high wind speeds the plume will often

follow the topography down the flank of the volcano. In such conditions, the UAS would have to fly as low as possible over the terrain to make gas measurements.

A time-lapse video showing photographs of the volcano's summit area from various vantage points is available for viewing here:

https://drive.google.com/file/d/1_xjDMJh4xyKUEF-AKC3306c6Dcfq2pNF/view?usp=sharing



Figure – Photograph of Makushin summit as viewed from the northeast on 19 August 2019. Note multiple gas emission sources and plume hugging the topography

Aircraft

The S2 UAS operated under this flight operations plan is a commercial-of-the-shelf (COTS), fixed-wing UAS built and sold by Black Swift Technologies (BST). The S2 was designed and developed by BST for use in NASA science missions under the SBIR program. The S2 was designed to be a highly efficient, robust, rapidly and easily deployable airframe. It is optimized for carrying payloads up to 5 lbs. It was specifically built with scientific payloads in mind providing easy access and rapid integration of new payloads. The S2 is a fully composite aircraft that utilizes electric propulsion. Figure 1 below shows a 3-view of the aircraft and Table 1 contains the specifications.

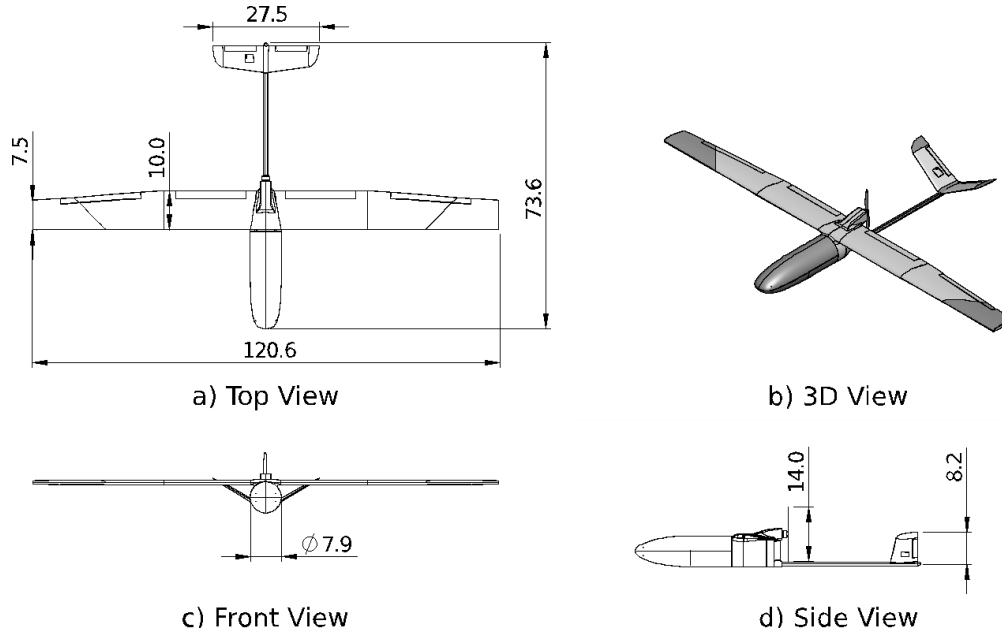

Figure – The S2 UAS

Table – BST S2 Performance data in standard configuration. Dimension are in inches.

Wing Span: 120.6"	Length: 73.4"	Empty Weight: 13.5lbs	Max. Gross Weight: 18.5lbs
Engine (size/rating): KDE4215XF	Propellant Type/Qty: 6S 14Ah	Payload Capacity: 5lbs	Glide Ratio: 14.3:1
Max Speed: 48kts	Cruise Speed: 37kts	Stall Speed: 23kts	Glide Speed: 29kts
Rate of Climb: 950 ft/min	Rate of Descent: 810 ft/min	Max Altitude: 10,000ft	Max Range: 63 miles
Construction: Fiberglass and carbon fiber	Wing Loading: 38.9 oz/ft ²	Max Duration: 90 minutes	Fuel Type: Electric Propulsion

- Electric-powered propulsion systems
 - What type of motor is used? KDE4215XF
 - What is the power output of the motor? Max 1500 W continuous
 - What current draw range does the motor have? 0 – 40A
 - Does the system have a separate electrical source? If not, how is the UAS power managed? No. On-board circuitry will monitor the main battery pack and cut-off propulsion power in the event that the battery is too low allowing the pilot to

glide the aircraft down. This situation will be avoided by terminating the flight with 15 minutes of power reserve remaining.

Aircraft Modification





No modifications were made to the airframe itself for this mission. However, a payload tray was designed around the sensor for this mission. The S2 UAS was specifically designed with a modular and swappable payload section that is separate from the rest of the UAS. This includes a clearly defined mechanical and electrical interface. The payload tray for this mission was designed and built by BST to accommodate the volcanic sampling package.

For maintenance, the aircraft is inspected prior to each flight according to the “preflight” section in the checklists listed in Appendix 2. This pre-flight includes an inspection and testing. Parts of the aircraft (i.e. control horns, servos, wire connections, etc) that either do not function or begin showing wear and tear will be replaced. In general, the aircraft is maintained based on standard practices for RC aircraft. Major maintenance and repairs are documented in the logbook.

Loads

The S2 UAS was built with structural requirements to sustain limit loads of -1.5G to +3.8G and gust loads from -4.2G to +6.2G. The design had a further 1.5 factor of safety on top of these loads. Initial designs of the composite structure were tested to these load limits. Further, early on in testing, the limit loads were tested (and exceeded) in flight to verify the design. The S2 has never had a structural failure in flight.

Table – Payload items and their specifications

Payload Item	Picture	Sensor Characteristics	Weight	Max Power Consumption
BST 5 Hole Probe		3D winds, pressure, temperature, and humidity	50g	0.5W
Licor 850		Measures trace CO ₂ and water vapor	1300g	4.6W
City Tech SO ₂		0-200ppm	17g	0.1W
City Tech H ₂ S		0-100ppm	17g	0.1W

MapIR Kernel		Downward facing still camera.	62g	4W
FPV Video		Forward facing video camera.	75g	6W
Flir Vue Pro R		Downward facing thermal camera.	130g	2.5W
Ocean Optics FLAME-S Spectrometer		Spectrometer	265g	1.25W

Flight Envelope

- Maximum altitude: For this mission the max is 400' AGL.
- Maximum and cruise airspeeds: Maximum speed is 48 kts, cruise is 39 kts.
- Maximum endurance: 1.5 hour.
- Maximum range: 58.5 nm
- Rate of climb: 950 ft/min
- Rate of descent: 810 ft/min
- Maximum glide slope: 15 degrees
- Performance limitations (i.e. wind shear, gusts, visibility, icing, lighting, etc.): Max winds to operate is 20 kts, Visual flight rules for Class E airspace will be utilized.

Aircraft Weight and Balance

The S2 has a maximum GTOW of 18.5 lbs including up to a 5lbs payload. The aircraft is always checked prior to flight to ensure that it is below the payload limit. The balance is checked utilizing a 3D CAD model of the aircraft and all payloads and physically verified by lifting the aircraft by the C.G. markers on the wings. The CG limits of the S2 are from 3.25" to 4.25" from the leading edge of the wing based on both controllability analysis and verified with flight tests. The CG limits are marked on the wings and it is part of the preflight checklists to verify it prior to each flight.

Applicable Mechanical and Electrical Design Documents

Configuration Management

- What procedures are in place to manage change configuration? Are they documented? Changes are managed through subversion, a third party revision control software, combined with Trac, a third party ticketing and bug reporting software suite. Any

changes to the software are traceable through these resources. Changes to the airframe are monitored through the maintenance and repair logs and are available upon request.

- Describe the procedure used for controlled drawings, test procedures, and engineering changes? Documents and drawings relating to engineering or test procedures are similarly maintained through subversion to provide revision control and traceability.
- Describe the quality assurance system, including methods and procedures used and structure within the organization. Black Swift utilizes versioned documents, tracked build logs, and quality control checks of the aircraft, avionics, and all subsystems involved in operating the UAS.

Applicable Software Version Description Documents

Software Management

- In high level terms, how much of the software was designed by the UAS operator? Identify which areas of the system contain vendor software. The majority of the autopilot software was designed by the UAS operator. A few low-level libraries were used in the board support package for the various processors employed for the autopilot. Both the GCS and operator interface software were designed by the UAS operator but run on top of COTS operating systems. The user interface makes use of third party software tool for the display of maps.
- What software development process(es) has/have been used in the development of software components for the aircraft and control station, and what software lifecycle data is available for review? UML was used to design and diagram several of the software components. All software development has been managed through revision control software, and any of the revision data is available for review.
- How will updates to system software (including commercial off-the-shelf software) be implemented? Updates will be performed by branching the working version of the software, and implementing the necessary changes. During this process unit tests will be developed and carried out on the modified sections of the code to verify it's functionality before re-merging with the trunk software.
- Provide a description of the software requirements and the functional allocation between hardware and software. The software for the autopilot system is required to maintain the strict timing, accuracy and robustness required for safe, scientifically useful flights. To limit noise on the sensor values and reduce latency hardware has been chosen to provide digital values from the sensors. The software uses the values from the sensor to provide a state estimate of the aircraft, outputs to the actuators, as well as maintain logging and communications. The separation to keep most of the functionality in software allows for a flexible system able to meet the needs of a variety of missions.
- How is software verified, validated, and tested for the system? New software is tested in the simulation environment using a hardware-in-the-loop setup to verify all functionality. A series of unit tests are also performed on the core autopilot software to verify timings,

noise levels, and sensor readings are within specifications. Finally, everywhere software update goes through a series of flight tests on internal BST aircraft to validate and test the changes.

- How is vendor software development overseen? This project will not make use of vendor software development.
- How is software load control implemented for the system to ensure the correct software components are loaded onto the system? The software has an associated version that is verified by the various components of the system, and the operator will not be allowed to conduct flights with mismatched software or firmware.
- What software quality assurance processes are used in the development of the system software? If software is vendor-provided, vendor control must be addressed. Software quality is ensured through unit testing and thorough software and hardware-in-the-loop simulation.
- What procedures are in place to manage change configuration? How are these documented? The third party software, TRAC is used to manage changes and change requests. TRAC in combination with subversion creates a fully traceable chain for any changes that are eventually merged into the autopilot code.

Listing of Associated Computer Software Configuration

SwiftTab version 3.0.0 build 1812141231 is the user interface software used. It is run on a Samsung Galaxy Tab Active2 Android tablet.

Applicable Engineering Analyses

None applicable, the S2 is a commercial off-the-shelf vehicle.

Electrical or Mechanical Systems

Table – Hardware features

Primary control link:	900 MHz ISM control and telemetry link
Flight electronics:	SwiftPilot autopilot system with associated avionics
Uplink/downlink	10 kbps to 125 kbps half-duplex
Sensor/payload	Volcanic Sampling Package

Control station architecture, including functional flow and subsystem performance

The Black Swift autopilot system allows for user interaction through two different interfaces, a manual handset and the ground control station. The ground control station (GCS) consists of a portable case containing a radio to communicate directly with the UA, a GPS for determining the position of the unit, and a tablet that enables an operator to interact with an attached UA

over a wireless link to the GCS. The GCS sends a heartbeat every second to the aircraft to inform it of the connection status. If the aircraft does not see this periodic message for the amount of time specified for the communications timeout, it will enter lost communications procedures.

The tablet provides a simplified user interface for the command and control of the aircraft. The operator is provided a geo-referenced map pane for spatial awareness which provides a critical subset of the telemetry stream, allowing him to easily identify the current status of the UA. It also allows the operator to create and assign waypoint patterns, along with identifying which waypoint to track. Modification of the pattern is performed through simple touch and gesture commands, and clearly indicates which waypoints modifications have been successfully sent to the aircraft using a separate color scheme for local modifications. If further interaction is desired, this can be performed through a popup window with specific information and available controls for the aircraft. These controls include loops to set the airspeed, altitude, tracked waypoint, and commanded turn rate for the aircraft.

Figure 2 below shows an illustration of the interface. The BST manual (<http://mkdocs.bst.aero/>) contains a more detailed description of the functions of the interface.



Figure – SwiftTab User Interface

Communication system architecture, including function flow and subsystem performance

The manual handset sends commands directly to the receiver on the aircraft. This receiver has direct control over whether the autopilot or handset commands are output to the control surfaces. In this manner, the handset remains a separate backup system that can override the autopilot if necessary. If the receiver does not receive a signal from the handset while in

manual mode the autopilot will automatically take over by putting the aircraft into full auto mode.

The SwiftPilot Pro has been designed to work with a number of communications systems to provide a data link between the aircraft and ground station. For this deployment the system employs the Digi Xtend frequency hopping, spread spectrum (FHSS) radios. They operate in the 902-928 ISM band with a maximum of 1W output power. The radio can provide a data rate of up to 115.2 Kbps, and feature a user-configurable retry and acknowledgement error-handling scheme. The radios can also employ 256-bit AES encryption to secure the data link.

Figure 3 below contains an illustration of the communication architecture of the entire system. The R/C channel is a redundant system running at 2.4GHz spread spectrum. The tablet also utilizes WiFi to connect to the GCS.

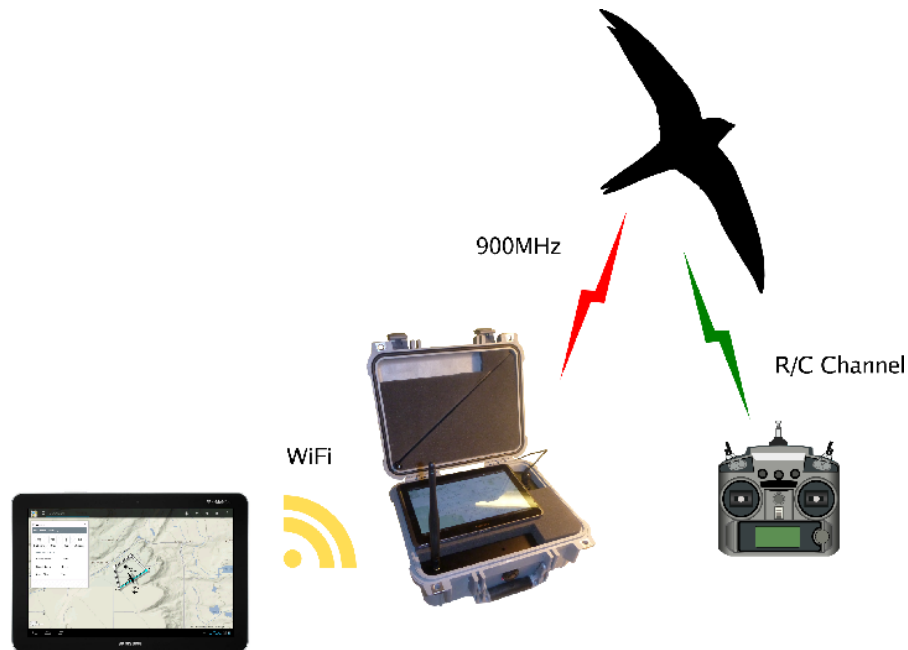

Figure – Control Architecture

Navigation

- How does the UAS determine where it is?: GPS Position
- How does it navigate to its intended destination?: PID based control loop comparing the measured heading to the desired heading generated by the internal navigation algorithm.

- How does the UAS respond to the following directions from ATC?: N/A
- Change in heading: Through the ground control station or manual pilot control.
- Change in altitude: Through the ground control station or manual pilot control.
- What are the causes and effects of loss of heading or altitude?: Loss of GPS will result in losing the heading. If the UAS loses GPS it will default into holding a fixed bank angle, whereupon the manual pilot will take over the aircraft and land. Losing altitude requires loss of both GPS and the static pressure sensor simultaneously. In this event the UAS will go into lost GPS mode, where it holds a fixed bank angle, and also cut the engine holding a set airspeed to ensure a slow descent.
- Describe the procedures to test the altimeter system (14 CFR 91.411, Altimeter system and altitude reporting equipment test and inspection): N/A, however calibration and correction to the pressure altimeter is done with the GPS.

UAS Control

- Describe the overall flight control system used by the UAS (mechanical linkage, hydraulic, fly by wire, servos, types of control surfaces, etc.). Provide a diagram showing the location of the servos and control surfaces, and power to the servos: The flight control signal generated by the autopilot is sent over a CAN bus to servo control boards where it is interpreted into a pulse-width modulated signal that can be used to directly control the deflection of a servo. The servo is connected to the flight control surface by push-rods and standard r/c interface components (see Figure 4 below). The linkages in the wing for the ailerons, rudder, elevator, and flap surfaces are very short to reduce non-linearities when actuating the surfaces.

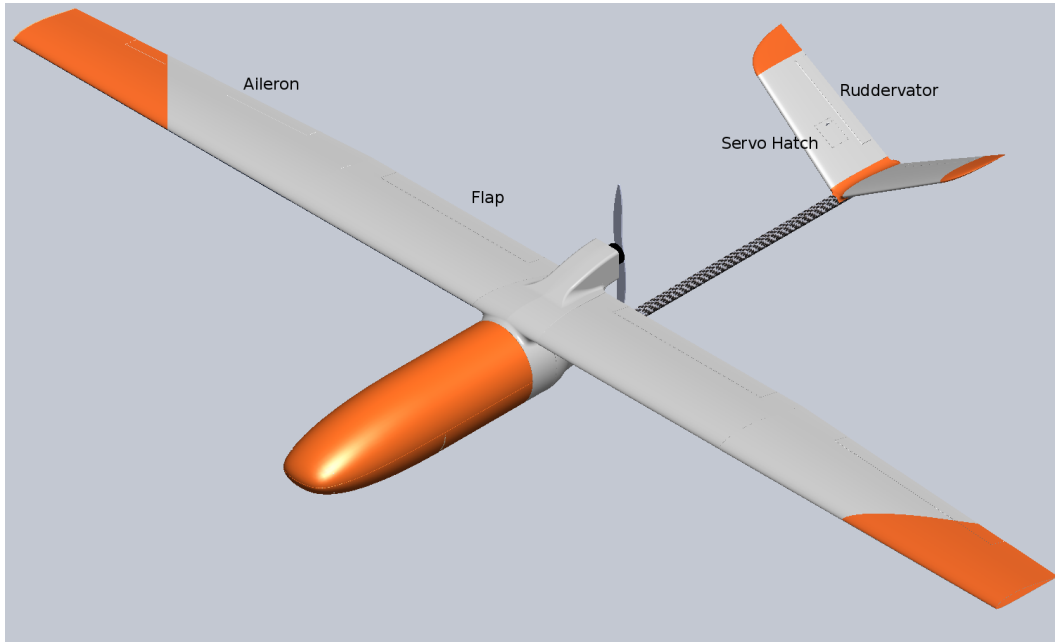

Figure – S2 Surface and Servo Location

- Description, location and drive mechanism of primary flight control surfaces (i.e. single conventional rudder, vertical stabilizer, servo driven): All surfaces are servo driven. The wing and tail surfaces are actuated by individual servos with short linkages to reduce non-linearities.
- Description, location and drive mechanism of secondary flight control surfaces (i.e. segmented slotted flaps, inboard wing trailing edge, servo driven): The aircraft contains no secondary flight control surfaces.
- Describe automated flight control system and software used (if applicable): The flight control is performed through the COTS SwiftPilot Pro autopilot from Black Swift Technologies. This is a proven system and has been used in flight experiments involving several different airframes covered under a number of FAA COAs. The autopilot system consists of a ground control station (GCS), tablet based user interface, radio system and the autopilot itself. Through the user interface the operator is able to monitor health and status of the vehicle, change mission parameters, and control the behavior of the aircraft through flight plans and control parameters such as desired altitude and indicated airspeed. Overall, the aircraft parameters can be changed inflight at the discretion of the PIC. The software algorithms are able to handle emergency and lost link situations using FAA approved procedures and parameters set by the operator. It additionally contains the option for a separate manual pilot backup link in case of failure of the primary autopilot system.

- Describe any automated secondary control systems (yaw damp, airspeed driven flap system etc.): Automated control systems where the aircraft changes modes without user input include:
 - Loss of radio control link – the system will switch to autonomous mode to control the aircraft.
 - Loss of flight control system command link – the autopilot will switch waypoints to the lost communication waypoint.
 - Loss of GPS – the autopilot will bank the aircraft and hold a steady turn.
- Provide a description of failure modes and conditions along with mitigations of each mode: During pilot-in-the-loop automatic control, if the aircraft senses a loss of communications, it will switch to a mode where it returns to a known location to try and re-establish contact. If contact is not established within 5 minutes, the aircraft will begin a slow spiraling descent to aerodynamically terminate the mission. If the operator is able to re-establish communication at any point in time, he can then proceed to command the aircraft back to its mission, or chose to move to another phase of the flight, such as landing.
 - If under automatic control a GPS outage is sensed, the aircraft will bank 20 degrees and altitude hold mode to try and re-acquire the GPS signal. The operator is notified of the GPS outage status through the user interface. Should a lost link event occur during a GPS outage, the autopilot will immediately switch to an aerodynamic termination mode where the 20 degree bank is held and the engine is disabled to slowly descend. Since this entire mission is within line of sight, the PIC will take over manual control if there is a GPS outage and land the aircraft.
 - If power to the motor is lost during automatic flight, the autopilot is capable of maintaining airspeed while descending. It will notify the operator of the inability to maintain altitude through the tablet interface.
 - How does the system respond to a servo failure? The system does not actively detect this. It will be the responsibility of the PIC to notice it through control degradation and alert the manual pilot to take over and attempt to land the aircraft.
 - What indications alert the pilot that a servo is stuck? Control degradation will be clearly apparent in the autopilot telemetry (orientation during flight or system current draw), system warnings, or through visual cues.
 - Describe how the control surfaces respond to commands from the flight control computer. Describe how the pilot provides input to the control surfaces (for example, through an external box, waypoint, stick and rudder pedals). The control commands are sent over a vehicle wide CAN bus to individual servo control boards. The control boards then interpret the bus messages and then convert them to PWM signals which are used to control the deflection of the

COTS servos. The commands sent over the bus can come directly from the autopilot itself, or through a R/C receiver in the loop that is used to provide manual control through a COTS R/C transmitter.

- Provide a description of the procedures in place to prevent failures due to weather or icing. The system has been flight tested in winds up to 30 knots. The system can fly through mild precipitation, and steps have been taken to provide water resistance.
- No current procedures exist for mitigating icing other than operator education to identify the increased throttle usage and poor system performance associated with the start of icing.
- Does the flight control computer interface with auxiliary controls that might cause unintended action? The flight computer interfaces to a COTS R/C receiver over a CAN bus, both of which are capable of controlling the primary surfaces. Communication between each over the CAN bus ensures that only one device is controlling the surfaces at time.
- Describe the systems the flight control computer interfaces with to determine flight status and to issue appropriate commands: The flight control computer mainly interfaces to the ground station wirelessly to receive commands and report flight status.

Autopilot

- Is the autopilot a commercial off-the shelf product? If so, name the type/manufacturer. Yes, the SwiftPilot Pro from Black Swift Technologies.
- Describe the procedures you use to install the autopilot. How is correct installation verified? Reference any documents or procedures provided by the manufacturer and/or developed by your company. The autopilot used in this system is developed by Black Swift Technologies. Installation involves rigidly attaching the autopilot to the airframe oriented according to the markings on the autopilot. This installation is the same as the commercial version of this system, the S3.
- Does the autopilot employ input parameters to keep the aircraft within structural limits? If so, provide a table of these limits. How were these limits validated? The aircraft is limited to a maximum airspeed of 48kts in the parameters page, pitch limits of -15 degrees to 25 degrees, and +/- 45 degrees in roll. The Vne of the S2 is 80 kts, which is well above the limit of 48kts.
- Where do the autopilot commands reside once they are input by the pilot? The autopilot commands always reside on-board the autopilot. They are displayed on the

user interface. New commands issued to the user interface are colored in red until confirmed by the autopilot.

- What type of software-in-the-loop (SIL) and hardware-in-the-loop (HIL) simulations have been performed? What was the outcome of the simulations? Software in the loop simulations have been performed of the full mission with SwiftPilot SIL simulator. The simulator utilizes X-Plane to simulate the aircraft.
- Will autopilot system change-outs occur on any flights during this operation? If so, what is the reliability of each system? No.

Communications

- List all the frequencies that are available and/or used by the UAS.
 - 900MHz ISM control and telemetry link.
 - 2.4GHz radio control system for manual handset flight.
 - 1575.42 MHz GPS receiver.
- How do you limit the likelihood of unplanned loss of communications between the pilot and the UAS due to the following?
 - Radio frequency or other interference: The COTS radios that have been selected make use of frequency hopping to avoid interference from other RF sources. Also, a range check will be performed with the RC handset prior to flight and the RSSI of the telemetry/control link will be checked prior to flight.
 - Flight beyond communication range: The flights for this project will be well within the maximum communication range of the radios.
 - Antenna masking during turns and pitch angles: The aircraft has been constructed using minimal amount of material that would significantly attenuate the signal. The antenna has been placed in a vertical orientation to provide the best possible pattern through pitch and roll maneuvers. Furthermore, the antenna has been placed as far as possible from the flight computers, motor, and payload which might also block the signal during maneuvers.
 - Loss of control station functionality: The control station has the ability to be powered through two different power sources, one of which being an onboard battery to prevent failures from power interruption. Furthermore, if necessary, the ground station can be rebooted if necessary without risk of losing the aircraft should a failure in communications occur.

- Loss of UAS functionality: A redundant control system through a separate radio link has been provided to still allow for manual control in case of the primary communications system failure.
 - Atmospheric attenuation: The selected COTS radios should have sufficient fade margin at the expected flight distances to deal with any atmospheric attenuation.
 - Loss of link: A redundant control system through a separate radio link has been provided to still allow for manual control in case of the primary communications system failure.
 - Loss of visual contact with the UAS: Full status of the system can be determined through the operator interface on the tablet. Furthermore, the aircraft can be commanded to return to the launch location to re-establish visual with the primary pilot.
- What are the potential sources of radio frequency interference within the proposed operating area and how are they monitored, managed, and/or mitigated? Given an ISM frequency is being used, there are several potential consumer based sources of interference that might be present on the range. However, the areas being used are in remote locations making it unlikely that significant interference from these sources will be realized. Furthermore, given the size of the ranges, the fade margin of the radio system should be sufficient to overcome even nearby interference from most COTS devices.
 - What spectrum will be used for the communications? How has the use of this spectrum been coordinated? If not required, under what regulation is the use of the frequency authorized? The COTS radios make use of the 902 to 928 MHz unlicensed ISM band.
 - What type of signal processing and/or link security is employed? The COTS radios make use of a frequency hopping scheme to mitigate interference. 256 bit AES encryption is available on the radio link.
 - For satellite links, estimate the system communications latencies associated with using the satellite link for aircraft control and for ATC communications? N/A
 - What is the data link margin in terms of the overall link budget at the maximum anticipated distance from the control station? How was it determined? The link margin should be around 30 dB for the maximum expected distance of 5 miles from the ground station. This was determined using the radio and antenna specifications as well as an estimate for the cable and connector loss.
 - Does the system employ redundant communications links? If so, how dissimilar are they? Yes, the manual control is performed over a 2.4 GHz frequency hopping radio.
 - Is there a radio signal strength and/or health indicator or similar display to the pilot? How are the signal strength and health value determined, and what are the threshold values that represent a critically degraded signal? The RSSI of the link is available to the

operator, and they are allowed to set the value of the minimum RSSI that will be allowed before the operator is warned about poor link quality.

- Is there an intercommunication system that allows for communication between the pilot(s), ground support personnel, and observers? The pilots, ground support personnel and observers will be co-located.
- What procedures have been established in the event of intercom failure? N/A (see above).

Abnormal Environmental Conditions and the Effects on Aircraft

Icing Conditions

- What indications, if any, does the system provide the UAS pilot concerning the existence of icing conditions? The system does not provide the UAS pilot any indications concerning the existence of icing conditions
- Does the UAS intend to operate in known icing conditions? No
- Describe any icing protection capability of the UAS: None

Flight Equipment

Flight equipment includes the S2 UAS, payload and nose cone, and ground support equipment.

Ground Support Equipment



Figure - (Left to Right) SwiftStation GCS, Samsung Tablet with SwiftTab UI, Manual Handset

Ground systems include:

1. SwiftStation - which is the ground communication relay between the aircraft and the tablet. It can be powered through an A/C plug or the on-board battery.
2. SwiftTab – The tablet computer containing the user interface. The internal battery powers it.
3. Manual Handset – A radio control handset allowing manual control of the aircraft. The internal battery powers it.
4. Launch System – A pneumatic catapult system is used to launch the aircraft. It has been gone through extensive firings (greater than 50) to validate the performance. The maximum pressure in the system is 145 PSI.



Figure - S2 sitting on the pneumatic launcher ready for takeoff.

Ground Control Station

- Describe or diagram the control station configuration. The control station is comprised of three main parts; (1) the ground station, (2) the tablet computer, and (3) the manual handset. The handset allows for manual control of the aircraft and can operate

independently of the ground station and tablet. The manual handset has a button to switch between autonomous control and manual control, allowing the manual pilot to rapidly take control of the aircraft if needed. The ground station acts as a relay between the aircraft and tablet computer. The tablet contains the user interface allowing the pilot to monitor the unmanned aircraft and issue commands.

- How is the control station powered? The control station is powered by an A/C plug with a battery backup that can run for up to 6 hours. The manual handset charge will also be verified prior to deployment. The tablet itself has a run time of over 12 hours from internal batteries but can also be charged from the ground station through a USB port.
- What procedures are in place should the control station lose primary and secondary power? The charge of the ground station battery will be checked prior to any deployment ensuring enough power to run the mission if necessary. In the event of power failure the manual pilot can use the handset to land the aircraft without the ground station. The handset has an audible warning if the batteries get low giving enough to time to land the aircraft. The handset battery charge will also be checked prior to deployment. If either of these control methods indicates low power the aircraft will be landed immediately.
- Does the pilot have a standardized screen set up at the initiation of each phase of flight? The pilot will commence each flight in an orbit plan nearby. The pilot will then be able to send the aircraft on the mission plan by clicking on the first waypoint and selecting "Go to Point" from the drop down menu.
- Are any other programs running on the ground control computer? Other than the standard background processes running on the Android tablet, all other programs will be closed prior to deployment.
- What are the possible conditions that would cause a control position lock-up? Are any of the primary flight controls based on the Microsoft Windows operating system? None, other than a power failure. Microsoft windows is not utilized.
- What alarms or warnings does the system provide to the pilot (for example, low fuel or battery, failure of critical systems, departure from operational boundary)? The system provides the following warnings to the user through red warnings on the user interface.
 - Loss or degraded GPS signal.
 - Low propulsion battery.
 - Low signal strength on the data link.
 - Altitude above or below commanded range.
 - Airspeed above or below commanded range.
 - Engine disabled.

- How accurately can the pilot determine the attitude and position of the UAS? The user interface provides the attitude of the unmanned aircraft accurate to approximately 0.5 degrees in roll, pitch, and yaw in real-time. The position of the aircraft is based on the GPS measurement and is also provided in real-time on the map-based interface.
- What kind of inadvertent input could the pilot enter to cause an undesirable outcome (for example, accidentally engaging the kill engine command in flight)? Disabling the engine inadvertently will alert the user. The aircraft will maintain airspeed by descending slowly. Re-enabling the engine on the interface will allow the aircraft to climb back to the correct altitude. The interface protects the user from other inadvertent commands through mission limits for both altitude and airspeed.
- What is the lag time between command input and execution by the vehicle? There is very little lag, just the time it takes the radio to transmit the message.

Flight Operations Description

Flight envelope and test plans

- Describe the conditions under which flight envelopes will be tested. What is the proximity of flight operations to populated areas, major highways, etc.? The S2 will be flown within the limits of +/- 45 degrees in roll, +25/-15 degrees in pitch and between 29 kts to 48 kts airspeed, with a nominal cruise speed of 37kts. The team will not operate in winds exceeding 20 kts. The launch location and total flight area is in a secluded region that is very sparsely populated.
- Describe how you plan to meet test objectives under the proposed flight envelope and operating area. Include test plans, if possible. By flying the Black Swift S2 with the P-Band radiometer over the instrument test site in the mountains in Colorado.

Operating History

- The operational history of the UAS.
 - The specific aircraft for this campaign has flown a total of 40 flights and 22 hours of flight time.
 - All repairs and modifications are tracked by BST and will include a QC flight test with a mass model following the work.

Crew Members and Operating Procedure

There is full redundancy between pilot and observer - although one person controls the UAS while observing it, the operational plan includes two people - a pilot and an observer. Furthermore, both the pilot and the observer are fully trained for both roles - so if the pilot

becomes incapacitated, the observer has the ability and equal credentials as the pilot to take control of the UAS.

Both the pilot and observer have significantly adequate experience and flight hours. The Pilot in Command has been involved with the operations of unmanned aircraft since 2001 and has operated or manually piloted nearly 1000 hours of operations across 20 or so platforms, 5 different autopilot systems and in difficult situations such as tornado chasing and in the arctic. The flight needs of this mission are far less difficult or complex.

The plan is to perform these operations under the following rules and procedures as follows:

- All flight operations have to comply with the contents of FAA part 107 rules with BVLOS wavier and NASA Armstrong approval.
- A copy of the documentation and licenses will be available to all operational personnel at the operations location.
- The take-off area will be clear of any personnel, debris or obstructions.
- Flight path will be clear with no personnel or obstructions.
- If present, roadways will be blocked off to any traffic (low traffic or no traffic areas have been selected).
- Cones will be placed indicating the area is blocked and additional personnel will be staged to ensure safety at perimeters if necessary.
- The vehicle will remain in line of site for the observer at all times (if it leaves line of sight, it automatically return to within line of sight)
- Documentation of each flight will be maintained in a single notebook.

UAS Crew qualification will be monitored and approved by Armstrong Flight Operations.

Pilot in command will be Jack Elston of Black Swift Technologies who holds a FAA remote pilot license and a current class 3 medical. The observer will be Maciej Stachura, who holds a FAA private pilot license and a current class 3 medical.

National Airspace Integration

- What are the minimum traffic detection capabilities in azimuth and elevation? The aircraft does not possess traffic detection. The observer will scan the sky with the naked eye.
- Describe the procedures that will be implemented should an aircraft enter the operating area? The observer will update the pilot in command of the heading and approximate altitude of the manned aircraft and immediately say any changes. The pilot in command

will initiate immediate landing procedures and if necessary command the unmanned aircraft to a new location to safely avoid a mid air collision.

- A near midair collision is defined as an incident associated with the operation of the unmanned aircraft in which a possibility of collision occurs as a result of proximity of less than 500 ft to another aircraft, or a report is received from a pilot or a crew member stating that a collision hazard existed between two or more aircraft. It is the responsibility of the pilot to determine whether a near midair collision did actually occur and, if so, to initiate a NMAC (near-midair collision) report as outlined in FAA Order 8020.11 and/or in the AIM (aeronautical information manual). Traffic and collision avoidance is governed by FAR Part 91.113. However, UAS procedures generally require the UA to give right-of-way in all cases. The written procedure should describe the appropriate communications and actions for all cases, given that the UA could be operating outside the visual LOS of the PIC.
- Describe the roles and responsibilities of the chase aircraft crew, if one is used, including pilot and observers. N/A.
- Describe any special training the chase aircraft crew will receive. N/A

Flight phases

- Describe the entire flight planning process, including how weather briefings and updates are obtained. Describe what type of flights will be performed. The checklist in Appendix 2 contain the steps from T-1 day through landing. Specifically for the weather, operations will be limited to maximum winds of 20kts and visual flight rules for Class E airspace, specifically:
 - 3 statute miles visibility.
 - Minimum cloud ceiling of 900'.
 - Winds below 20 kts.
- Describe your coordination procedures with ATC before takeoff by addressing the following:
- Notice to Airmen (NOTAM): A NOTAM will be issued 24 hours prior to flight for an unmanned aircraft. The NOTAM will include the area, operating altitudes, and time.
- Filing the flight plan: A flight plan will not be filed for these operations.
- Obtaining transponder codes: No transponder will be used.
- How do you ensure that area is clear for taxi? N/A.

- Are there safeguards to preclude inadvertent engine starts that could cause injury to ground personnel? The engine will be disabled on the interface until right before takeoff.
- Describe UAS preflight activities and the system and support equipment required by addressing the following:
 - The process by which the system is prepared for flight: The preflight steps are written out in Appendix 2.
 - The systems required to prepare the system for flight: The list of equipment is listed in the "equipment" list of Appendix 2.
 - What critical process points are established, such as system configuration files needed to establish flight control calibration? Calibration and configuration files are stored on-board the aircraft. All calibrations and surface deflections are verified prior to flight.
 - Describe how mapping updates are performed on the control station. The pre-flight preparation process is outlined in the pre-flight checklist for both the manual pilot and operator in Appendix 2. As outlined in the checklists, the required systems are the aircraft, GCS, tablet, handset, along with the tools listed in the "equipment" section of the checklists. System configuration files and calibration are stored on the autopilot, ensuring that the same setup is used from one flight to the next. The maps for the operations area are loaded the day before flight using the user interface utility that allows the user to draw a box and save all the map layer types. This ensures that all map types (including the VFR charts) are up to date.
- Describe the flight line/operations safety program, if any. N/A
- Provide a description of system equipment for required takeoff/launch. Identify unique system performance and procedures. The S2 is catapult launched after both the operator and manual pilot complete the pre-flight checklists.
- Identify the components of the system, including support equipment required for the UAS to conduct safe flight operations. Information presented in response to this item should address the following:
 - The process by which the system is operated during flight
 - The systems required to operate the system during flight

Critical process points that are established

- Ground control station: This acts as a communication relay between the aircraft and the tablet computer. The GCS is powered on prior to flight and left on until the conclusion of operations.

- The RC Handset: Used to manually control the aircraft. The battery will be charged prior to deployment and verified according to the “pre-flight” section of the checklists in Appendix 2.
- The tablet computer: This is an Android tablet running the ground control software. Running the software involves simply starting the app and then controlling and monitoring the aircraft. The manual, located at <http://mkdocs.bst.aero/>, contains more detailed descriptions of the use of the software.
- Describe the method for switching between pilot controlled (manual) and autonomous flight modes. At what point during the flight will this happen? The switch between manual and autonomous modes is on the radio control handset that the manual pilot is using. The manual pilot flies the aircraft from takeoff. When they are ready to hand-off to autonomous mode they inform the operator, who qualitatively verifies the state estimate (roll, pitch, yaw, altitude, and airspeed) and then informs the manual pilot to switch modes. Following the conclusion of the flight objectives, the manual operator takes back control of the UAS and lands. During the autonomous flight the manual pilot monitors the aircraft at all times and can take-over manual control at any time if needed.
- What indication does the pilot have that he/she is in control of the UAS? The tablet user interface clearly shows if the aircraft is in manual or autonomous mode.
- How are changes made to the flight plan during flight? The tablet UI allows the user to make changes to the flight plan in real-time by either dragging individual waypoints or entire flights plans that are overlaid on the local map.
- Describe the procedures in the event of lost communications with ATC (if applicable). Communications will not be maintained with ATC throughout the flight except in the event of the aircraft flying out of the COA boundary not under control. In this case ATC will be contacted by phone.
- Provide a description of system equipment required for landing/recovery. Identify unique system performance and procedures. The S2 performs a fully autonomous landing. It has no landing gear but lands on its underside. The landing area will be determined prior to launch and will be of sufficient size to land the S2. The only equipment utilized for landing will be the radio control handset for which the charge will be verified prior to deployment as outlined in the checklists.
- Indicate the parts of the system, including support equipment required for the UAS to conduct safe operations post flight. Including the following information;
 - The process by which the system is operated post flight
 - The systems required to operate the system post flight
 - Critical process points that are established
 - The process for a post flight inspection

- The process for incident/accident reporting.
 - Post flight the system will be immediately powered down and data will be saved from the on-board SD Card. A laptop will be used to download the flight and experiment data. A detailed list of the post flight actions is listed on the "operator" checklist in Appendix 2. Incident/accident reporting is done through the FAA website.
- Operations Conditions

Aircraft will be operated under standard VFR conditions, during daytime, during safe weather. The detailed flight test plan is contained in Appendix 6 and contains the exact locations and waypoints for each of the sampling missions.

- Maneuvers

UAS will perform standard mapping plans and orbit flight plans. Maneuvers will be limited by operational limits of the aircraft.

- Required Instrumentations
- Is the UAS equipped with an operable Mode-C or Mode-S transponder? No
- Can the transponder be operated by the pilot? N/A
- Describe the transponder test procedures. Is it tested and inspected in accordance with the requirements of 14 CFR 91? N/A
- For transponder equipped VFR UAS with automatic pressure altitude reporting capabilities, is it tested and inspected in accordance with 14 CFR 43 Appendices E and F? N/A
- Does the UAS have a high visibility paint scheme that enables other pilots to see and avoid the UAS and enables the observer(s) to obtain and track the UAS? The S2 has a high visibility paint scheme (orange and gray) to aid the observer. Due to the small size it would be difficult for manned aircraft pilots to see it.
- Does the UAS have anti-collision lights? What are the procedures if the lights are inoperative? No.
- How does the pilot communicate with ATC? Handheld radio if available, though the flight area for this deployment will not be in range of any ATC. The crew will have a phone number to the nearest ATC on hand.
- How does the pilot communicate with other users of the airspace? A NOTAM will be issued 24 hours in advance of flight operations to alert other users.
- Describe the communications equipment, including any equipment on the aircraft. N/A

- How does the flight crew communicate with each other? The crew will always be within voice range of one another.
- Describe the method in place for sense and avoid, and if applicable, identify the members of the flight crew who hold this responsibility. The observer will be responsible to monitor the airspace and advise the pilot in command of possible conflicts. The pilot in command will have final responsibility for deconfliction.
- Mission Control Operations

All flights will be performed using planned maneuvers, such that the flight lines are setup to perform a mapping mission using the onboard sensors. All flying will be via line of sight with automated procedures to return the UAS to in-sight if line of sight is lost, and all flight will done at low altitude, low speed, specifically below 400 feet (120 meters) AGL and 19 m/s.

- Mission Rules and Flight Limitations
- No flights will occur prior to Armstrong and JPL approval of all flight, logistics and safety related documents
- Pilot will be current and experienced with the Black Swift system.
- Most FAA Part 107 flight regulations will be adhered to including:
 - Aircraft must weigh less than 55 lbs.
 - Daylight-only operations or civil twilight.
 - Must yield right-of-way to other aircraft.
 - Maximum ground speed of 100 mph (87 kts).
 - Maximum altitude of 400 feet above ground level (AGL) or, within 400 feet of a structure, 400 feet above that structure.
 - Minimum weather visibility of 3 miles from control station and must remain 500 feet from clouds.
 - Operations in Class G airspace.
 - UAS cannot be operated from a moving vehicle unless the operation is over a sparsely populated area.
- A wavier will be obtained for the following FAA Part 107 flight regulations:
 - Aircraft must remain within VLOS of the remote pilot in command and the person manipulating the flight controls of the small UAS.
- Nonstandard Operation or Inspection Criteria

Standard Provisions

1. For this mission, only one unmanned aircraft will be flown at a time. Further, there will only be a single ground station used and a single PIC per mission.
 2. The Pilot-in-Command (PIC) has final authority and responsibility for the operation and safety of flight and the verification the operating area is clear of all non-participating personnel.
- Associated Checklists

Manuals

- Is there an operational manual for the UAS? The autopilot and ground station manual can be found at <http://mkdocs.bst.aero/>.
- Does the manual have a section with all the aircraft limitations in one location? The C.G. limits are marked on the wings and is checked prior to each flight, the airframe will not exceed a Vne of 80kts and payload limit of 5lbs.
- Does the operating manual have bolded or underlined procedures for emergencies for memory item steps? See the document "emergency.pdf" for the list of emergency procedures.
- Is there an operational checklist for all phases of the operation? See the checklists in Appendix 2.
- Are there separate checklist items for normal, abnormal, and emergency procedures? Yes, the checklists in Appendix 2 are for normal procedures and Appendix 5 contain emergency and lost link procedure
- Description of In-Flight Malfunctions or Emergency Conditions

Emergency and flight recovery

- Describe the emergency recovery system, if any. Yes, for emergencies the manual pilot takes over the aircraft with a radio control handset.
- How do you know the emergency recovery system is operational? It is tested prior to take-off.
- Under what conditions is the return home mode both manually and automatically activated? In the event of a lost communication event, the aircraft will automatically return to the lost communication waypoint. Also, the aircraft can be brought back home using the tablet interface at any point in the mission.

- What is the return home point? How is this point selected? How is this point entered? The point is set as an orbit point offset from but near the ground station. It is entered through the tablet UI.
- How does the UAS navigate when in the return home mode? The UAS utilizes the GPS position to navigate home.
- Describe the flight recovery system (FRS), if any? There is no flight recovery system.
- Under what conditions is an FRS manually and automatically activated? N/A
- What happens to the aircraft when the FRS is activated? For example, does the engine run temporarily? Does the UAS glide or become unstable? N/A
- How do you know the FRS is operational? N/A
- Provide a fault tree diagram, starting with the initial condition of normal flight that shows the conditions that will trigger the FRS. N/A
- If activated, can the FRS be turned off/shut down if no longer needed? N/A
- If FRS fails, is there a backup or secondary FRS to ensure no additional hazards are introduced to the operational area? N/A
- Describe how the aircraft will react during takeoff, climb, cruise, descent, and landing in the event of a loss link. In all phases of flight the aircraft will automatically fly to the lost communication waypoint, which is the same as the "return to home" waypoint.
- Describe the operational procedures in the event of a lost link.
 - The SwiftPilot system utilizes a periodic heartbeat from the GCS to ensure that even if the user does not issue commands to the UA, the vehicle should receive packets from the ground. If these packets are not received, the system waits for an operator defined timeout (set to 10s for this mission), and then the autopilot will change to tracking the waypoint number that has been established as the "lost comm waypoint." This waypoint is defined by the operator, and will be sufficiently close to the ground station to allow for re-establishing of communications, while keeping the aircraft at a safe standoff distance in case communications with the aircraft does not return. It is verified during the preflight procedure and a flight will not be allowed by the system if either the waypoint is not present on the aircraft or is too far away from the ground station to re-establish communications. This will also enable the manual pilot to take over the aircraft and initiate landing procedures in the event that the autopilot data link is not re-established. If the time of the lost link event exceeds 5 minutes and the manual pilot has not taken control the aircraft will automatically descend and land at the predetermined location.
 - The manual handset allowing direct user control of the aircraft provides a secondary link. In the event this link is lost while in manual control the on-board

receiver is programmed to automatically switch to autonomous control of the aircraft.

Flight Termination System and Ground Abort

- Does the UAS contain a flight termination system? If so, explain. Flight can be terminated quickly utilizing the manual handset, which is an independent system from the autopilot.
- Is there a procedure for ground aborts? If so, explain. The aircraft is catapult launched so there are no ground operations prior to takeoff.

HAZARD ANALYSIS

Hazard Analysis of Systems and Operations

- Lasers
 - Laser type:
 - Laser class: 1M
 - Laser wavelength: 905nm
 - Output power/energy: <1.2 mW
 - Output power/energy pulse width: 15 ns
 - Output power/energy rep rate: 10 kHz
 - Shielding requirements: None
 - Do you have authorization to operate inside the United States? Yes, a Class 1M laser can be legally operated in the United States.
 - Do you have authorization to operate outside the United States? The laser will not be operated outside of the United States.
 - Note: Attach MSDS's for laser dyes, etc. used in flight or on the ground. TBD
- Radio Frequency Emitters
 - Description: Digi XTend (Autopilot Telemetry and Control)
 - RF Power: 1W

- Frequency Range: ISM 902-928 MHz
- Operational constraints: None
- Installation constraints: Part of the avionics package.
- Do you have authorization from the FCC to operate inside the United States? (Please provide proof): Not required.
- Do you have authorization to operate outside the United States? (Please provide proof): N/A
- Compressed Gases
 - Gas description (mixture/concentration): N/A
 - Cylinder internal volume: N/A
 - Cylinder pressure: N/A
 - Number of cylinders required: N/A
 - How often changed: N/A
- Chemicals (solids & liquids):
 - Description (name, concentration): N/A
 - Total quantity on aircraft and in integration area: N/A
 - Usage/Access (ground only, flight only, ground & flight): N/A
 - Container description: N/A
 - Purpose: N/A
- Radioactive Materials
 - Source: N/A
 - Half-life: N/A
 - Quantity: N/A
- Cryogenics
 - Material description: N/A
 - Container description: N/A
 - Quantity required on flight days: N/A
 - Quantity required on non-flight days: N/A
 - Usage/Access (ground only, flight only, ground & flight): N/A

- Operational constraints: N/A
- Installation constraints: N/A
- Batteries/UPS
 - Battery& UPS description (manufacturer name & model number): 14,000mAh 6 Cell Battery 18650 Pack.
 - Battery type: Lithium Polymer
 - Note: Attach MSDS's for each battery used in flight or on the ground.
- Pressure Vessels (containment vessels, compressor tanks)
 - Description (purpose, contents): N/A
 - Internal volume: N/A
 - Vessel pressure: N/A
 - Installation constraint N/A s:
- Motors/Pumps
 - Description: NA
 - Manufacturer name/model number: NA
 - Motor type (capacitor start, brushless, explosion proof): NA
- Heaters
 - Description (system components, location): N/A
 - Manufacturer name/model number: N/A
 - Maximum temperatures: N/A
 - Comments: N/A
- Power Distribution Equipment (non-UAS outlets, power converters)
 - Description: Custom power supply board built into payload.
 - Manufacturer name/model number: Black Swift Technologies, SMM Power Board v1.0.

Risk Assessment and Risk Reduction Actions Methodology

The following 15 risks listed are based on the experience of the team as the ways that failures could occur in UAS operations. These are categorized into the probability and severity of the failures relating to injury to people and damage to the property. It should be noted that the

aircraft and sensor combined are valued at less than \$50,000, the aircraft is property of Black Swift, and the sensor and associated nose cone are property of USGS.

Table - Hazards and category.

Hazard Titles	Hazard Category	
	Human	Assets
S01: Battery fire	II-E	IV-E
S02: Autopilot loss of control in flight	II-E	IV-E
S03: Loss of vehicle electrical power in flight	II-E	IV-E
S04: Mid-air collision	I-E	I-E
S05: Loss of command and control link in flight	III-D	IV-D
S06: Loss of ground station power	III-D	IV-D
S07: Loss of handset power	III-D	IV-D
S08: Aircraft crash resulting in fire	II-E	III-E
S09: Aircraft leaves boundary	II-E	III-E
S10: Lost GPS	III-D	IV-D
S11: Engine Out	III-D	IV-D
S12: Ground crew member injured by propeller	II-E	IV-E
S13: Structural failure in flight	II-E	IV-E
S14: Inclement weather conditions	IV-C	IV-C
S15: Premature Catapult Launch	II-E	IV-E
S16: Operational Altitude	IV-D	IV-D

Table - Hazardous Conditions.

Hazardous Condition	Causes	Effects	Human	Asset / Mission	Mitigations
S01: Battery Fire	Short circuiting of the main power, a damaged battery.	Aircraft fire resulting in loss of UAS.	II-E	IV-E	Battery packs are fused in the aircraft. For charging, a cell balancing charger is used that includes automatic fault detection to terminate charging. A class D fire extinguisher is included. A battery cell checker is used prior to each flight to validate the health of the pack.
S02: Autopilot loss of control in flight	Failure of autopilot software or hardware in flight.	Inability to fly the aircraft autonomously.	II-E	IV-E	Pre-flight checklists are utilized to verify and validate system health and status before flights. Systems are routinely tested and maintenance logged are kept up to date. Manual pilot has control link, independent of autopilot, to aircraft to take over manual control.
S03: Loss of vehicle electrical power in flight	Failure of onboard voltage regulator.	Aircraft uses backup power, flight is terminated.	II-E	IV-E	Pre-flight checklists are utilized to verify battery voltage before flight. Proper battery charging techniques ensure battery is charged to full capacity. Independent voltage regulators supply the autopilot giving redundancy.
S04: Mid-air collision	Failure to see other aircraft and deviate.	Damage to or loss of both aircraft	I-E	I-E	NOTAMS will be issued to notify other aircraft in operational area. A qualified observer maintains LOS operations. Operation at lower altitudes in remote areas reduces presence of other aircraft.
S05: Loss of command and control link in flight	Damaged or disconnected antenna. Loss of tablet power.	Inability to send commands to autopilot.	III-D	IV-D	Autopilot system follows a pre-programmed lost link procedure which includes automatic return to lost link waypoint, and then automatic landing if no communication is re-establish.
S06: Loss of ground station power	Full discharge of battery.	Inability to send commands to autopilot.	III-D	IV-D	Will result in aircraft following lost link procedures. Multiple independent power sources are utilized including batteries and generator. Manual pilot can use

					handset to take over flight control.
S07: Loss of handset power	Starting a flight with a low handset battery.	Inability to take over manual control.	III-D	IV-D	The autopilot is capable of being manually flown through tablet interface of ground station, providing redundant and independent manual control. Emergency procedures will be followed to safely return to designated landing site and autonomous landing will be performed.
S08: Aircraft crash resulting in fire	Hard impact with the ground due to other failures.	Loss of aircraft due to impact and/or fire.	II-E	III-E	Ground crew will carry fire extinguisher for immediate fire mitigation. Local Fire Department will be notified through 911.
S09: Aircraft leaves boundary	Incorrect setup of flight plans and pre-flight settings.	Aircraft leaves boundary presenting a risk to other aviation.	II-E	III-E	Autopilot pre-programmed with geo-fenced region to ensure flight plans or flight path does not extend past boundary. Aircraft is kept in constal LOS enabling manual pilot to take over control and redirect aircraft flight path.
S10: Lost GPS	Disconnect of GPS antenna inflight or noise/jamming in the environment.	Inability of the autopilot to navigate.	III-D	IV-D	Pre-flight checklist utilized to ensure adequate GPS health and status before flight. Routine maintenance performed to validate cable connection. Aircraft is kept in constant LOS operations, enabling manual pilot to take over flight control to return aircraft safely to landing site.
S11: Engine Out	Failure of the motor, ESC, or propulsion battery.	Inability to maintain altitude resulting in termination of mission.	III-D	IV-D	Battery power is checked prior to flight and flight timers combined with real-time battery voltage tracking are used to ensure flight termination before dead battery. Routine maintenance performed to check motor heath. Pilot-in-command can take over manual command or designate auto landing site.

S12: Ground crew member injured by propeller	Crew members not following procedures to stay clear of propeller.	Injury to crew member.	II-E	IV-E	Only trained and approved crewmembers are allowed to handle aircraft during operations. Flight checklist and procedures are followed to insure proper arming of motor control system.
S13: Structural failure in flight	Fatigue of the airframe structures.	Potential degraded performance or loss of aircraft.	II-E	IV-E	Routine maintenance performed to maintain health of aircraft. Pre-flight checklists followed to detect anomalies before flight. Skilled pilot can take over manual control to direct aircraft under certain failures. Operations in remote areas with low structure and population density to reduce risk of impact to structures, homes, building, and people.
S14: Inclement weather conditions	Rapid and unpredicted change in weather.	Flying aircraft beyond specifications, potentially causing	IV-C	IV-C	Flight operations are performed during clear weather conditions. Flight immediately terminated with approaching weather.
S15: Premature Catapult Launch	Crew member accidentally triggering launcher early.	Aircraft launches prior to checklist completion and does not arm motor.	II-E	IV-E	The preflight process involves having the aircraft in a "Ready-to-launch" state prior to arming the launcher. Also, once the aircraft is on the launcher no one on the flight crew will be permitted to walk in front of it to further reduce risk of injury. If the aircraft is somehow launched early the autopilot will level the wings and glide back down without turning on propulsion.
S16: Operational Altitude	Poor aircraft performance due to high altitude.	Decreased climb performance can cause impact with trees or structures. Reduced flight time.	IV-D	IV-D	A mass model of the payload will be flown at the test site prior to operations with the NASA science payload.

Risk Matrix

The likelihood and consequences of the individual hazards listed in Table 1 are summarized in the following risk matrix with the applied criteria explained below and in Tables 12-13.

Table - Human Safety Hazard Action Matrix (HAM)

	Probability [Pr] Estimations - Humans				
	A: Frequent (Pr > 1e-1)	B: Probable (1e-1 > Pr > 1e-2)	C: Occasional (1e-2 > Pr > 1e-3)	D: Unlikely (1e-3 > Pr > 1e-6)	E: Improbable (1e-6 > Pr)
I: Catastrophic					S04
II: Critical					S01, S02, S03, S08, S09, S12, S13, S15
III: Moderate					S05, S06, S07, S10, S11
IV: Negligible			S14	S16	

	Requires Center Director approval and may require approval by a higher authority. These hazards are defined as "Accepted Risks."
	Risk acceptance requires Center Director approval. These are "Accepted Risks".
	Risk acceptance requires Project/Program Manager approval.

Table - Loss of Asset / Mission Hazard Action Matrix (HAM).

	Probability [Pr] Estimations - Assets				
	A: Frequent (Pr > 1e-1)	B: Probable (1e-1 > Pr > 1e-2)	C: Occasional (1e-2 > Pr > 1e-3)	D: Unlikely (1e-3 > Pr > 1e-6)	E: Improbable (1e-6 > Pr)
I: Catastrophic					S04
II: Critical					
III: Moderate					S08, S09
IV: Negligible			S14	S05, S06, S07, S10, S11, S16	S01, S02, S03, S12, S13, S15

	Requires Center Director approval and may require approval by a higher authority. These hazards are defined as "Accepted Risks".
	Risk acceptance requires Center Director approval. These are "Accepted Risks".
	Risk acceptance requires Project/Program Manager approval.

HAM Severity Classifications

- CLASS I (CATASTROPHIC)

A condition that may cause death or permanently disabling/life-threatening injury, or loss of crew.

- CLASS II (CRITICAL)

A condition that may cause severe/lost time injury or occupational illness.

- CLASS III (MODERATE)

A condition that may cause medical treatment for a minor injury or occupational illness (no lost time).

- CLASS IV (NEGLIGIBLE)

A condition that could cause the need for minor first aid treatment (though would not adversely affect personal safety or health).

Loss of Asset/Mission Hazard/Risk Severity Classifications

- CLASS I (CATASTROPHIC)

A condition that may cause the destruction of facility on the ground, major system, vehicle, termination of project, or loss of the only opportunity for critical data. Recovery/replacement cost equal to or greater than \$2M.

- CLASS II (CRITICAL)

A condition that may cause major loss/damage to facility, system, equipment, flight hardware, vehicle, long term project delay, or loss of major project critical data. Recovery/replacement cost equal to or greater than \$500K, but less than \$2M.

- CLASS III (MODERATE)

A condition that may cause loss of mission (sortie, flight, return-to-base, test shut-down, etc.), loss of minor project critical data, minor loss/damage to facility, system, equipment, or flight hardware. Recovery/replacement cost equal to or greater than \$50K, but less than \$500K.

- CLASS IV (NEGLIGIBLE)

A condition that may cause loss of non-critical data, subject's facility, system, or equipment to more than normal wear and tear. Recovery/replacement cost greater than \$20,000 but less than \$50,000.

HAMs Probability [Pr] Categories

A. Frequent

Likely to Occur Immediately on the order of ($Pr > 10^{-1}$).

Expected to occur often in the life of the program/item.

Expected to be experienced continuously in on-going programs.

B. Probable

Probably will occur on the order of ($10^{-1} > Pr > 10^{-2}$).

Will occur several times in the life of a program/item.

C. Occasional

May occur on the order of ($10^{-2} > Pr > 10^{-3}$).

Likely to occur sometime in the life of a program/item, but multiple occurrences are unlikely.

Controls have significant limitations or uncertainties.

D. Unlikely

Unlikely but possible to occur on the order of ($10^{-3} > Pr > 10^{-6}$).

Unlikely to occur in the life of the program/item, but still possible.

Controls have minor limitations or uncertainties.

E. Improbable

Improbable to occur on the order of ($10^{-6} > Pr$).

Occurrence theoretically possible, but such an occurrence is far outside the operational envelope.

Typically, robust hardware, operational safeguards, and/or strong controls are put in place with mitigation actions to reduce risk from a higher level to an improbable state (probability E).