

**Bigelow Development Aerospace Division, LLC**  
**Exhibit A to FCC Form 442 Application**  
**Question 4: Antenna Information**

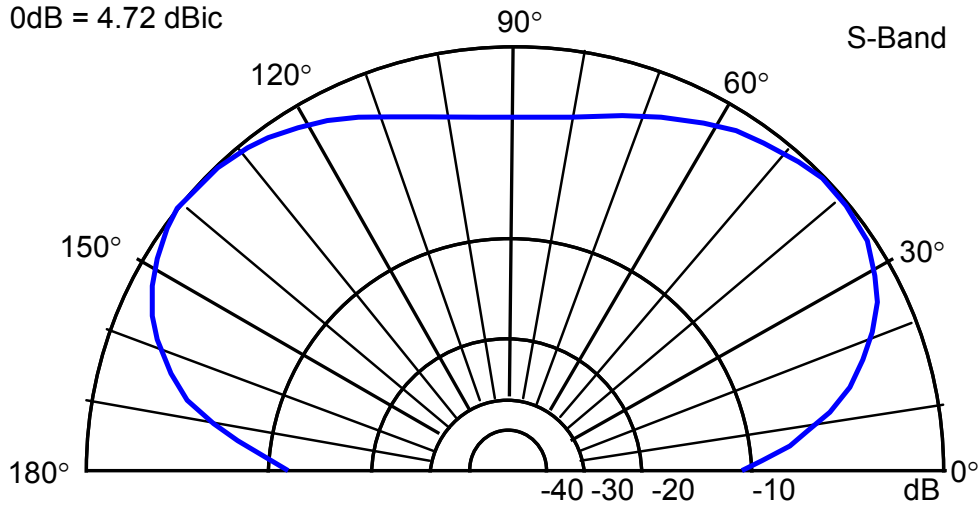

**Figure 1: Space Station S-Band Transmit/Receive**

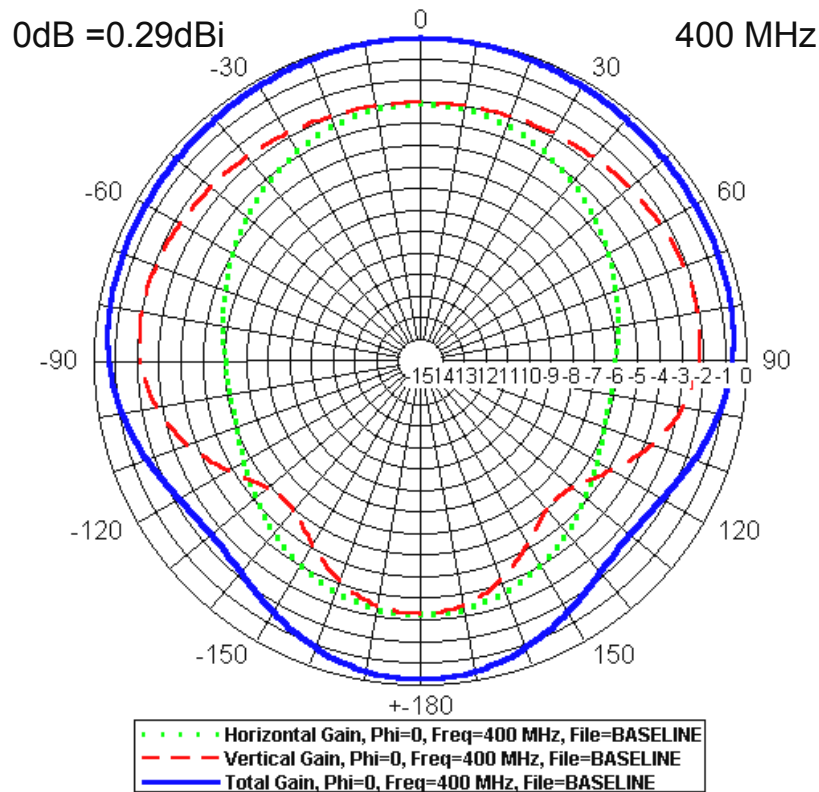

**Figure 3: Space Station UHF Transmit/Receive Antenna**

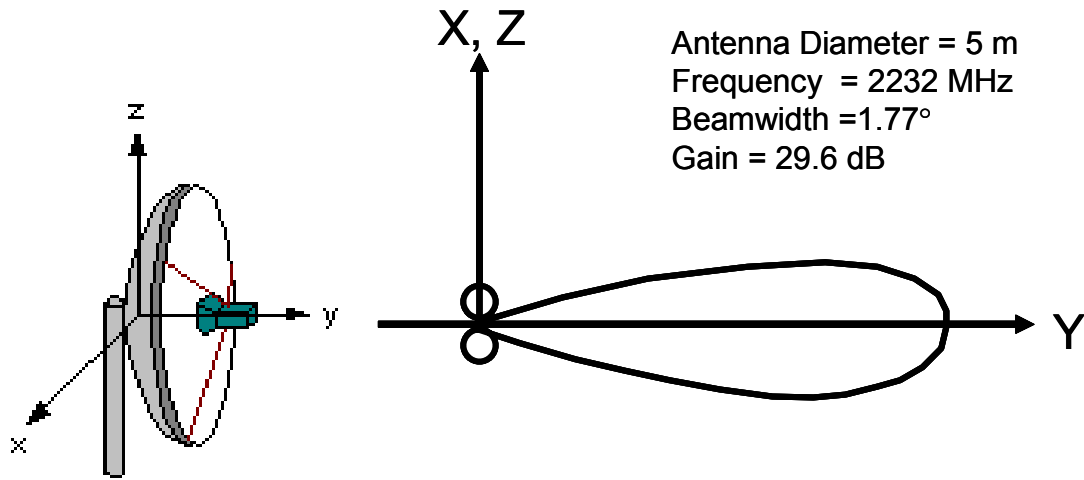

**Figure 2: Earth Station S-Band Transmit/Receive Antenna for Fairfax, VA and Las Vegas, NV.**

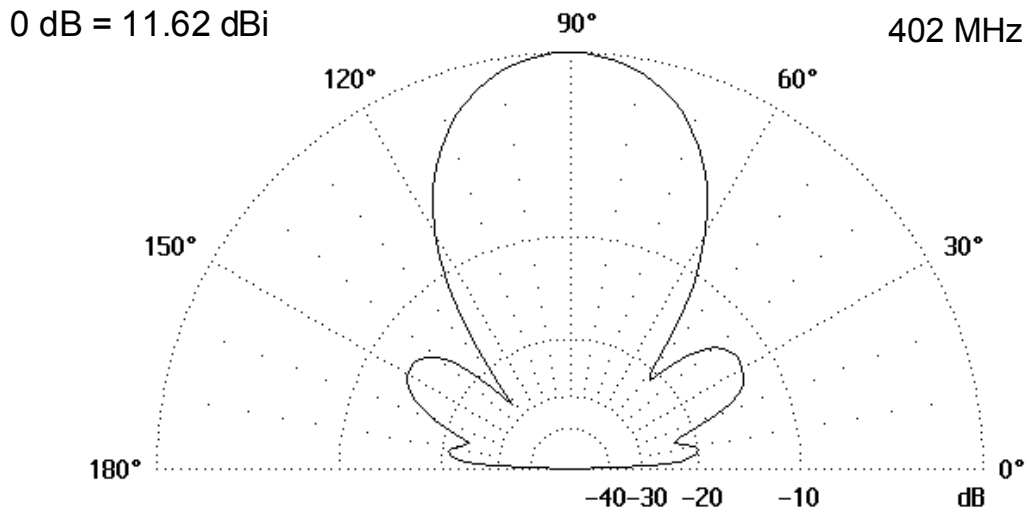

**Figure 4: Earth Station UHF Transmit/Receive Antenna for Fairfax, VA and Las Vegas, NV.**