

AeroCube-7

Orbital Debris Assessment Report (ODAR)

Report Version: 1.3, 14 March 2013

Prepared for NASA in compliance with NPR 8715.6A by The Aerospace Corporation.

Software used in this analysis: NASA DAS v2.0.2

Revision	Date	Pages	Description	Author
1.0	10 Sep 2013	14 + appendices	First version, requires signatures	J. Gangestad, Astrodynamics Dept.
1.1	12 Sep 2013	14 + appendices	Signatures added, minor corrections	J. Gangestad, Astrodynamics Dept.
1.2	14 Feb 2014	15 + appendices	Update for CDR	J. Gangestad, Astrodynamics Dept.
1.3	14 Mar 2014	15 + appendices	Minor corrections from CDR	J. Gangestad, Astrodynamics Dept.
2.0	1 Nov 2014	17 + appendices	Updating for public release	D. Hinkley PICOSAT Program
3.0	1 Sept 2014	16 + appendices	Updated for Formosat5 flight	D. Hinkley PICOSAT Program

VERSION APPROVAL and FINAL APPROVAL*:

The Aerospace Corporation

Dr. Siegfried Janson
AeroCube-7
Principal Investigator
The Aerospace Corporation

Dr. Richard Welle
AeroCube-7
Program Manager
The Aerospace Corporation

Dr. James Nokes
Principal Director
Space Materials Laboratory
The Aerospace Corporation

* Approval signatures indicate acceptance of the ODAR-defined risk.

** Signatures required only for Final ODAR

Self-Assessment of Requirements per NASA-STD 8719.14A

Requirement		Compliance Assessment	Comments
4.3-1a	All debris released during the deployment, operation, and disposal phases shall be limited to a maximum orbital lifetime of 25 years from date of release.	Compliant	AeroCube-7 will release no debris.
4.3-1b	The total object-time product shall be no larger than 100 object-years per mission.	Compliant	AeroCube-7 will release no debris.
4.3-2	For missions leaving debris in orbits with the potential of traversing GEO, released debris with diameters of 5 cm or greater shall be left in orbits which will ensure that within 25 years after release the apogee will no longer exceed GEO-200 km.	Compliant	AeroCube-7 will not operate in or near GEO.
4.4-1	For each spacecraft employed for a mission, the program or project shall demonstrate...that the integrated probability of explosion for all credible failure modes of each spacecraft is less than 0.001.	Compliant	
4.4-2	Design of all spacecraft shall include the ability and a plan to deplete all onboard sources of stored energy and disconnect all energy generation sources when they are no longer required for mission operations or post-mission disposal or control to a level which cannot cause an explosion or deflagration large enough to release orbital debris or break up the spacecraft.	Compliant	
4.4-3	Planned explosions or intentional collisions shall: a) be conducted at an altitude such that for orbital debris fragments larger than 10 cm the object-time product does not exceed 100 object-years, and b) not generate debris larger than 1 mm that remains in Earth orbit longer than one year.	Compliant	AeroCube-7 has no planned explosions or intentional collisions.
4.4-4	Immediately before a planned explosion or intentional collision, the probability of debris, orbital or ballistic, larger than 1 mm colliding with any operating spacecraft within 24 hours of the breakup shall be verified to not exceed 10 ⁻⁶ .	Compliant	AeroCube-7 has no planned explosions or intentional collisions.
4.5-1	For each spacecraft in or passing through LEO, the program shall demonstrate that, during the orbital lifetime of each spacecraft, the probability of accidental collision with space objects larger than 10 cm in diameter is less than 0.001.	Compliant	
4.5-2	For each spacecraft, the program shall demonstrate that, during the mission of the spacecraft, the probability of accidental collision with orbital debris and meteoroids sufficient to prevent compliance with the applicable post-mission disposal requirements is less than 0.01.	Compliant	
4.6-1	A spacecraft with a perigee altitude below 2000 km shall be disposed of by one of the following three methods: a) leave the space structure in an orbit in which natural forces will lead to atmospheric reentry within 25 years, b) maneuver the space structure into a controlled de-orbit trajectory, c) maneuver the space structure into an orbit with perigee altitude above 2000 km and apogee less than GEO-500 km.	Compliant	AeroCube-7 will use natural orbit decay.
4.6-2	A spacecraft or orbital stage in an orbit near GEO shall be maneuvered at EOM to a disposal orbit above GEO.	Compliant	AeroCube-7 will not operate in or near GEO.
4.6-3	For space structures between LEO and GEO, a spacecraft shall be left in an orbit with a perigee greater than 2000 km above the Earth's surface and apogee less than 500 km below GEO, and a spacecraft shall not use nearly circular disposal orbits near regions of high-value operational space structures.	Compliant	AeroCube-7 will not operate in or near MEO.
4.6-4	NASA space programs shall ensure that all post-mission disposal operations to meet the above requirements are designed for a probability of success of no less than 0.90 at EOM.	Compliant	
4.7-1	For uncontrolled reentry, the risk of human casualty from surviving debris shall not exceed 0.0001.	Compliant	
4.8-1	Intact and remnants of severed tether systems in Earth orbit shall meet the requirements limiting the generation of orbital debris from on-orbit collisions and the requirements governing post-mission disposal.	Compliant	AeroCube-7 has no tether system.

NOTE: When manifested for flight, AeroCube-7 will fly as a secondary payload. Compliance with requirements levied by NASA-STD 8719.14A on the launch vehicle will be the responsibility of the primary payload and/or launch provider.

Section 1: Program Management and Mission Overview

Mission Directorate: Space Technology Mission Directorate

Program Executive: Andrew Petro

Principal Investigator: Siegfried Janson, The Aerospace Corporation

Program Manager: Richard Welle, The Aerospace Corporation

Foreign government or space agency participation: none

Nominal Schedule of Mission Design and Development:

Event	Date
Project initiation	1 Oct 2012
System Requirements Review (SRR)	4 Mar 2013
Preliminary Design Review (PDR)	19 Sep 2013
Critical Design Review (CDR)	13 Mar 2014
System integration begins	1 Sept 2015
Test Readiness Review (TRR)	1 Nov 2015
System integration complete	15 Dec 2015
Flight Readiness Review (FRR)	15 Dec 2015
Delivery	15 Jan 2016
Target launch date	1 Mar 2016

Brief Description of the Mission:

The AeroCube-7 is an optical communications and sensor demonstration (OCSD) mission that will address two cross-cutting capabilities of interest to NASA's Small Spacecraft Technology Program (SSTP): demonstration of small-spacecraft proximity operations and high-speed optical transmission of data.

AeroCube-7 has three major mission requirements: first, it will demonstrate an optical downlink of 20-Mbytes over 60-seconds with a bit error rate (BER) of 10^{-4} or better to a 30-cm diameter telescope from low Earth orbit (LEO). Second, it will demonstrate angular tracking of an AeroCube within 50-meter range using an inexpensive optical mouse sensor, and third, demonstrate angular, range, and range rate tracking of an AeroCube using a commercial, off-the-shelf (COTS) lidar sensor. Stretch goals for this mission include demonstration of a 50-Mbps optical downlink, and demonstration of a collision-avoidance maneuver using variable aerodynamic drag.

The flight demonstration will consist of two AeroCube-7s that are ejected from a CubeSat deployer. Each satellite will have an optical communications system rigidly attached to the spacecraft structure to transmit data to the ground, an optical flow sensor, and a lidar range sensor. Technical analyses of the first mission requirement yielded a minimum full-width half-maximum (FWHM) angular beam width for the downlink laser of 1.4 deg using a 14-W downlink laser at 1065-nm wavelength to a 30-cm diameter receive telescope at 900-km range. This downlink laser at 10 W peak output power has been demonstrated in a laboratory breadboard and the receive telescope already exists at Mt. Wilson, California. Required spacecraft attitude control accuracy is half the FWHM angular beam width of 0.35 deg. Figure 1 illustrates one of these AeroCubes sending optical data to the ground.

To meet mission requirements 2 and 3, both spacecraft have to be brought together within 50-meters. This will be accomplished using a combination of coordinated variable atmospheric drag and propulsion. Variable drag will be used to control orbit altitude and spacecraft phasing while the spacecraft are greater than 1-kilometer apart, followed by a combination of variable drag and propulsion for proximity operations.

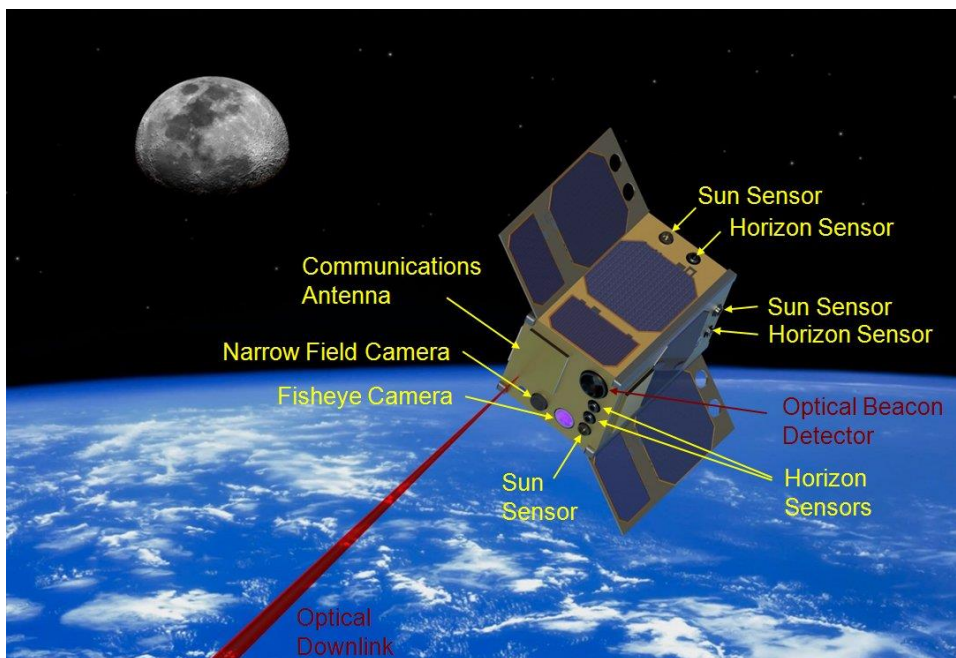

Figure 1. The AeroCube-7 spacecraft with optical downlink beam, assorted sensors, and antenna.

Identification of the anticipated launch vehicle and launch site: AeroCube-7 will fly as a secondary payload on a rideshare mission. AeroCube-7 is currently slated to occupy a P-POD on the upcoming FORMOSAT-5 mission launching in early 2015. This launch will deliver AeroCube-7 to an approximately 420 x 720 km altitude orbit at an inclination of 98 deg.

Identification of the proposed launch date and mission duration: The AeroCube-7 mission anticipates a launch as a secondary payload in early 2016. The mission duration is nominally 180 days.

Description of the launch and deployment profile: As a secondary payload, the AeroCube-7 spacecraft will be deployed from the launch vehicle to minimize risk to the primary payload and upper-stage space structures. Depending on the launch provider, deployment may occur before or after deployment of the primary payload. Typically, after deploying the primary payload, the upper stage performs a small burn to alter the orbit (eliminating the risk of collision with the primary) before releasing any secondary payloads. The AeroCube-7 mission has requested rideshare that will deliver the spacecraft to an average orbit altitude of 450-550 km with an inclination greater than 35 deg.

Reason for selection of operational orbit: The proximity-operations objective of AeroCube-7 relies on differential drag to achieve large-scale in-track stationkeeping and reconfiguration. Below 450 km altitude, the orbit lifetime in the maximum-drag attitude is too short to guarantee 180 days of operations. Above 550 km, atmospheric drag is too weak to provide effective maneuvering capability. The inclination is requested above 35 deg to ensure that the spacecraft pass over The Aerospace Corporation's ground stations in the continental United States.

Identification of any interaction or potential physical interference with other operational spacecraft: The AeroCube-7 mission's optical-communication and proximity-operations objectives require the in-space operation of a laser. All events planned with the AeroCube-7 laser system will be cleared with the United States Air Force Laser Clearinghouse before operation to ensure no undesirable illumination of other operational spacecraft. The mission's proximity-operations objective requires close-range approaches between the two AeroCube-7 spacecraft. The risk of physical interference between the AeroCube-7 spacecraft is discussed in Section 5 of this ODAR. There is no anticipated risk to any other operational spacecraft.

Section 2: Spacecraft Description

Physical Description: The AeroCube-7 mission consists of a pair of one-and-a-half unit (1.5U) CubeSats with dimensions 10 x 10 x 15 cm. Each vehicle has two wings that are deployed on orbit with dimensions of 10 x 15 cm. The wing plane is parallel to the bus diagonal, as depicted in Figure 1. Each satellite contains multiple Sun sensors and Earth sensors, a star tracker, RF communications antenna, GPS receiver, optical-beacon detector, fisheye camera, and narrow-field camera. No components of the spacecraft except the wings extend beyond the dimensions of the 1.5U bus.

Total spacecraft mass at launch: ~2.3 kg

Dry mass of spacecraft at launch: ~2.3 kg

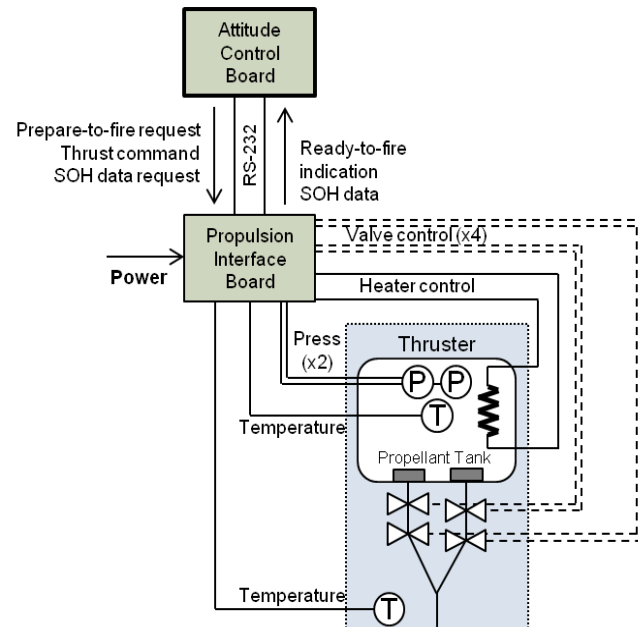

Figure 2. Schematic of the AeroCube-7 warm-gas propulsion system.

Description of all propulsion systems: The AeroCube-7 spacecraft will carry a warm-gas propulsion system utilizing water as a propellant. This propulsion system is a variant of a cold-gas system flown by The Aerospace Corporation on the MEPSI picosatellite, which was deployed by The Space Shuttle on STS-116. The propulsion unit is made of plastic, contains 18 grams of water and presents no explosion hazard.

The AeroCube-7 warm-gas propulsion system uses water as a propellant. This propulsion system provides approximately 2 mN of thrust at an operating temperature of 40 deg C with a specific impulse of 100 s. The propellant tank has a volume of 27 cc and 50% ullage, holding 18g of water that will yield approximately 10 m/s of total velocity change. This system meets CubeSat specifications for on-board propulsion systems, namely it is non-toxic, non-flammable, and operates at less than 1.2 atm of pressure. A schematic of the AeroCube-7 propulsion system appears in Figure 2.

Identification of all fluids planned to be on board: The AeroCube-7 warm-gas propulsion system uses water as a propellant. The water is stored on board in liquid form at a pressure of approximately 0.1 atm. The total mass of water carried by each AeroCube-7 is 18 grams.

Description of all active and/or passive attitude control systems with an indication of the normal attitude of the spacecraft with respect to the velocity vector: Each AeroCube-7 spacecraft has 3-axis attitude control via three magnetic field coils and three “pico” reaction wheels. The rectangular magnetic coils have 125 turns of 32-gauge copper wire and generate a maximum torque of ~5-mN-m at 0.3 Gauss ambient field at 1.1-W. These are area-modified versions of the coils on AeroCube-5. The pico reaction wheels have flight heritage on three AeroCube-4 and two AeroCube-5 spacecraft. Attitude sensors include eight infrared thermometer arrays on various spacecraft surfaces, two-axis sun sensors on various spacecraft surfaces, a 3-axis magnetometer in the main body, a 3-axis magnetometer on a deployed wing, and two or more experimental star trackers. A high-accuracy 3-axis rate gyro will be used to provide an inertial attitude reference when 0.7 deg or better pointing accuracy is required and the sun and Earth are not simultaneously visible by an appropriate sensor, and a medium-resolution 3-axis rate gyro and 3-axis magnetometer will serve as a backup.

Analyses have shown that the maximum separation between both spacecraft, one month after ejection, could be as high as 1500-km, and a worst-case 3-cm/s separation velocity in the in-flight or anti-flight directions at ejection into a 500-km altitude circular orbit will generate a 240-km range between spacecraft after one month. Therefore, active attitude control will be necessary to ensure control of the in-track configuration of the two AeroCube-7 vehicles. Tumbling behavior is insufficient to meet all mission requirements.

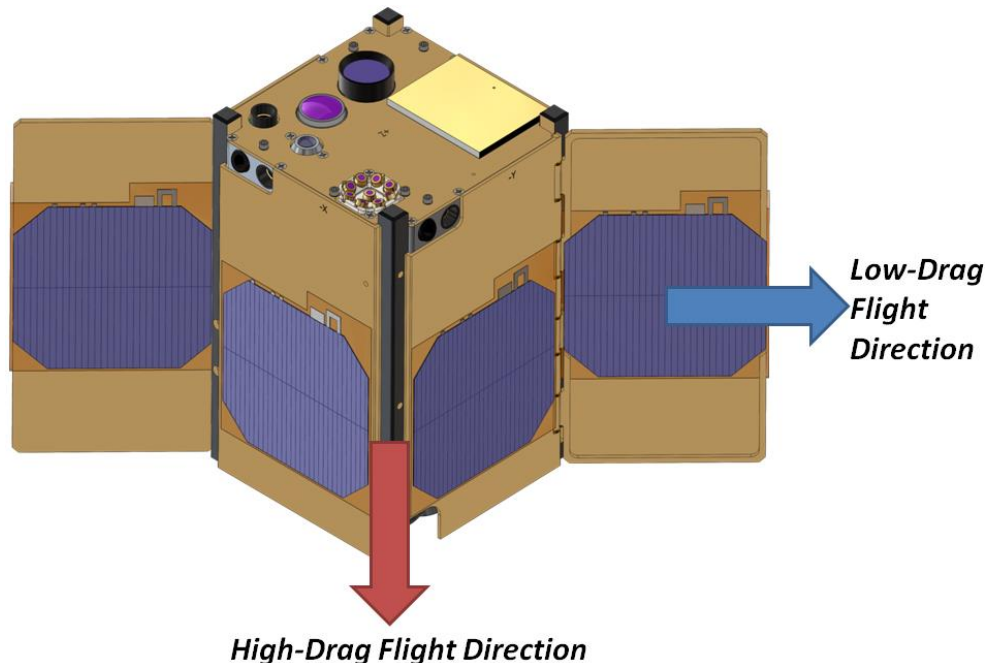

Figure 3. Orientation of AeroCube-OCSD in low- and high-drag attitude modes.

When both spacecraft are in a desired relative configuration, the nominal attitude of both spacecraft will be a “low-drag” mode, where the intermediate cross-section of both spacecraft is aligned with the velocity vector, as shown in Figure 3. By having both spacecraft hold in low-drag mode, the differential drag will be nearly zero, thereby maintaining the desired configuration, and the absolute drag will be the lowest possible for the vehicles, minimizing the rate of orbital decay.

During periods of constellation reconfiguration, differential drag (and subsequent in-track relative motion) requires one AeroCube-7 vehicle to be in low-drag mode while the other is in “high-drag” mode, where the largest cross-section of the spacecraft is aligned with the velocity vector, as shown in Figure 3. High-drag mode may be maintained for several days to induce the desired in-track drift before returning to the nominal low-drag mode.

Description of any range safety or other pyrotechnic devices: AeroCube-7 has no pyrotechnic devices.

Description of the electrical generation and storage system: Power for AeroCube-7 is generated by solar cells mounted on four faces of the spacecraft bus and on the two extended wings. These cells are capable of producing up to 16 W of power. Solar energy is stored on-board by the bus lithium-ion bus batteries with 18 W-hr capacity. A second battery that is used to control the on-board laser also consists of two cells with a total energy storage capacity of 12 W-hr. Specific details of the batteries’ manufacture appear in Section 4.

Identification of any other sources of stored energy: There no other sources of stored energy on AeroCube-7.

Identification of any radioactive materials on board: AeroCube-7 carries no radioactive materials.

Section 3: Assessment of Spacecraft Debris Released during Normal Operations

Identification of any object (>1 mm) expected to be released from the spacecraft any time after launch: AeroCube-7 will release no objects into space during normal operations.

Rationale/necessity for release of each object: N/A

Time of release of each object, relative to launch time: N/A

Release velocity of each object with respect to spacecraft: N/A

Expected orbital parameters (apogee, perigee, inclination) of each object after release: N/A

Calculated orbital lifetime of each object, including time spent in LEO: N/A

Assessment of spacecraft compliance with Requirements 4.3-1 and 4.3-2:

Requirement 4.3-1a: COMPLIANT

Requirement 4.3-1b: COMPLIANT

Requirement 4.3-2: COMPLIANT

Section 4: Assessment of Spacecraft Intentional Breakups and Potential for Explosion

Identification of all potential causes of spacecraft breakup during deployment and mission operations: There is no credible scenario that would result in spacecraft breakup during normal deployment and operations.

Summary of failure modes and effects analyses of all credible failure modes which may lead to an accidental explosion:

Battery risk: A possible malfunction of the lithium ion or lithium polymer batteries or of the control circuit has been identified as a potential, but low probability, cause of accidental breakup or explosion. Natural degradation of the solar cells and batteries will occur over the post-mission period and poses an increased chance of undesired battery-energy release. The battery capacity for storage will degrade over time, possibly leading to changes in the acceptable charge rate for the cells. Individual cells may also change properties at different rates due to time degradation and temperature changes. The control circuit may also malfunction as a result of exposure over long periods of time. The cell pressure relief vents could be blocked by small contaminants. Any

of these individual or combined effects may theoretically cause an electro-chemical reaction that results in rapid energy release in the form of combustion.

Notwithstanding these potential sources of energy release, AeroCube-7 still meets Requirement 4.4-2 as the on-board batteries cannot “cause an explosion or deflagration large enough to release orbital debris or break up the spacecraft.” The batteries used on AeroCube-7 are certified by Underwriters Laboratories (UL). In general, these batteries are similar in size and power to cell-phone batteries.

CubeSat Name	Model Number (UL Listing)	Manufacturer	Number of Cells	Energy Stored per Cell
AeroCube-7	ICR18650H	Molicel	2	<9 W-hr
AeroCube-7	IBR18650BC	Molicel	2	<6 W-hr

The batteries are all consumer-oriented devices. The batteries have been recognized as UL tested and approved. UL recognition has been determined through the UL Online Certifications Directory, which clearly shows that these cell batteries have undergone and passed UL Standards. Furthermore, safety devices incorporated in these batteries include pressure release valves, over-current charge protection, and over-current discharge protection.

The fact that the AeroCube-7 batteries are UL recognized indicates that they have passed the UL standard testing procedures that characterize their explosive potential. Of particular concern to NASA is UL Standard 1642, which specifically deals with the testing of lithium batteries. Section 20 Projectile Test of UL 1642 subjects the test battery to heat by flame while within an aluminum- and steel-wire-mesh octagonal box, “[where the test battery] shall remain on the screen until it explodes or the cell or battery has ignited and burned out” (UL 1642 20.5). To pass the test, “no part of an exploding cell or battery shall penetrate the wire screen such that some or all of the cell or battery protrudes through the screen” (UL 1642 20.1).

It is reasonable to expect the batteries on AeroCube-7 to experience similar conditions during their orbital life span. While the sources of failure would not be external heat on orbit, analysis of the expected mission thermal environment shows that given the low power dissipation for CubeSats, the batteries will be exposed to a maximum temperature well below their 212 deg F safe operation limit. Continual charging with 2 to 6 W average power from the solar panels over an orbital life span greater than 12 years may expose the batteries to overcharging, which could cause similar heat to be generated internally. Through the UL recognition and testing, it has been shown that these batteries do not cause an explosion that would cause a fragmentation of the spacecraft.

In addition to the aforementioned certification of the AeroCube-7 batteries against explosion, ten potential failure modes for lithium batteries and their applicability or mitigation in AeroCube-7 are addressed in the following table:

	Failure Mode	Applicability or Mitigation
1	Internal short circuit	The AeroCube-7 body and internal design prevents deformation or crushing of the batteries that could lead to internal short circuit.
2	Internal thermal rise due to high load discharge rate	See Failure Mode #4.
3	Overcharging and excessive charge rate	The battery cells on AeroCube-7 have charge interrupt devices that activate during cell internal pressure buildup (due to cell internal chemical that forms a gas) that occurs during overcharging conditions.
4	Excessive discharge rate or short circuit due to external device failure	The bus batteries have an internal positive temperature coefficient (PTC) device that acts as a resettable fuse during external short circuit that limits the cell output current during such an event. The laser (i.e., payload) batteries are of mixed-spinel chemistry and do not have such an internal device due to their high-rate capability; they have been tested in the lab to verify no cell rupture, venting, fire, or explosion occurs during external short circuit conditions.
5	Inoperable vents	Vents have access through the structure that holds them and into the larger satellite volume. Venting will not be inhibited by physical obstructions.
6	Crushing	Satellite body and internal design prevent loads on battery cases.
7	Low level current leakage or short circuit through battery pack case or due to moisture-based degradation of insulators	Satellites are stored in a controlled environment.
8	Excess temperatures due to orbital environment and high discharge combined	Thermal sensors on the batteries provide telemetry on battery temperature. There is no cutoff for overheating batteries except whatever is inherent in the cell itself. However, as noted earlier in this section of the ODAR, the batteries on AeroCube-7 are UL-certified as non-explosive in over-heating scenarios.
9	Polarity reversal due to over-discharge	A 2.7 V discharge cutoff threshold circuit in AeroCube-7 has been verified in acceptance tests for the electric power system.
10	Excess battery temperatures due to post-mission orbital environment and constant overcharging	The circuit that charges the batteries cannot exceed 4.1 V and therefore will never overcharge the batteries.

Through a combination of UL certification, compliance with AFSPCMAN 91-710 V3 requirements, and an understanding of the general behavior of the failure modes associated with these types of batteries, it is possible to conclude that the batteries meet Requirement 4.4-2.

Propulsion-system risk: The warm-gas propulsion system aboard AeroCube-7 presents no explosion risk. However, the water in the tank could freeze and rupture the tank. To mitigate this risk, the propellant tank ullage is limited to 90%. In the event of freezing, the low coefficient of expansion of the propellant (water) ensures that there is ample volume for the ice to occupy. In the case of high temperature, the pressure vessel in the propulsion unit is designed to

withstand the water-vapor pressure at anticipated temperature extremes; furthermore, the design incorporates a pressure relief valve and pressure sensor on the unit. Pressurized thermal tests will occur in a location where an explosion will not cause damage or injury.

Detailed plan for any designed breakup, including explosions and intentional collisions: AeroCube-7 has no plans for intentional breakups, explosions, or collisions.

List of components which are passivated at EOM: Before EOM, AeroCube-7 will deplete any remaining propellants from its warm-gas propulsion system. However, as described above, failure to deplete propellant does not risk explosion or debris-producing events. No other systems on AeroCube-7 will be passivated at EOM.

Rationale for all items which are required to be passivated, but cannot due to their design: As described above, the batteries do not present a debris-generation hazard per Requirement 4.4-2, and in the interest of not increasing the complexity of the AeroCube-7 power system, it was decided not to passivate the batteries at EOM.

Assessment of spacecraft compliance with Requirements 4.4-1 through 4.4-4:

Requirement 4.4-1: COMPLIANT

Requirement 4.4-2: COMPLIANT

Requirement 4.4-3: COMPLIANT

Requirement 4.4-4: COMPLIANT

Section 5: Assessment of Spacecraft Potential for On-Orbit Collisions

Collision probabilities have been calculated using DAS v2.0.2 with the assumptions: 420 x 720 km altitude, 98 deg inclination, 2.3 kg mass (initial and final), and 0.008 m²/kg area-to-mass ratio (the maximum drag configuration).

Calculation of spacecraft probability of collision with space objects larger than 10 cm in diameter during the orbital lifetime of the spacecraft: Probability = 0.00000, per DAS v2.0.2

Calculation of spacecraft probability of collision with space objects, including orbital debris and meteoroids, of sufficient size to prevent post-mission disposal: Because the mission has selected natural de-orbit (see Section 6) for disposal and no systems will be passivated at EOM (see Section 4), small debris do not pose a threat to prevent post-mission disposal.

In addition to the collision danger posed by other vehicles, the AeroCube-7 mission includes a proximity operations phase where both spacecraft will approach each other, via differential drag and on-board propulsion, within 100 meters to perform imaging and lidar experiments. This rendezvous and proximity operations (RPO) process includes collision risk, and the current RPO CONOPS has taken several steps to mitigate this risk. A complete description of the preliminary RPO CONOPS is attached to this ODAR as an appendix and describes the step-by-step plan for RPO. In particular, the CONOPS has been designed to minimize risk to both AeroCube-7 vehicles and to build maximum confidence via incremental testing of maneuver schemes. In particular:

A “dress rehearsal” of all maneuvers will be performed at a staging point—at a safe distance from the other AeroCube—to characterize control authority.

All maneuvers are small (~10 mm/s) and performance will be verified via high-fidelity orbit determination before another is commanded. Furthermore, these maneuvers are small enough so that, even if they were erroneously performed in the most deleterious direction possible, the subsequent motion of the spacecraft would not endanger the other.

An out-of-plane component of the relative motion between the AeroCubes is always maintained, thereby ensuring that the “chaser” AeroCube *never* crosses the path of the target. That is, the chaser vehicle “corkscrews” around the line of motion of the target, preventing collision.

During RPO, the relative velocity between the two AeroCubes does not exceed 1 m/s (2 mph). At this speed, a collision would not cause a catastrophic breakup of either vehicle or create debris.

Examples of the planned maneuvers, including the “corkscrew” RPO, and a discussion of collision risk mitigation appear in the attached appendix.

Assessment of spacecraft compliance with Requirements 4.5-1 and 4.5-2:

Requirement 4.5-1: COMPLIANT

Requirement 4.5-2: COMPLIANT

Section 6: Assessment of Spacecraft Postmission Disposal Plans and Procedures

Description of spacecraft disposal option selected: The AeroCube-7 mission has selected atmospheric reentry for disposal. The vehicle is a 10 x 10 x 15 cm bus with two extended wings of dimension 10 x 15 cm aligned with the bus’s diagonal (see

Figure 3). Each vehicle’s mass is approximately 2.3 kg. The longest possible orbital lifetime occurs if the vehicle were permanently aligned with the smallest face pointing in the direction of

motion, with a cross-sectional area of 100 cm². Although in practice after EOM the vehicle will tumble with a higher “average” cross-sectional area, the analysis in DAS assumed the worst-case low-drag configuration for lifetime. DAS evaluates a lifetime of 8.81 yr, using the orbit assumptions listed at the beginning of Section 5 (except for using a lower area-to-mass ratio). This lifetime is compliant with ODAR requirements.

Identification of all systems or components required to accomplish any post-mission disposal operation, including passivation and maneuvering: As discussed in Section 4, no disposal or passivation is planned for AeroCube-7. Natural orbit decay is sufficient to terminate the mission.

Plan for any spacecraft maneuvers required to accomplish post-mission disposal: None

Calculation of area-to-mass ratio after post-mission disposal, if the controlled reentry option is not selected: N/A

Preliminary plan for spacecraft controlled reentry: N/A

Assessment of compliance with Requirements 4.6-1 through 4.6-4:

Requirement 4.6-1: COMPLIANT

Requirement 4.6-2: COMPLIANT

Requirement 4.6-3: COMPLIANT

Requirement 4.6-4: COMPLIANT

Section 7: Assessment of Spacecraft Reentry Hazards

Detailed description of spacecraft components by size, mass, material, shape, and original location on the space vehicle, if the atmospheric reentry option is selected: The AeroCube-7 vehicles are primarily constructed of aluminum and PCB electronic board material. The only components with a higher density or resistance to melting are stainless steel screws, ceramic path antennas, and three small stainless steel reaction wheels. The spacecraft components used in the DAS 2.0.2 analysis are shown in Table 1. The DAS analysis shows these materials pose no risk per the ODAR requirement.

Table 1. Spacecraft Components used for DAS 2.0.2 Analysis

Description	Shape	No. Used (Per Satellite)	Material	Dia or Width (m)	Length (m)	Height (m)	Mass ea. (grams)	Area/Mass
Laser Assembly	Plate	1	Aluminum/Various	0.102	0.103	0.019	498	0.0096
Body with no wings	Box	1	Aluminum	0.100	0.150	0.100	1000	0.0133
Camera Lens	Cylinder	1	Aluminum/Glass	0.032	0.039	-	80	0.0122
Reaction wheel	Cylinder	3	Stainless	0.012	0.009	-	7	0.0154
Battery	Cylinder	4	Stainless	0.018	0.065	-	48	0.0147
STIM	Box	1	Aluminum	0.039	0.045	0.021	52	0.0228
Lid Assembly	Plate	2	Aluminum	0.102	0.108	0.010	187	0.0234
Wing Assembly	Plate	2	Aluminum	0.079	0.150	0.025	55	0.1064

Summary of objects expected to survive an uncontrolled reentry: The higher-risk materials mentioned above have flown or will fly on several AeroCube missions, including AeroCube-4, AeroCube-5, and AeroCube-6. A DAS 2.0.2 analysis shows these materials pose no risk per the ODAR requirement.

Calculation of probability of human casualty for the expected year of uncontrolled reentry and the spacecraft orbital inclination: Zero

Assessment of spacecraft compliance with Requirement 4.7-1:

Requirement 4.7-1: COMPLIANT

Section 8: Assessment for Tether Missions

The AeroCube-7 mission has no tether. All requirements are COMPLIANT.

Sections 9–14: Assessment of Launch Vehicle Debris

AeroCube-7 will fly as a secondary payload. Assessment of launch-vehicle debris is the responsibility of the primary payload. These sections are N/A for AeroCube-7.