

El Segundo antenna Beam Characteristics and FAA sketch

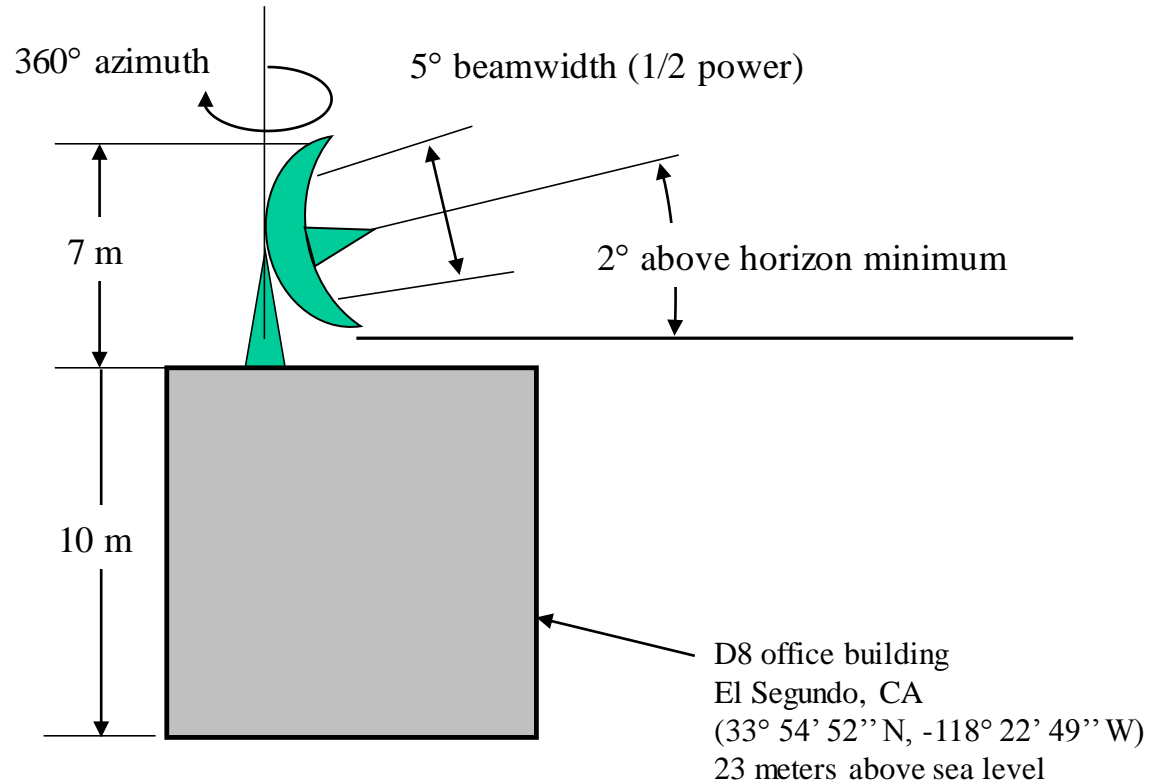

Texas A&M antenna

Beam Characteristics and FAA sketch

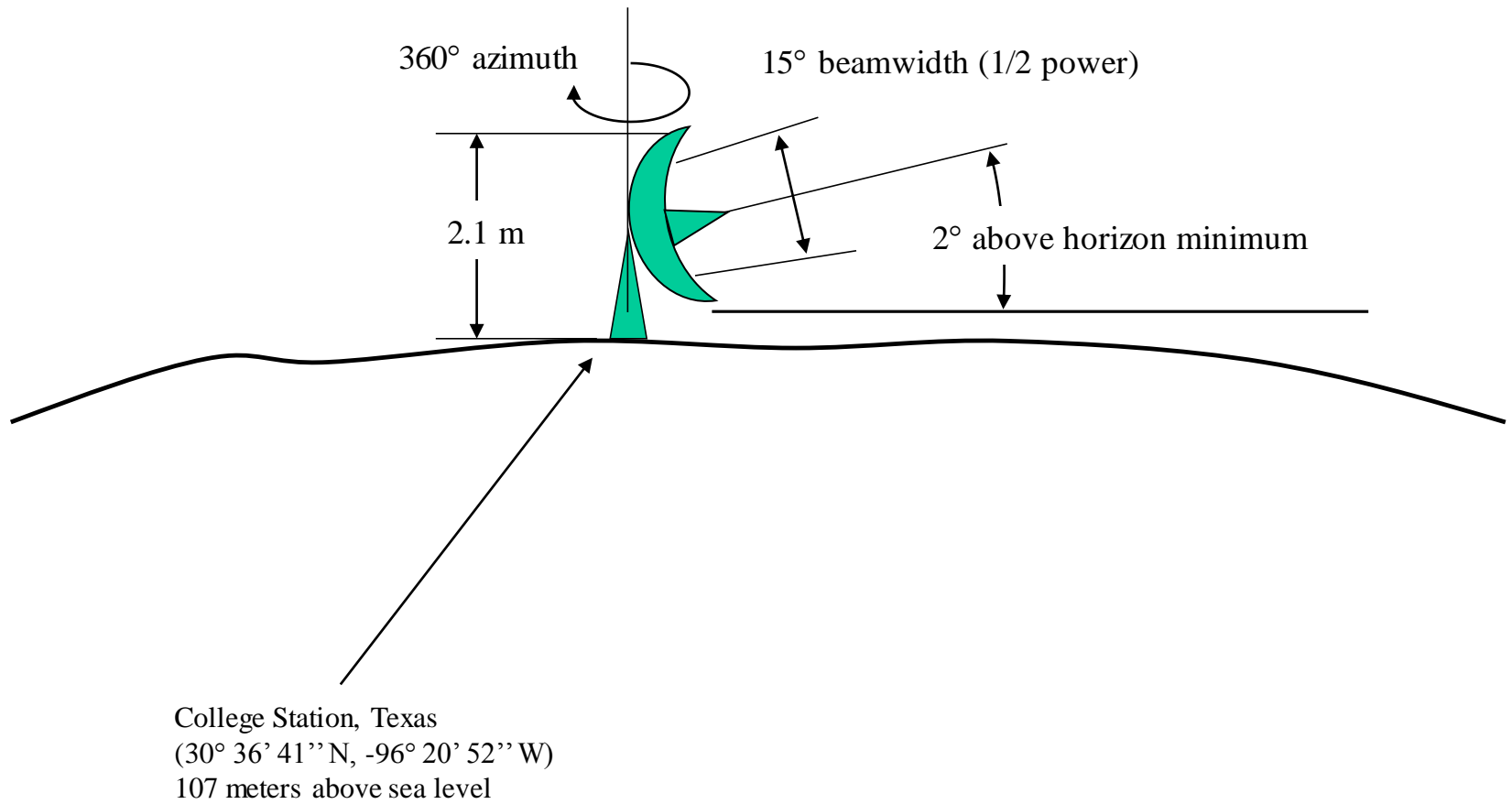

University of Florida antenna Beam Characteristics and FAA sketch

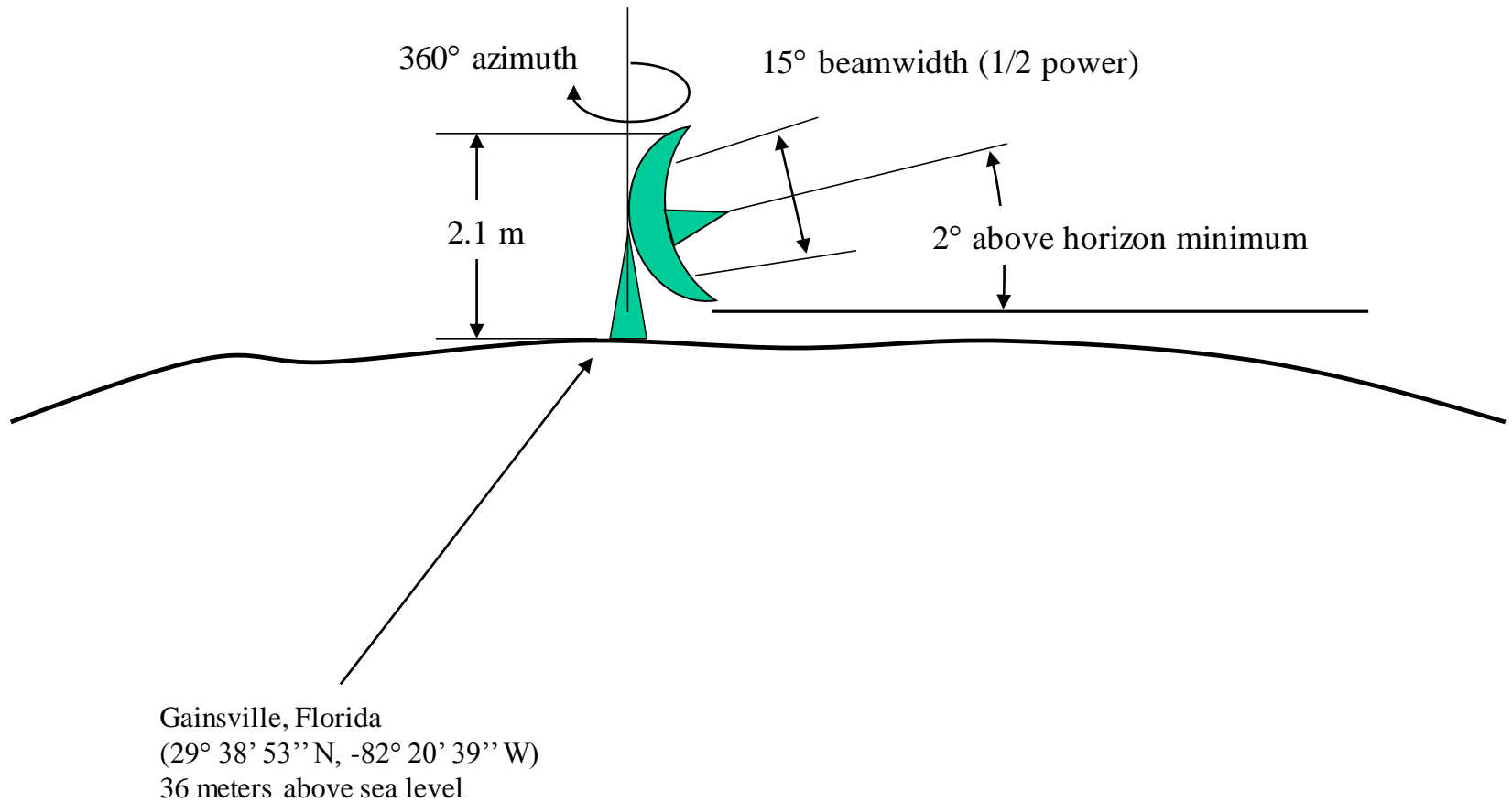

University of Hawaii, Manoa Campus, Honolulu, HI

Beam Characteristics and FAA sketch

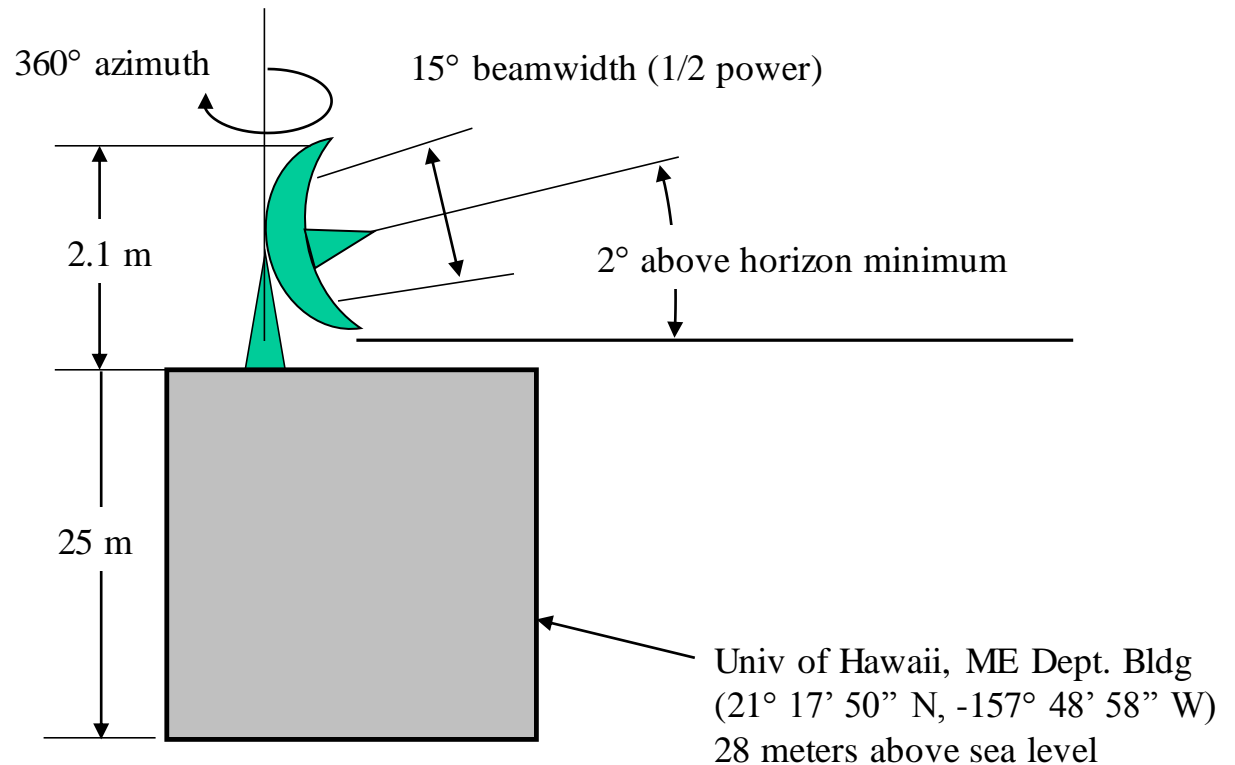

Mt. Wilson, CA

Beam Characteristics and FAA sketch

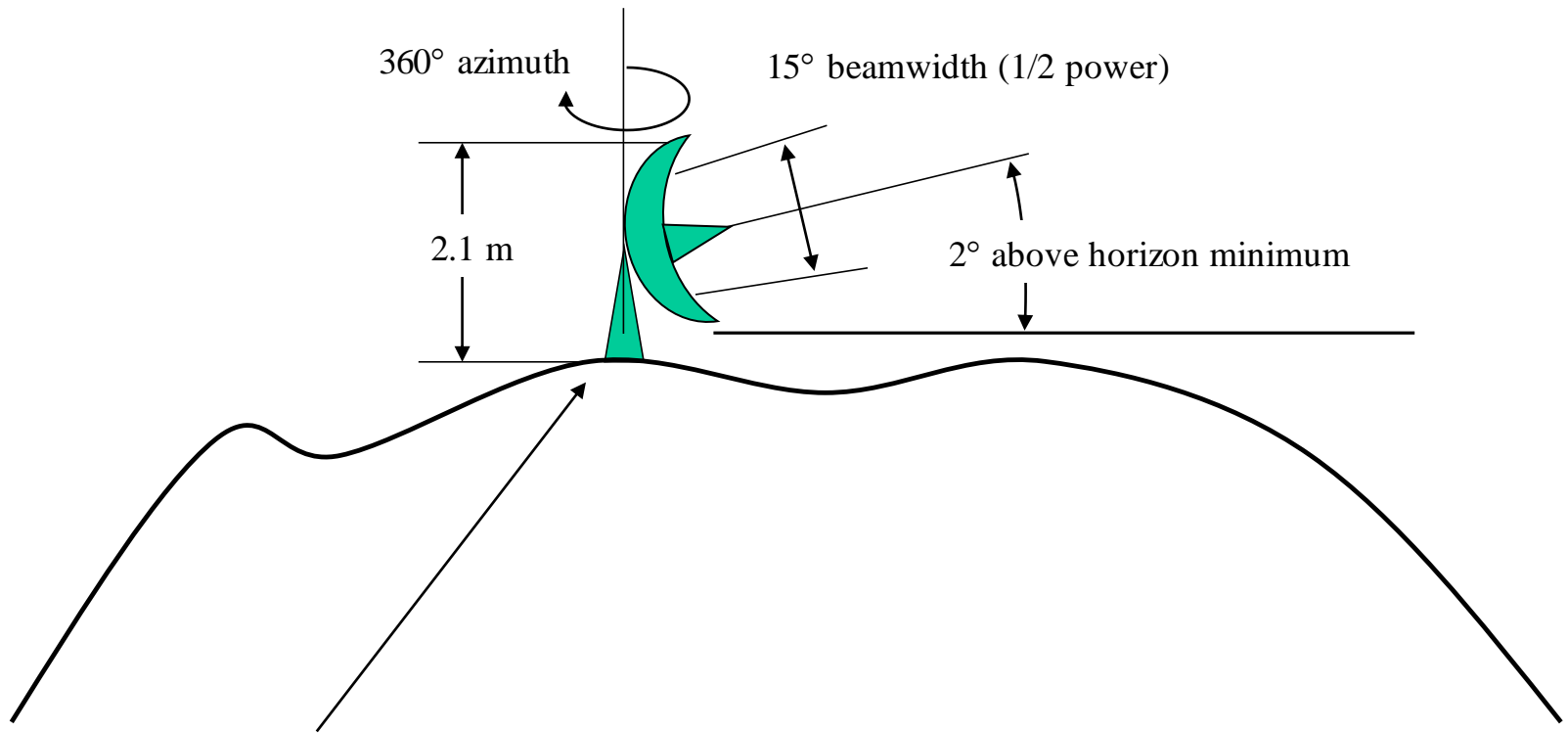

Mt. Wilson Observatory
Mt. Wilson, CA
(34° 13' 29" N, -118° 3' 23" W)
1736 meters above sea level

USAF Base, Vandenberg, CA

Beam Characteristics and FAA sketch

