

ANTENNA AND RADIO DATA SHEETS
5040.8825 MHz and 5040.9675 MHz

Link Type	LOS CNPC	Air Antenna	Ground antenna
Phase	FT & Operational		
Manufacturer	Harris	Haigh-Farr	Southwest Antennas
Model #	CNPC-Radio System	BN1-13110	Part # 1055-034 Broadband Panel Antenna,
Technical			
Length	4.297 in		
Width	2.450 in		
Height	0.945 in		
Weight	212 gram		
Input Voltage	8 - 18 VDC		
Power consumption (W)	6		
Operating temp	-40C to +100C		
Storage Temp			
Frequency range	Harris covers 5040 - 5090		
Frequency (MHz)	5050		
FCC ID:			
Emissions Designator	85K0G2D		
Frequency 'owner'	FAA/FCC need STA		
minimum wavelength (m)	0.059		
RF output power(w)	2.5		
RF output power (dBm)	33.98		
Waveform	TDMA		
Rx Sensitivity conditions	85 Khz, 20 Kbps		
Rx Sensitivity (dBm)	-107		
Air Antenna Gain	0		

Ground Antenna Gain	15		
---------------------	----	--	--

Features:

- Broad Band Coverage
- 4.4 - 5.9 GHz
- 15 dBi
- Designed for C Band communication in the following markets:
 - Law Enforcement
 - Surveillance
 - UAV & UGV Ground Stations



Antenna Specifications

Parameter	Value	Units	Tolerance
Antenna Pattern	Directional Antenna		
Frequency Band	C		
Impedance	50	Ohms	
Minimum Frequency	4.4 / 4,400	GHz / MHz	
Maximum Frequency	5.9 / 5,900	GHz / MHz	
Frequency Bandwidth	1.5 / 1,500	GHz / MHz	
Maximum VSWR	1.5:1	Ratio	15 dB Return Loss
Gain	15	dBi	
Polarization	Vertical		
Maximum RF Input Power	50	Watts	
Horizontal (AZ) Beamwidth	55	Degrees	
Vertical (EL) Beamwidth	32	Degrees	

Parameter	Value	Units	Tolerance
Ground Plane Required	No		
Color	White		
Mount Style	Panel		
RF Connector Type	Type-N(f)		
IP Rating	IP64 when RF connectors are terminated with mating connectors		
Operating Temperature Range	-40 to +185	°F	(-40 to +85 °C)
Product Length	10.180 / 258.572	inches / mm	±0.13"
Product Width	7.180 / 182.372	inches / mm	±0.13"
Product Height	2.830 / 71.882	inches / mm	±0.13"
Product Weight	16.00 / 453.59	oz / grams	

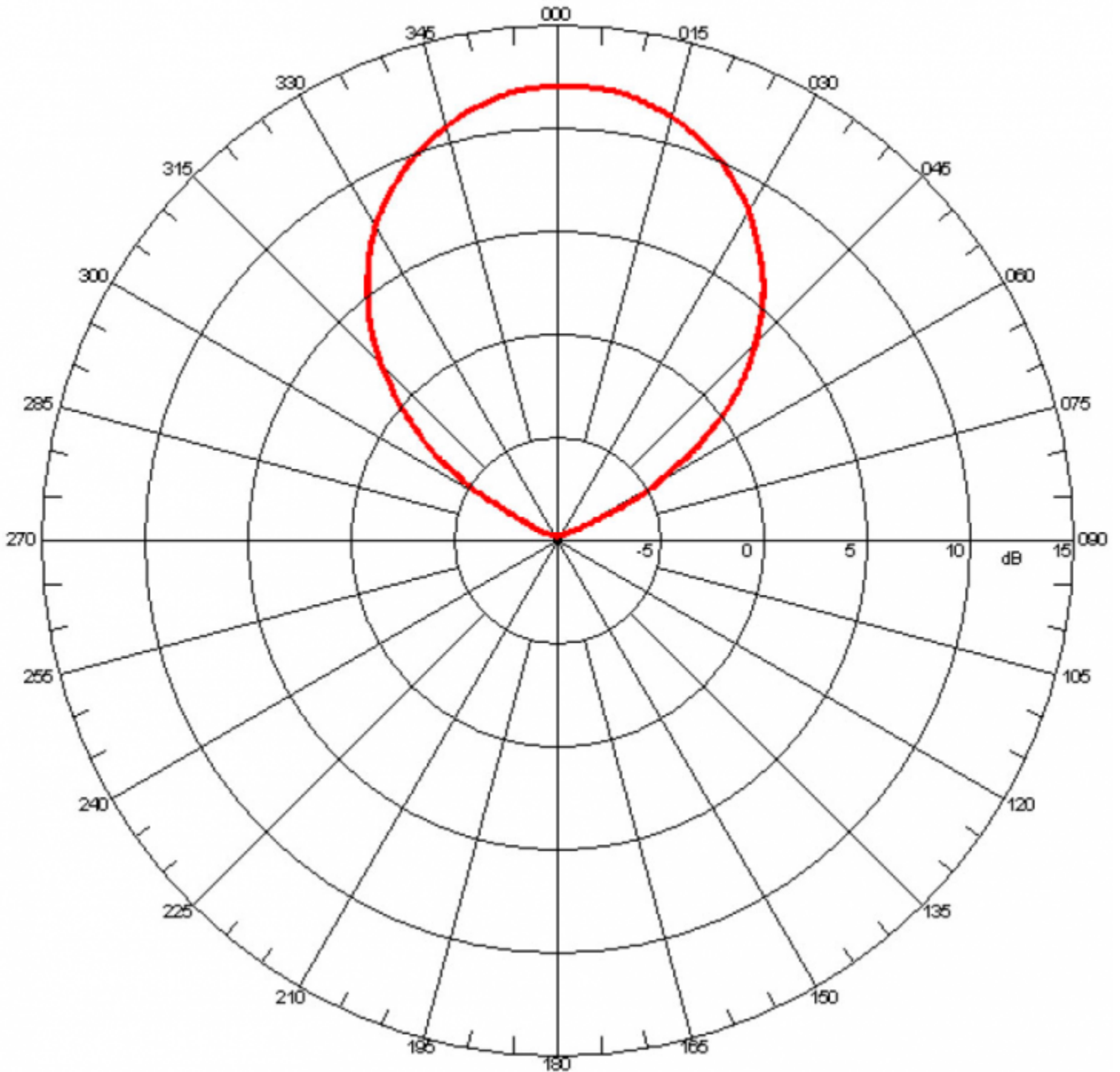

Azimuth Pattern

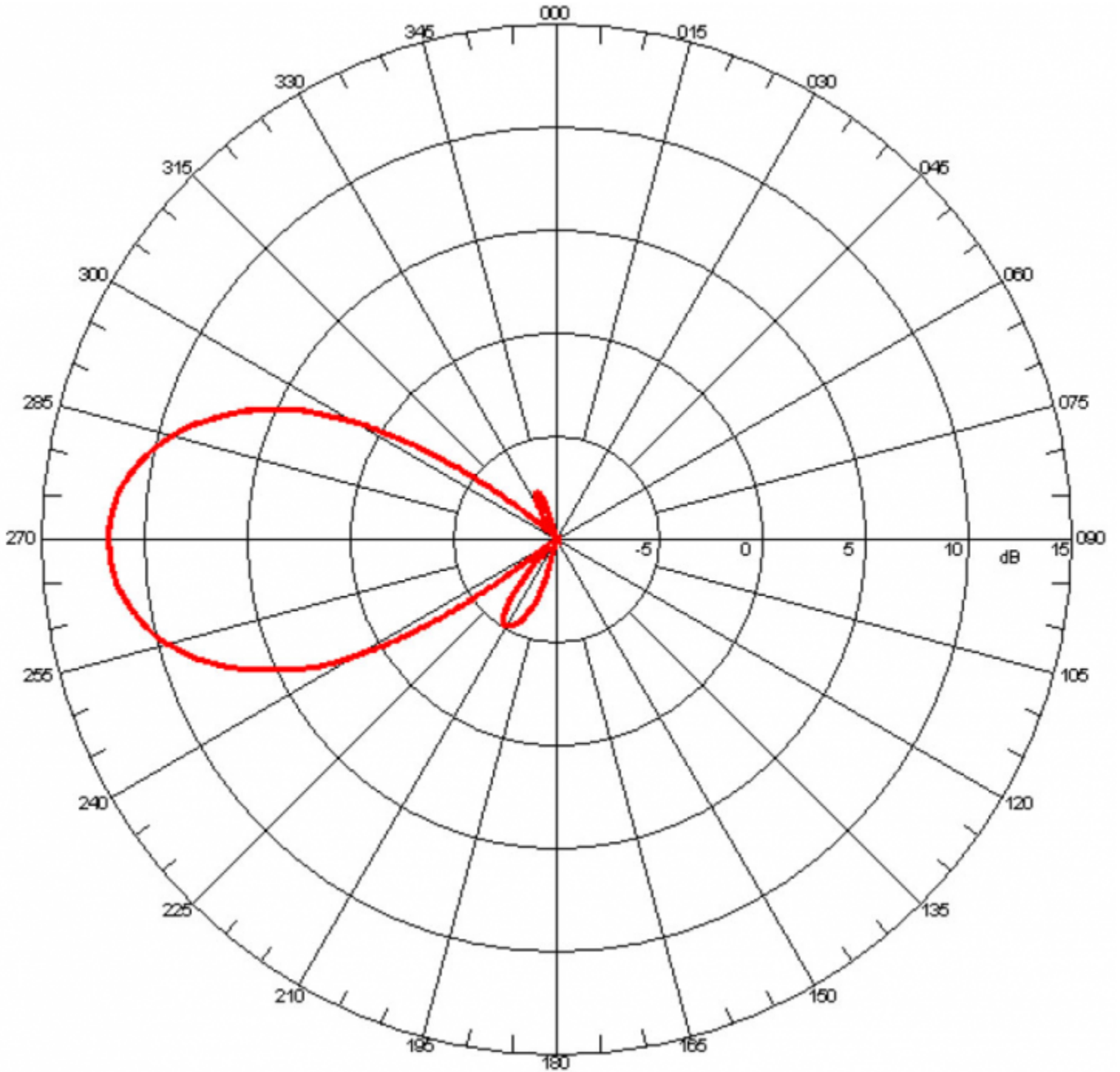

Elevation Pattern

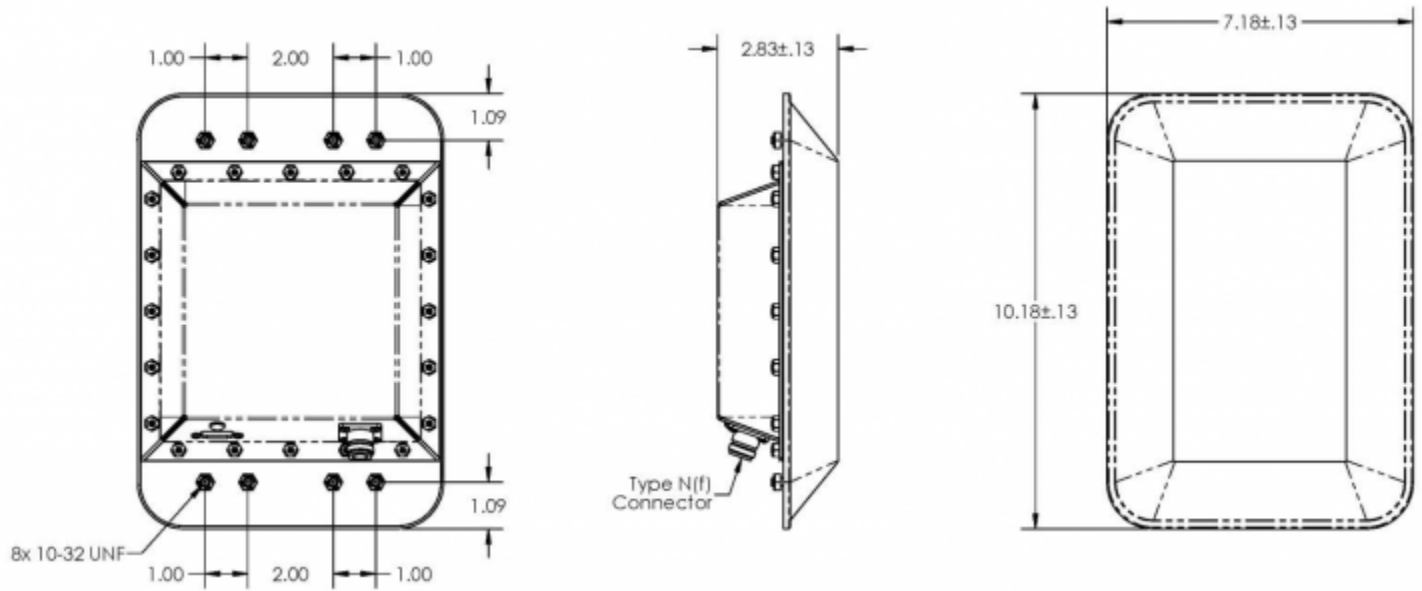

Engineering Drawing

Dimensions are in inches

THE WORLD LEADER IN HIGH PERFORMANCE WRAPAROUND™ ANTENNAS.



BROADBAND BUTTON ANTENNA P/N BNI-13110

Model BN1-13110 is designed to operate at telemetry frequencies within L-, S-, and C-Band. Over the frequency ranges 1.4-2.7 GHz and 4.0-5.5 GHz, it provides both low VSWR and excellent omnidirectional pattern coverage.

Haigh-Farr Button antennas are designed for applications where size and weight are critical. They utilize well-proven materials and methods of construction, providing a solid package and requiring only one "D" hole installed in the vehicle for mounting. Superb protection is obtained through the use of a high-impact, high-temperature radome, with excellent properties in environments containing moisture and contaminants.

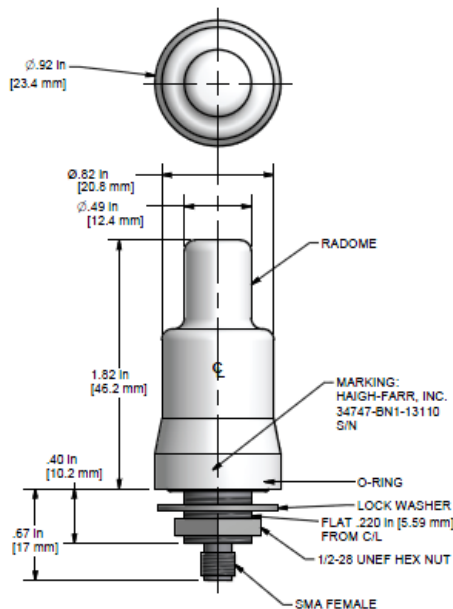

ELECTRICAL:

Frequency Bands:	1.4-2.7 GHz and 4.0-5.5 GHz
Power:	>30W Average
VSWR:	<1.6:1 typical, 2:1 max over operating bands
Input Impedance:	50 Ohms nominal
Polarization:	Linear, vertical
Radiation Pattern:	Omni-directional

MECHANICAL:

Connector:	SMA Female Standard (TNC Optional)
Dimensions:	See above drawing
Weight:	1.9 oz (55 gm)
Finish:	All exposed metallic surfaces are passivated stainless steel
Environmental:	Typical for supersonic airborne applications
Mounting:	Through "D" hole in vehicle and secured using lock washer and nut

DESIGN CAPABILITY

Haigh-Farr has an over 40 year history of designing and producing exceptionally rugged, high-performance antennas. If you don't find an antenna meeting your requirements in our standard list of products, Haigh-Farr has the experience and modeling capability to customize a solution. Adaptations of existing designs can be done with very short lead times. Contact Haigh-Farr for a review of your antenna requirements.

Haigh-Farr, Inc. 43 Harvey Road, Bedford NH 03110
Tel: 603-644-6170 Fax: 603-644-6190

E-mail: sales@haigh-farr.com Web Site: www.haigh-farr.com

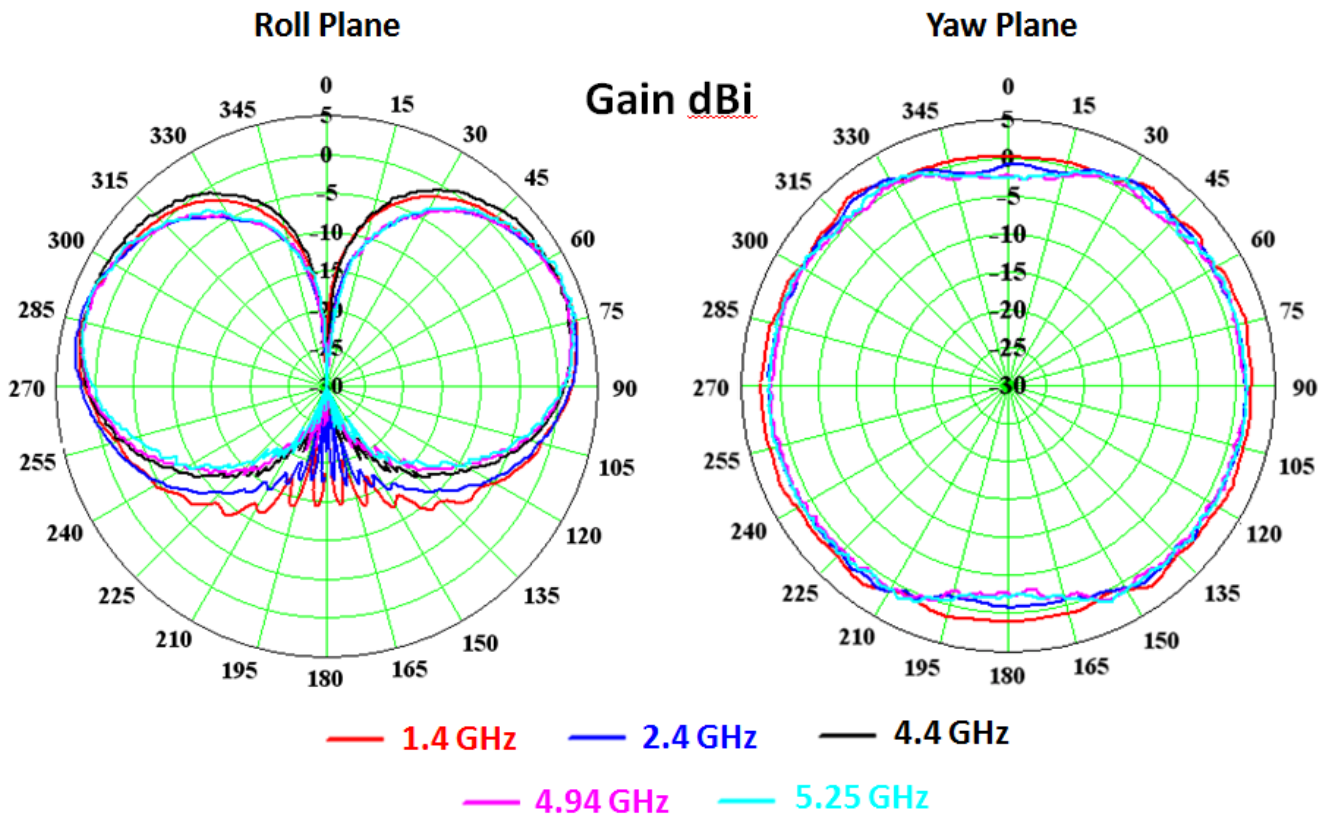
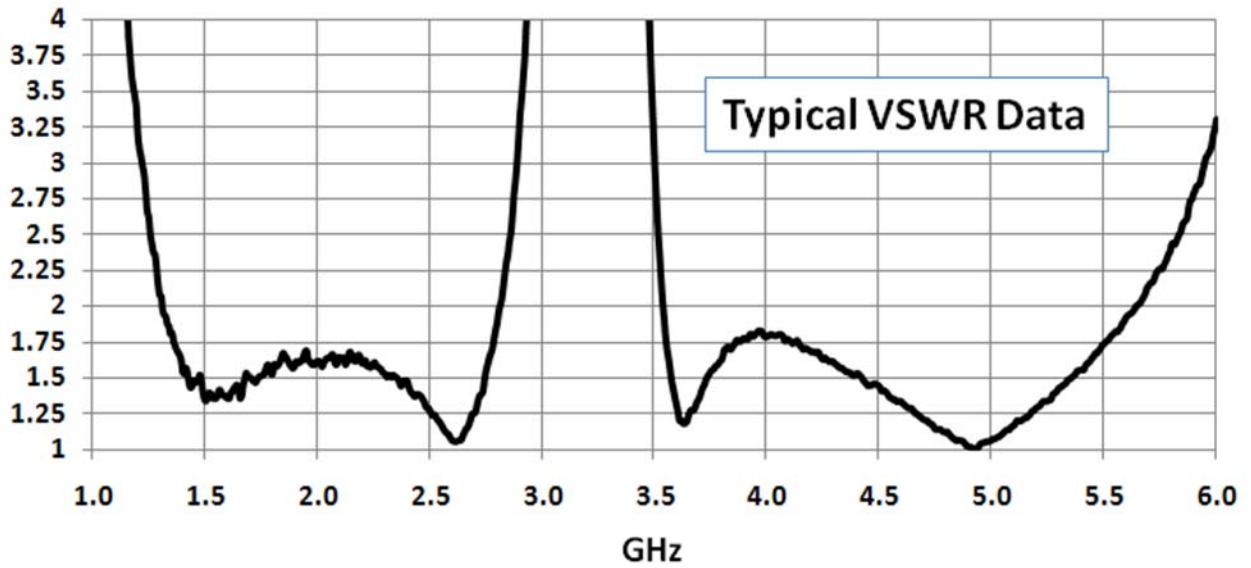

Note: Measured on a 40" diameter, 6' long cylindrical ground plane. Fins and other protrusions on the vehicle will perturb the radiation pattern. The extent of any perturbations cannot be fully determined until radiation patterns are either calculated or measured on a model of the vehicle. Haigh-Farr offers engineering services, which include the calculation of radiation patterns on a specific vehicle.