

EXHIBIT #1 as part of  
FCC FORM 442 – APPLICATION FOR NEW RADIO STATION UNDER PART 5 OF FCC RULES –  
EXPERIMENTAL RADIO SERVICE (OTHER THAN BROADCAST)

submitted by ARTEMIS, INC. File # 0221-EX-CN-2017

This exhibit addresses: FORM 442 QUESTION 7: EXPERIMENTATION DESCRIPTION

The proposed radiating device is a synthetic aperture radar (SAR) system being developed by ARTEMIS, INC. For the remainder of this document, it will be referred to as “SlimSAR,” which is an ARTEMIS, INC. internal designation for this project. SlimSAR is an imaging radar designed to be mounted on a small manned aircraft or unmanned aircraft system (UAS) and flown over an area of interest. The radar system transmits a frequency modulated, continuous wave signal, and records any signals reflected by targets on the ground.

## Description of Equipment and Theory of Operation

SAR works in much the same way as traditional surveillance radar systems. A modulated pulse is transmitted, and echoes from targets in the field of view of the radar are recorded. In order to create high-resolution images of the observed area, signal processing techniques are used to coherently average consecutive radar pulses collected from a moving platform. Each of these radar pulses encounters a given target from a slightly different angle, and provides non-redundant information about the target being imaged. When properly processed, SAR images have a much finer resolution in the direction of platform travel than is provided by the antenna footprint alone. SAR images are useful for surveillance and reconnaissance as well as geological, oceanographic, and other scientific observations. Targets and features which may be difficult to detect at IR or optical wavelengths are often quite prominent in SAR images because the illumination source is in the radio frequencies. Man made structures and metal objects, for instance, stand out particularly well.

A SAR image may reveal different properties of the imaged scene depending on the frequency of the transmitted signal. Images created at an extremely high frequency (Ka-band, for instance) tend to closely resemble optical images because the scattering of the radar signals resembles the scattering of light. The SlimSAR is designed to operate at X-band and Ka-band to take advantage of the properties of these frequency bands.

The range resolution of a SAR system is inversely proportional to the bandwidth of the signal being transmitted. It is governed by the relation

$$\Delta r = \frac{c_0}{2B}$$

where  $\Delta r$  is the range resolution,  $c_0$  is the speed of light in free space, and  $B$  is the bandwidth of the transmitted signal. In order to form a high-resolution SAR image, therefore, it is necessary to transmit a relatively high-bandwidth signal. The proposed bandwidth of 2000 MHz for Ka-band gives SlimSAR a resolution of approximately 0.09 meters and the bandwidth of 650 MHz for X-band gives a resolution of approximately 0.28 meters. This allows targets, such as buildings and vehicles, to be identified, with many of their features resolved. (A detailed description of the SlimSAR transmitted waveform is found in Exhibit #3 – MODULATING SIGNAL DESCRIPTION).

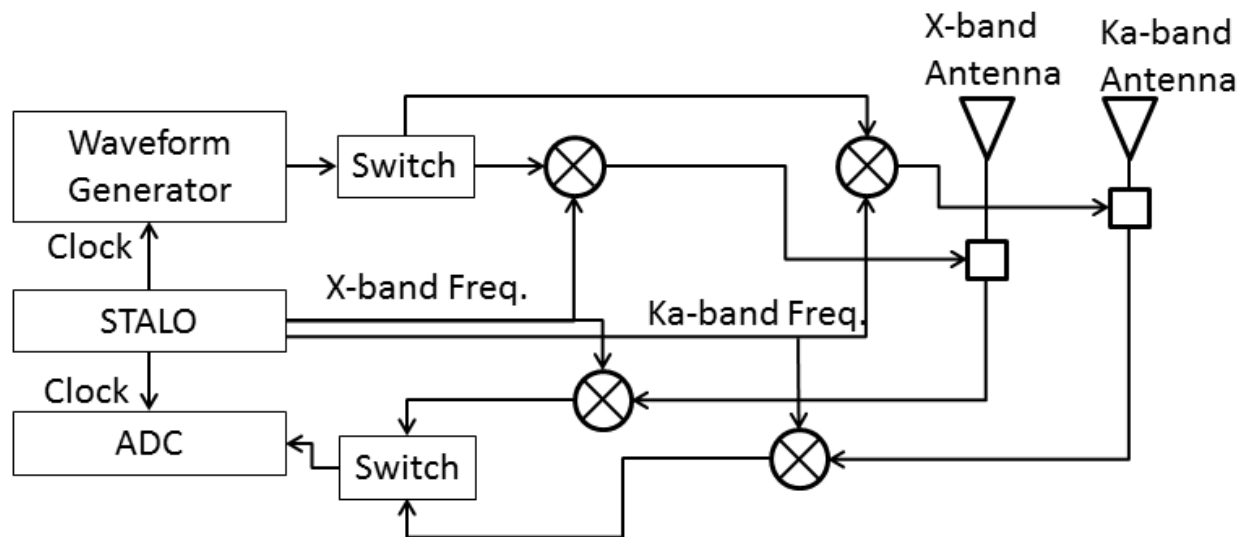

*Illustration 1: Block diagram showing the transmit signal generation path for SlimSAR.*

SAR systems can be classified as either pulsed or continuous wave. A pulsed radar transmits a short radar pulse, and then waits to receive echoes. A continuous wave radar transmits longer pulses with no break between them. SlimSAR is a linear frequency modulated (LFM) pulsed SAR system. SlimSAR is designed to transmit LFM pulsed signals at 70 W peak power at Ka-band, with an average power of 16.6 W, and 25 W peak power at X-band with 5.93 W average power.

A block diagram of the SlimSAR transmitter is shown in Illustration 1. The transmit signal is generated by a waveform generator. This signal is mixed with an LO corresponding to either Ka-band or X-band. The signal is transmitted through a directional antenna mounted so that it points at roughly a 45° angle to one side of the aircraft. (A detailed description of the antenna mounting and pattern is found in Exhibit #2 – DIRECTIONAL ANTENNA INFORMATION).

## Proposed Program of Research

The SlimSAR system has been developed and is ready for testing. Flight tests will be performed on an ARTEMIS Inc. owned, manned aircraft over remote locations near Spanish Fork, UT where there is limited human interaction. It is expected that weekly tests of a few hours duration will be adequate to gather necessary data. The data gathered from these tests will be used to verify proper operation of the SlimSAR hardware and develop signal processing algorithms which will accomplish the program objectives. These objectives include:

- processing of raw SlimSAR data into high-resolution images,
- developing signal processing algorithms which enhance the utility of the processed data.

Algorithm development will be ongoing during the period of flight testing, allowing developers to request SAR data containing certain test conditions. These conditions can be created during the next scheduled flight test and the data used immediately for rapid development of robust, fully-tested processing algorithms.

## **Contribution to the Advancement of Radar Technology**

SAR systems have been developed and built for decades, but supporting technologies such as digital processors and storage devices have only recently advanced to the point that small, lightweight, SAR systems are practical and cost-effective. SlimSAR's unique design puts it on the cutting edge of small SAR systems designed for operation on an unmanned aircraft system. UAS based surveillance and intelligence-gathering solutions are in high demand, and SlimSAR fills a need which has not yet been satisfactorily addressed. The system uses very little power, but is capable of generating high-quality SAR images which can be used for a number of applications. The data gathered during this program will be instrumental in advancing UAS-based SAR systems.