

EXHIBIT #1 as part of
FCC FORM 442 – APPLICATION FOR NEW RADIO STATION UNDER PART 5 OF FCC RULES
– EXPERIMENTAL RADIO SERVICE (OTHER THAN BROADCAST)

submitted by ARTEMIS, INC. File # 0046-EX-PL-2009

This exhibit addresses: FORM 442 QUESTION 7: EXPERIMENTATION DESCRIPTION

The proposed radiating device is a synthetic aperture radar (SAR) system being developed by ARTEMIS, INC. For the remainder of this document, it will be referred to as “SlimSAR,” which is an ARTEMIS, INC. internal designation for this project. SlimSAR is an imaging radar designed to be mounted on a small manned aircraft or unmanned aircraft system (UAS) and flown over an area of interest. The radar system transmits a frequency modulated, continuous wave signal, and records any signals reflected by targets on the ground.

Description of Equipment and Theory of Operation

SAR works in much the same way as traditional surveillance radar systems. A modulated pulse is transmitted, and echoes from targets in the field of view of the radar are recorded. In order to create high-resolution images of the observed area, signal processing techniques are used to coherently average consecutive radar pulses collected from a moving platform. Each of these radar pulses encounters a given target from a slightly different angle, and provides non-redundant information about the target being imaged. When properly processed, SAR images have a much finer resolution in the direction of platform travel than is provided by the antenna footprint alone. SAR images are useful for surveillance and reconnaissance as well as geological, oceanographic, and other scientific observations. Targets and features which may be difficult to detect at IR or optical wavelengths are often quite prominent in SAR images because the illumination source is in the radio frequencies. Man made structures and metal objects, for instance, stand out particularly well.

A SAR image may reveal different properties of the imaged scene depending on the frequency of the transmitted signal. Images created at an extremely high frequency (Ku-band, for instance) tend to closely resemble optical images. The longer wavelength of an L-band signal allows it to interact with physical objects differently. For example, tree leaves are generally small compared to the wavelength of an L-band signal and are nearly transparent in a SAR image created at these frequencies. L-band signals are also capable of penetrating up to a few meters in dry ground. These properties make an L-band SAR system ideal for imaging targets which are partially buried or obscured by trees. SlimSAR is built to operate in the L-band for precisely this reason.

The range resolution of a SAR system is inversely proportional to the bandwidth of the signal being transmitted. It is governed by the relation

$$\Delta r = \frac{c_0}{2B}$$

where Δr is the range resolution, c_0 is the speed of light in free space, and B is the bandwidth of the transmitted signal. In order to form a high-resolution SAR image, therefore, it is necessary to transmit a relatively high-bandwidth signal. The proposed bandwidth of 85 MHz gives SlimSAR a resolution of approximately 1.75 meters. This allows large targets such as buildings and vehicles to be distinguished, although fine details are not resolved. (A detailed description of the SlimSAR transmitted waveform is found in Exhibit #3 – MODULATING SIGNAL DESCRIPTION).

SlimSAR Transmitter Block Diagram

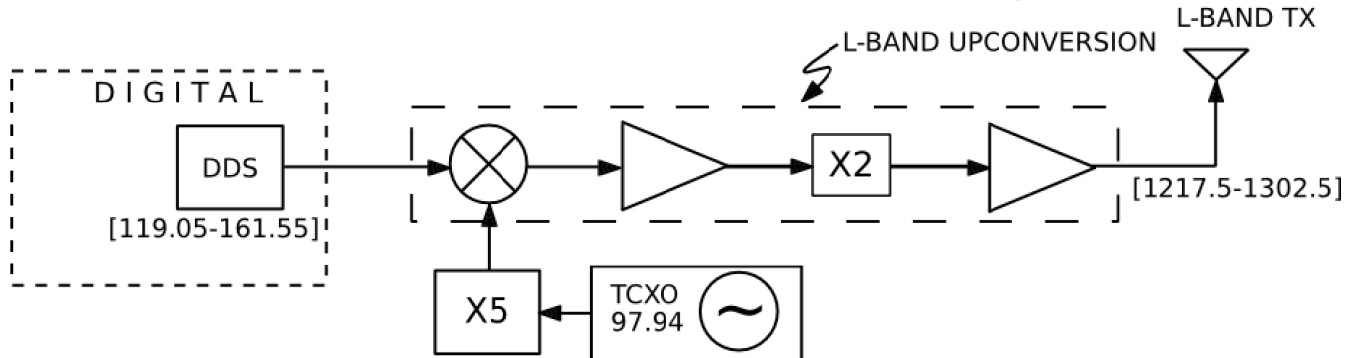

Illustration 1: Block diagram showing the transmit signal generation path for SlimSAR.

SAR systems can be classified as either pulsed or continuous wave. A pulsed radar transmits a short radar pulse, and then waits to receive echoes. A continuous wave radar transmits longer pulses with no break between them. SlimSAR is a continuous wave SAR system. Because it is constantly transmitting, SlimSAR is capable of maintaining a high SNR while operating at a much lower peak transmit power than comparable pulsed SAR systems. SlimSAR is designed to transmit a continuous wave signal of only 4 W peak power.

A block diagram of the SlimSAR transmitter is shown in Illustration 1. A 42.5 MHz linear frequency modulated (LFM) signal is generated by a direct digital synthesizer (DDS). This signal is mixed with a 489.7 MHz LO, then doubled to produce an 85 MHz wide transmit signal which extends from 1217.5 MHz to 1302.5 MHz. The signal is transmitted through a directional antenna mounted so that it points at a 45° angle to one side of the aircraft. (A detailed description of the antenna mounting and pattern is found in Exhibit #2 – DIRECTIONAL ANTENNA INFORMATION).

Proposed Program of Research

The SlimSAR system is currently under development and will be ready for testing beginning in the summer of 2009. Flight tests will be performed on an ARTEMIS INC. owned, manned aircraft. It is expected that weekly or fortnightly tests of a few hours duration will be adequate to gather necessary data. The data gathered from these tests will be used to verify proper operation of the SlimSAR hardware and develop signal processing algorithms which will accomplish the program objectives. These objectives include:

- processing of raw SlimSAR data into high-resolution images,
- verifying foliage and ground penetrating capabilities of SlimSAR,
- developing signal processing algorithms which enhance the utility of the processed data.

Algorithm development will be ongoing during the period of flight testing, allowing developers to request SAR data containing certain test conditions. These conditions can be created during the next scheduled flight test and the data used immediately for rapid development of robust, fully-tested processing algorithms.

Contribution to the Advancement of Radar Technology

SAR systems have been developed and built for decades, but supporting technologies such as digital processors and storage devices have only recently advanced to the point that small, lightweight, SAR systems are practical and cost-effective. SlimSAR's unique design puts it on the cutting edge of small SAR systems designed for operation on an unmanned aircraft system. UAS based surveillance and intelligence-gathering solutions are in high demand, and SlimSAR fills a need which has not yet been satisfactorily addressed. The system uses very little power (4 W peak transmit power), but is capable of generating high-quality SAR images which can be used for a number of applications. Of particular interest is the system's capability to detect objects which are partially buried or obscured by trees. The data gathered during this program will be instrumental in advancing UAS-based SAR systems.