

## Exhibit I.

AlliedSignal is currently continuing its activities in a research and development program aimed at producing Traffic Alert and Collision Avoidance Systems, TCAS I and TCAS II Airborne Equipment. The basic function of TCAS is to determine the presence of other aircraft in the vicinity of the TCAS equipped aircraft and to annunciate their locations to the pilot. These systems will interrogate airborne ATCRBS and Mode S transponders using a frequency of 1030 Mhz and receive replies using the frequency of 1090 MHz. The TCAS I equipment will be designed to meet the requirements of FAA TSO-C118 which references RTCA/DO-197 as the Minimum Operational Performance Standard and the TCAS II equipment will be designed to meet the requirements of FAA TSO-C119 which references RTCA/DO-185 as the Minimum Operational Performance Standard.

### Part (b) - Specific Objectives.

As part of the program described in Part (a) above, we would like to perform tests in which the TCAS equipment will interrogate aircraft from a fixed ground-based antenna located on the roof of our facilities in Olathe, Kansas. These tests will allow us to expose our equipment to an actual airspace RF environment without having to fly it and all of the associated development test equipment in a test aircraft.

### Part (c) - Contribution of the Program.

This program will contribute to the expansion and utilization of the radio art in that it will provide new TCAS I and II Airborne Equipment for the aviation industry.

Exhibit II.

Excerpt from RTCA/DO-185, MINIMUM OPERATIONAL PERFORMANCE STANDARDS FOR TRAFFIC ALERT AND COLLISION AVOIDANCE SYSTEM (TCAS) AIRBORNE EQUIPMENT, VOLUME I pages 22-25. See attached.

### 2.2.3.2.1 Interrogation Spectrum

The spectrum of a TCAS Mode S or ATRBS Interrogation shall not exceed the following:

<u>Frequency Difference (MHz From Carrier)</u>	<u>Maximum Relative Power (dB Down From Peak)</u>
.GE. 4 and .LT. 61	6
.GE. 6 and .LT. 8	11
.GE. 8 and .LT. 10	15
.GE. 10 and .LT. 20	19
.GE. 20 and .LT. 30	31
.GE. 30 and .LT. 40	38
.GE. 40 and .LT. 50	43
.GE. 50 and .LT. 60	47
.GE. 60 and .LT. 90	50
.GE. 90	60

### 2.2.3.2.2 Unwanted Output Power

When the TCAS interrogator is in the inactive state, the RF power at 1030 +3 MHz at the terminals of the antenna shall not exceed -70 dBm. The inactive state is defined to include the entire period between ATRBS and/or Mode S interrogations less 10  $\mu$ s transition periods, if necessary, preceding and following the extremes of the interrogation transmission.

*Note: This power restriction is necessary to ensure that TCAS does not prevent the on-board Mode S transponder from meeting its sensitivity and interference rejection requirements. It assumes that the isolation between the TCAS antenna and the Transponder antenna exceeds 20 dB.*

### 2.2.3.3 Interrogation Repetition Interval

The nominal surveillance update interval shall be one second for all ATRBS and Mode S aircraft under surveillance.

The nominal interval between TCAS Broadcast Interrogation Transmissions (subparagraph 2.2.8.2.4) shall be 10 seconds.

#### 2.2.3.3.1 Interrogation Interval Jitter

The transmission time of each ATRBS interrogation sequence and each TCAS Broadcast Interrogation shall be intentionally jittered about nominal update intervals of one second and 10 seconds respectively. The jitter shall vary randomly and be sufficient to prevent synchronous interference with other ground-based and airborne interrogators. The maximum value of the jitter shall not exceed 10 percent of the nominal update interval.

*Note: It is not necessary to intentionally jitter Mode S surveillance interrogations because of the inherently random nature of the Mode S interrogation scheduling process (subparagraph 2.2.8.9).*

#### 2.2.3.3.2 Interrogation Rate

The total interrogation rate shall be controlled by the interference limiting procedures of subparagraph 2.2.6.2.

*Note: The number of interrogations transmitted in any one-second interval depends on the number of Mode S transponders within detection range.*

2.2.3.4 Transmitter Delay Differences

The total difference in mean transmitter delay between the top and bottom antenna channels (including the transponder-to-antenna transmission lines) shall not exceed 0.05  $\mu$ s.

2.2.4 TCAS Transmitter Pulse Characteristics

2.2.4.1 TCAS to ATRBS Transmissions

ATCRBS interrogations from omni-directional TCAS equipment shall employ the "Mode-C-Only All-Call" format which consists of three pulses  $P_1$ ,  $P_3$  and  $P_4$ . This shall normally be preceded by an ATRBS "whisper-shout" suppression pulse designated  $S_1$ , (see subparagraph 2.2.8.1.2). These formats are illustrated in Figure 2-1. The pulses shall have shapes and spacings as tabulated below.

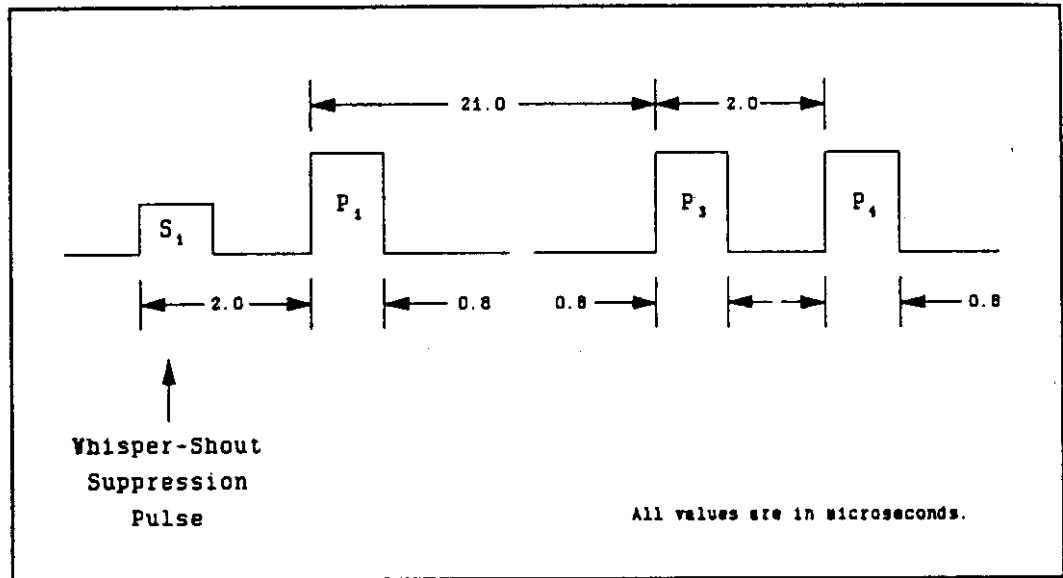

**FIGURE 2-1 TCAS MODE-C-ONLY ALL-CALL INTERROGATION SEQUENCE**

The rise and decay time may be less than shown in the table, providing the side-band radiation does not exceed the spectral limits tabulated in subparagraph 2.2.3.2.1. The amplitude of  $P_3$  shall be within 0.5 dB of the amplitude of  $P_1$ , and the amplitude of  $P_4$  shall be within 0.5 dB of the amplitude of  $P_3$ . The amplitude of  $S_1$  is specified in subparagraph 2.2.8.1.2.

**TCAS ATCRBS PULSE SHAPES**  
(All values in  $\mu\text{s}$ )

Pulse Designator	Pulse Duration	Duration Tolerance	Rise Time		Decay Time	
			Min.	Max.	Min.	Max.
$S_1, P_1, P_3, P_4$	0.8	+0.05	0.05	0.1	0.05	0.2

The pulse spacing tolerances shall be as follows:

$P_1$  to  $P_2$ : 2 +0.10  $\mu\text{s}$ ;  
 $P_1$  to  $P_3$ : 21 +0.10  $\mu\text{s}$ ;  
 $P_3$  to  $P_4$ : 2 +0.04  $\mu\text{s}$ .

**Note:** The tolerance values on these pulse widths, spacings and amplitudes are smaller than the signal-in-space tolerance values defined in Ref. B in order to provide margin for waveform distortion due to multipath.

## 2.2.4.2

TCAS to Mode S Transmissions

Mode S transmissions shall consist of  $P_1$ ,  $P_2$  and  $P_6$  pulses as shown in Figure 2-2.

**TCAS MODE S PULSE SHAPES**  
(All values in  $\mu\text{s}$ ).

Pulse Designator	Pulse Duration	Duration Tolerance	Rise Time		Decay Time	
			Min.	Max.	Min.	Max.
$P_1, P_2$	0.8	+0.05	0.05	0.1	0.05	0.2
$P_6$ (Short)	16.25	+0.125	0.05	0.1	0.05	0.2
$P_6$ (Long)	30.25	+0.125	0.05	0.1	0.05	0.2

The short (16.25- $\mu\text{s}$ ) and long (30.25- $\mu\text{s}$ )  $P_6$  pulses shall have internal modulation consisting of possible 180-degree phase reversals of the carrier at designated times. The first phase reversal in the  $P_6$  pulse is the sync phase reversal and is always present. The presence or absence of a subsequent phase reversal indicates a one or zero in the transmitted code respectively.

**Note:** The sync phase reversal is the timing reference provided to identify chip positions to Mode S Interrogation decoders.

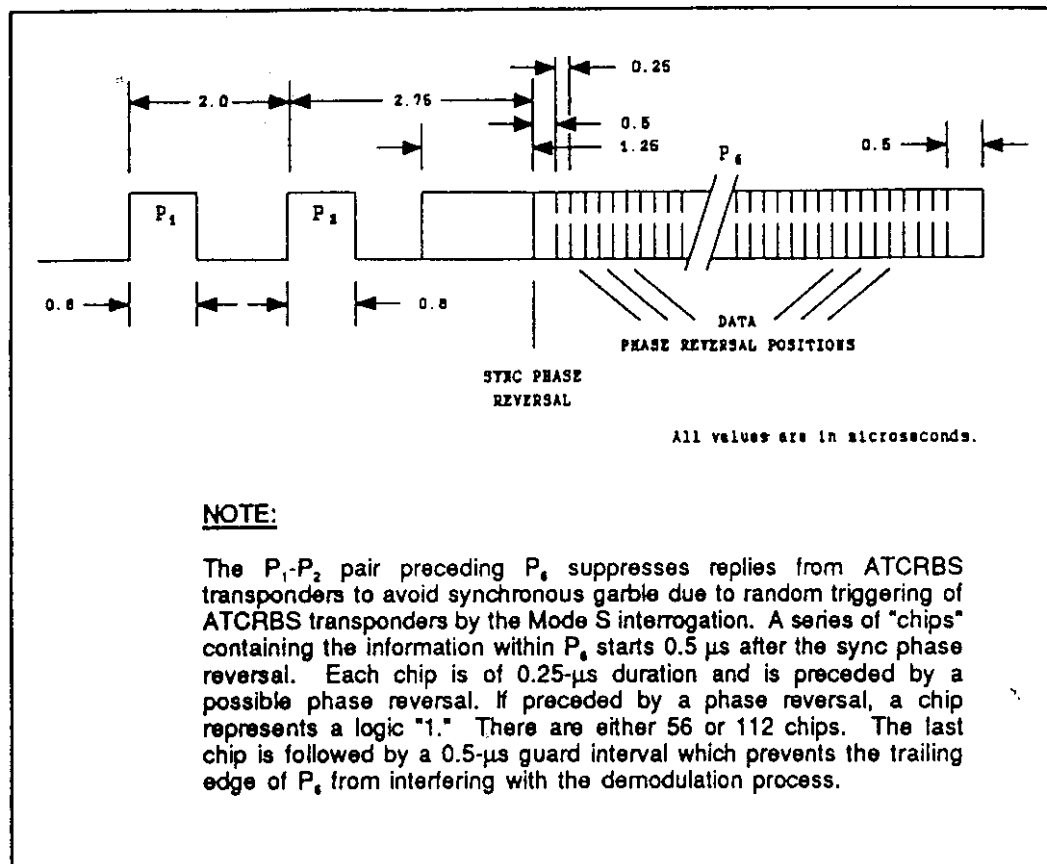

**FIGURE 2-2 MODE S TRANSMISSION**

The duration of a phase reversal in  $P_3$  shall be less than 0.08  $\mu\text{s}$  as measured between the 10-degree and 170-degree points of the phase transition. The interval between the 80-percent points of the amplitude transient associated with the phase reversal shall be less than 0.08  $\mu\text{s}$ .

The tolerance on the 0- and 180-degree phase relationships in  $P_3$  shall be  $\pm 5$  degrees.

The 90-degree point of each data phase reversal in  $P_3$  shall occur only at a time  $(N \times 0.25) + 0.02 \mu\text{s}$  ( $N \geq 2$ ) after the 90-degree point of the sync phase reversal.

*Note:* 56 or 112 data phase reversals can occur in the 16.25- and 30.25- $\mu\text{s}$   $P_3$  pulses respectively. This results in a four Mbit/s data rate within the  $P_3$  pulses.

The spacing from  $P_1$  to  $P_2$  shall be  $2 \pm 0.04 \mu\text{s}$  between leading edges. The spacing from the leading edge of  $P_2$  to the 90-degree point of the sync phase reversal of  $P_3$  shall be  $2.75 \pm 0.04 \mu\text{s}$ . The leading edge of  $P_3$  shall occur  $1.25 \pm 0.04 \mu\text{s}$  before the sync phase reversal.

The radiated amplitudes of  $P_2$  and the initial first  $\mu\text{s}$  of  $P_3$  shall be greater than the radiated amplitude of  $P_1$  minus 0.25 dB. The maximum envelope amplitude variation between successive phase modulation chips in  $P_3$  shall be less than 0.25 dB.