

TEST REPORT

Applicant Name: FCC: VTech Telecommunications Ltd
IC: VTECH TELECOMMUNICATIONS LIMITED
Address: FCC: 23/F Tai Ping Ind Center Block 1 57 Ting Kok Rd Tai Po
NT, Hong Kong
IC: BL.1 23/F Tai Ping Industr Ctr. 57 Ting Kok Road Tai Po,
NT Hongkong
Report Number: SZ1240103-00576E-RFB
FCC ID: EW780-H2B9-44
IC: 1135B-80H2B944

Test Standard (s)

FCC PART 15D; RSS-GEN ISSUE 5, FEBRUARY 2021 AMENDMENT 2; RSS-213, ISSUE 3,
MARCH 2015

Sample Description

Product Type: SIP cordless hotel phone
Model No.: PMX-S5410
Multiple Model(s) No.: PMX-S5410 HC, PMX-S5410 HC-S, PMX-S5420, PMX-S5420
HC, PMX-S5420 HC-S
Trade Mark: vtech
Date Received: 2024/01/04
Issue Date: 2024/04/18

Test Result:	Pass▲
--------------	-------

▲ In the configuration tested, the EUT complied with the standards above.

Prepared and Checked By:

Andy Yu

Andy Yu
RF Engineer

Approved By:

Nancy Wang

Nancy Wang
RF Supervisor

Note: The information marked # is provided by the applicant, the laboratory is not responsible for its authenticity and this information can affect the validity of the result in the test report. Customer model name, addresses, names, trademarks etc. are included.

This report cannot be reproduced except in full, without prior written approval of the Company. Unless otherwise stated the results shown in this test report refer only to the sample(s) tested. This report is valid only with a valid digital signature. The digital signature may be available only under the Adobe software above version 7.0.

This report must not be used by the customer to claim product certification, approval, or endorsement by NVLAP or any agency of the U.S. Government.

This report may contain data that are not covered by the NVLAP accreditation and are marked with an asterisk "▼".

Bay Area Compliance Laboratories Corp. (Shenzhen)

5F(B-West), 6F, 7F, the 3rd Phase of Wan Li Industrial Building D, Shihua Rd, FuTian Free Trade Zone, Shenzhen, China

Tel: +86-755-33320018 Fax: +86-755-33320008 www.baclcorp.com.cn

TABLE OF CONTENTS

DOCUMENT REVISION HISTORY	4
GENERAL INFORMATION.....	5
PRODUCT DESCRIPTION FOR EQUIPMENT UNDER TEST (EUT).....	5
OBJECTIVE	5
TEST METHODOLOGY	5
MEASUREMENT UNCERTAINTY.....	6
TEST FACILITY	6
SYSTEM TEST CONFIGURATION.....	7
DESCRIPTION OF TEST CONFIGURATION	7
EQUIPMENT MODIFICATIONS	7
SUPPORT EQUIPMENT LIST AND DETAILS	7
EXTERNAL I/O CABLE.....	7
BLOCK DIAGRAM OF TEST SETUP	7
SUMMARY OF TEST RESULTS	8
TEST EQUIPMENT LIST	9
FCC §1.1307 & §2.1093 - RF EXPOSURE.....	11
APPLICABLE STANDARD	11
TEST RESULT	11
RSS-102 – RF EXPOSURE.....	12
APPLICABLE STANDARD	12
§ 15.317, § 15.203 & RSS-GEN §6.8 ANTENNA REQUIREMENT.....	13
APPLICABLE STANDARD	13
ANTENNA CONNECTOR CONSTRUCTION	13
§ 15.323 (A) & RSS-213 §5.5 EMISSION BANDWIDTH.....	14
APPLICABLE STANDARD	14
TEST PROCEDURE	14
TEST DATA	15
§ 15.319 (C) & RSS-213 §5.6 PEAK TRANSMIT POWER	19
APPLICABLE STANDARD	19
TEST PROCEDURE	19
TEST DATA	20
§ 15.319 (D) & RSS-213 §5.7 POWER SPECTRAL DENSITY.....	22
APPLICABLE STANDARD	22
TEST PROCEDURE	22
TEST DATA	23

§15.319 (G), § 15.323 (D) & RSS-213 §5.8 EMISSION INSIDE AND OUTSIDE THE SUB-BAND.....27

 APPLICABLE STANDARD27

 TEST PROCEDURE28

 SPURIOUS RADIATED EMISSION SET UP:.....29

 EMI TEST RECEIVER & SPECTRUM ANALYZER SETUP30

 TEST PROCEDURE30

 FACTOR & OVER LIMIT/MARGIN CALCULATION31

 TEST DATA31

§ 15.323 (F) & RSS-213 §5.3 FREQUENCY STABILITY54

 APPLICABLE STANDARD54

 TEST PROCEDURE54

 TEST DATA55

§ 15.323 (C)(E)§ 15.319 (F) & RSS-213 §5.1&§5.2 SPECIFIC REQUIREMENTS FOR UPCS DEVICE56

 APPLICABLE STANDARD56

 TEST PROCEDURE56

 TEST DATA56

 1) AUTOMATIC DISCONTINUATION OF TRANSMISSION.....57

 2) MONITORING TIME57

 3) LOWER MONITORING THRESHOLD.....57

 4) MAXIMUM TRANSMIT PERIOD57

 5) SYSTEM ACKNOWLEDGEMENT58

 6) LEAST INTERFERED CHANNEL (LIC)58

 7) RANDOM WAITING59

 8) MONITORING BANDWIDTH AND REACTION TIME59

 9) MONITORING ANTENNA.....59

 10) MONITORING THRESHOLD RELAXATION59

 11) DUPLEX CONNECTIONS.....60

 12) ALTERNATIVE MONITORING INTERVAL60

 13) FAIR ACCESS60

 14) FRAME REPETITION STABILITY FRAME PERIOD AND JITTER60

EUT PHOTOGRAPHS61

TEST SETUP PHOTOGRAPHS62

DOCUMENT REVISION HISTORY

Revision Number	Report Number	Description of Revision	Date of Revision
0	SZ1240103-00576E-RFB	Original Report	2024/04/18

GENERAL INFORMATION

Product Description for Equipment under Test (EUT)

HVIN	35-400188HS
FVIN	PMX_1.02.02-33
Product	SIP cordless hotel phone
Tested Model	PMX-S5410
Multiple Model(s)	PMX-S5410 HC, PMX-S5410 HC-S, PMX-S5420, PMX-S5420 HC, PMX-S5420 HC-S
Frequency Range	1921.536-1928.448 MHz
Maximum conducted peak output power	19.94dBm
Modulation Technique	GFSK
Antenna Specification [#]	0dBi (It is provided by the applicant)
Voltage Range	DC 3.7V from battery
Sample serial number	2G4S-12 for Radiated Emissions Test 2G4S-8 for RF Conducted Test (Assigned by BACL, Shenzhen)
Sample/EUT Status	Good condition
Adapter Information	N/A
Note: The Multiple models are electrically identical with the test model except for model name, base and charger. Please refer to the declaration letter [#] for more detail, which was provided by manufacturer.	

Objective

The tests were performed in order to determine the compliance of the EUT with FCC Part 15-Subpart D, section 15.317, 15.319 and 15.323 rules. The EMI measurements were performed according to the measurement procedure described in ANSI C63.17 – 2013 and RSS-213 Issue 3, 2GHz License-Exempt Personal Communications Service Devices (PCS) OF THE Canadian Department of Industry rules and RSS-GEN ISSUE 5, FEBRUARY 2021 AMENDMENT 2 of the Innovation, Science and Economic Development Canada rules.

Test Methodology

All measurements contained in this report were conducted with ANSI C63.17 - 2013, American National Standard Methods of Measurement of the Electromagnetic and Operational Compatibility of Unlicensed Personal Communications Services (UPCS) Devices.

All emissions measurement was performed at Bay Area Compliance Laboratories Corp. (Shenzhen). The radiated testing was performed at an antenna-to-EUT distance of 3 meters.

Each test item follows test standards and with no deviation.

Measurement Uncertainty

Parameter	Uncertainty	
Occupied Channel Bandwidth	±5%	
RF Frequency	213.55 Hz(k=2, 95% level of confidence)	
RF output power, conducted	0.72 dB(k=2, 95% level of confidence)	
Unwanted Emission, conducted	1.75 dB(k=2, 95% level of confidence)	
Radiated Emissions	9kHz - 30MHz	3.30dB(k=2, 95% level of confidence)
	30MHz~200MHz (Horizontal)	4.48dB(k=2, 95% level of confidence)
	30MHz~200MHz (Vertical)	4.55dB(k=2, 95% level of confidence)
	200MHz~1000MHz (Horizontal)	4.85dB(k=2, 95% level of confidence)
	200MHz~1000MHz (Vertical)	5.05dB(k=2, 95% level of confidence)
	1GHz - 6GHz	5.35dB(k=2, 95% level of confidence)
6GHz - 18GHz	5.44dB(k=2, 95% level of confidence)	
Temperature	±1°C	
Humidity	±1%	
Supply voltages	±0.4%	

Note: The extended uncertainty given in this report is obtained by combining the standard uncertainty times the coverage factor K with the 95% confidence interval. Otherwise required by the applicant or Product Regulations, Decision Rule in this report did not consider the uncertainty.

Test Facility

The Test site used by Bay Area Compliance Laboratories Corp. (Shenzhen) to collect test data is located on the 5F(B-West) , 6F, 7F, the 3rd Phase of Wan Li Industrial Building D, Shihua Rd, FuTian Free Trade Zone, Shenzhen, China.

The lab has been recognized as the FCC accredited lab under the KDB 974614 D01 and is listed in the FCC Public Access Link (PAL) database, FCC Registration No. : 715558, the FCC Designation No. : CN5045.

The lab has been recognized by Innovation, Science and Economic Development Canada to test to Canadian radio equipment requirements, the CAB identifier: CN0023.

SYSTEM TEST CONFIGURATION

Description of Test Configuration

The system was configured to testing mode which is provided by the manufacturer.

Equipment Modifications

No modification was made to the EUT tested.

Support Equipment List and Details

Manufacturer	Description	Model	Serial Number
Rohde & Schwarz	Digital Radio Communication Tester	CMD60	830553/018

External I/O Cable

Cable Description	Length (m)	From Port	To
/	/	/	/

Block Diagram of Test Setup

For Radiated Emission:

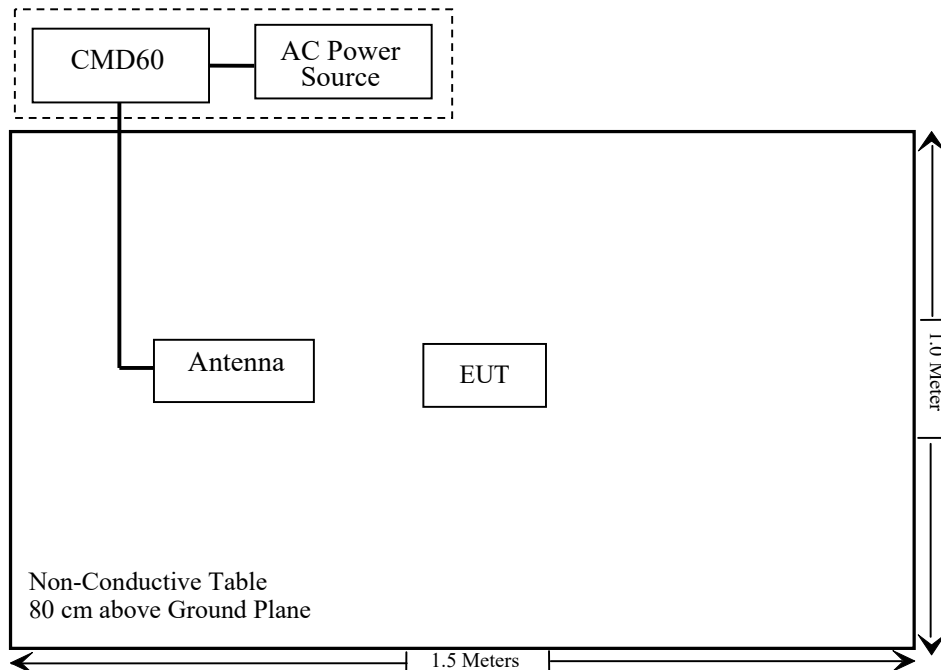

SUMMARY OF TEST RESULTS

FCC Rules	ISED Rules	Description of Test	Result
§ 1.1307 & 2.1093	RSS-102	RF EXPOSURE	Compliant
§ 15.317, § 15.203	RSS-Gen §6.8	Antenna Requirement	Compliant
§ 15.315, § 15.207	RSS-213 §5.4	Conducted Emission	Not Applicable
§ 15.323 (a)	RSS-213 §5.5	Emission Bandwidth	Compliant
§ 15.319 (c)	RSS-213 §5.6	Peak Transmit Power	Compliant
§ 15.319 (d)	RSS-213 §5.7	Power Spectral Density	Compliant
§ 15.323 (d)	RSS-213 §5.8	Emission Inside and Outside the sub-band	Compliant
§15.205, §15.209, § 15.319 (g)	RSS-213 §5.8	Radiated Emission	Compliant
§ 15.323 (f)	RSS-213 §5.3	Frequency Stability	Compliant
§ 15.323 (c)(e) § 15.319 (f)	RSS-213 §5.1&§5.2	Specific Requirements for UPCS	Compliant

Not Applicable: the DECT function cannot use when in charging.

TEST EQUIPMENT LIST

Manufacturer	Description	Model	Serial Number	Calibration Date	Calibration Due Date
Radiated Emission Test					
R&S	EMI Test Receiver	ESR3	102455	2024/01/16	2025/01/15
Sonoma instrument	Pre-amplifier	310 N	186238	2023/06/08	2024/06/07
Sunol Sciences	Broadband Antenna	JB1	A040904-1	2023/07/20	2024/07/19
ETS	Passive Loop Antenna	6512	29604	2023/07/07	2024/07/06
Unknown	Cable	Chamber Cable 1	F-03-EM236	2023/08/03	2024/08/02
Unknown	Cable	Chamber Cable 4	EC-007	2023/08/03	2024/08/02
Audix	EMI Test software	E3	19821b(V9)	NCR	NCR
Rohde & Schwarz	Spectrum Analyzer	FSV40	101605	2023/04/18	2024/04/17
COM-POWER	Pre-amplifier	PA-122	181919	2023/06/29	2024/06/28
Schwarzbeck	Horn Antenna	BBHA9120D(1201)	1143	2023/07/26	2024/07/25
Unknown	RF Cable	KMSE	0735	2023/10/08	2024/10/07
Unknown	RF Cable	UFA147	219661	2023/10/08	2024/10/07
Unknown	RF Cable	XH750A-N	J-10M	2023/10/08	2024/10/07
A.H.System	Pre-amplifier	PAM-1840VH	190	2023/08/03	2024/08/02
Electro-Mechanics Co	Horn Antenna	3116	2026	2023/09/18	2026/09/17
UTIFLEX	RF Cable	NO. 13	232308-001	2023/08/03	2024/08/02
Audix	EMI Test software	E3	191218(V9)	NCR	NCR
MICRO-TRONICS	2.8G Passband filter	HPM50111	F-03-EM217	2023/08/03	2024/08/02
Wainwright Germany	B1(DECT) Pass filter	1920-1980	F-03-EM233	2023/07/04	2024/07/03

Manufacturer	Description	Model	Serial Number	Calibration Date	Calibration Due Date
RF Conducted Test					
R&S	Spectrum analyzer	FSV40	101942	2023/12/18	2024/12/17
R&S	SPECTRUM ANALYZER	FSU26	200120	2024/01/08	2025/01/07
BACL	Temperature & Humidity Chamber	BTH-150-40	30145	2024/01/16	2025/01/15
Rohde & Schwarz	Digital Radio Communication Tester	CMD60	830553/018	2023/06/08	2024/06/07
Keysight	MXG Vector Signal Generator	N5182B	MY53051503	2024/01/08	2025/01/07
Fluke	Digital Multimeter	287	19000011	2023/06/08	2024/06/07
WEINSCHEL	3dB Attenuator	Unknown	F-03-EM220	2023/07/04	2024/07/03
WEINSCHEL	Power Splitter	1515	RH386	2023/07/04	2024/07/03
Unknown	RF Cable	65475	01670515	2023/07/04	2024/07/03
instek	DC Power Supply	GPS-3030DD	EM832096	NCR	NCR

* **Statement of Traceability:** Bay Area Compliance Laboratories Corp. (Shenzhen) attests that all calibrations have been performed in accordance to requirements that traceable to National Primary Standards and International System of Units (SI).

FCC §1.1307 & §2.1093 - RF EXPOSURE

Applicable Standard

FCC§1.1307 and §2.1093.

Test Result

Compliant, please refer to the SAR report: SZ1240103-00576E-SAA.

RSS-102 – RF EXPOSURE

Applicable Standard

According to RSS-102, systems operating under the provisions of this section shall be operated in a manner that ensures that the public is not exposed to radio frequency energy level in excess of the Commission's guideline.

Result: Compliant

Please refer to SAR Report Number: SZ1240103-00576E-SAB.

§ 15.317, § 15.203 & RSS-Gen §6.8 ANTENNA REQUIREMENT

Applicable Standard

According to FCC § 15.203, an intentional radiator shall be designed to ensure that no antenna other than that furnished by the responsible party shall be used with the device. The use of a permanently attached antenna or of an antenna that uses a unique coupling to the intentional radiator shall be considered sufficient to comply with the provisions of this Section. The manufacturer may design the unit so that a broken antenna can be replaced by the user, but the use of a standard antenna jack or electrical connector is prohibited.

The applicant for equipment certification shall provide a list of all antenna types that may be used with the transmitter, where applicable (i.e. for transmitters with detachable antenna), indicating the maximum permissible antenna gain (in dBi) and the required impedance for each antenna. The test report shall demonstrate the compliance of the transmitter with the limit for maximum equivalent isotropically radiated power (e.i.r.p.) specified in the applicable RSS, when the transmitter is equipped with any antenna type, selected from this list.

For expediting the testing, measurements may be performed using only the antenna with highest gain of each combination of transmitter and antenna type, with the transmitter output power set at the maximum level. However, the transmitter shall comply with the applicable requirements under all operational conditions and when in combination with any type of antenna from the list provided in the test report (and in the notice to be included in the user manual, provided below).

When measurements at the antenna port are used to determine the RF output power, the effective gain of the device’s antenna shall be stated, based on a measurement or on data from the antenna’s manufacturer.

The test report shall state the RF power, output power setting and spurious emission measurements with each antenna type that is used with the transmitter being tested.

For licence-exempt equipment with detachable antennas, the user manual shall also contain the following notice in a conspicuous location:

This radio transmitter [enter the device’s ISED certification number] has been approved by Innovation, Science and Economic Development Canada to operate with the antenna types listed below, with the maximum permissible gain indicated. Antenna types not included in this list that have a gain greater than the maximum gain indicated for any type listed are strictly prohibited for use with this device. Immediately following the above notice, the manufacturer shall provide a list of all antenna types which can be used with the transmitter, indicating the maximum permissible antenna gain (in dBi) and the required impedance for each antenna type.

Antenna Connector Construction

The EUT has an integral antenna arrangements which were permanently attached and both the gain[#] is 0dBi, fulfill the requirement of this section. Please refer to the EUT photos.

Type	Antenna Gain [#]	Impedance
Monopole	0dBi	50Ω

§ 15.323 (A) & RSS-213 §5.5 EMISSION BANDWIDTH

Applicable Standard

Operation shall be contained within the 1920–1930 MHz band. The emission bandwidth shall be less than 2.5 MHz and greater than 50 kHz.

The emission bandwidth is measured in accordance with ANSI C63.17 sub-clause 6.1.3 using the setup below:

Test Setup 1:

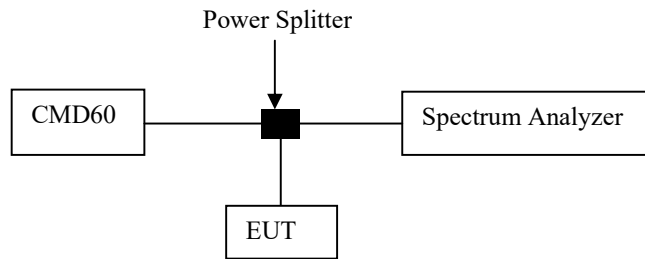

The width, in Hz, of the signal between two points, one below the carrier center frequency and one above the carrier center frequency, that is 26 dB down relative to the maximum level of the modulated carrier. It is based on the use of measurement instrumentation employing a peak detector function with an instrument resolution bandwidth approximately equal to 1% of the emission band-width of the device under measurement. [Extraction from 47 CFR 15, subpart D, 15.303 (C)].

Test Procedure

Using the manufacturer’s information on occupied bandwidth set the spectrum analyzer as follows:

Resolution bandwidth	1.0% of the emission bandwidth (as close as possible)
Video bandwidth	>3 times the resolution bandwidth
Number of sweeps	sufficient to stability the trace
Detection mode	peak detection with maximum hold

EBW:

The emission bandwidth (x dB) is defined as the frequency range between two points, one above and one below the carrier frequency, at which the spectral density of the emission is attenuated x dB below the maximum in-band spectral density of the modulated signal. Spectral density (power per unit bandwidth) is to be measured with a detector of resolution bandwidth in the range of 1% to 5% of the anticipated emission bandwidth, and a video bandwidth at least 3x the resolution bandwidth.

OBW:

- The transmitter shall be operated at its maximum carrier power measured under normal test conditions.
- The span of the analyzer shall be set to capture all products of the modulation process, including the emission skirts.
- The resolution bandwidth (RBW) shall be in the range of 1% to 5% of the occupied bandwidth (OBW) and video bandwidth (VBW) shall be approximately 3x RBW.

Test Data

Environmental Conditions

Temperature:	26.5 °C
Relative Humidity:	49 %
ATM Pressure:	101 kPa

The testing was performed by Bruce Lin on 2024-03-25.

Test mode: Transmitting

Test Result: Compliant

Channel	Center Frequency (MHz)	99% Emission Bandwidth (MHz)	26 dB Emission Bandwidth (MHz)	Limit
Low	1921.536	1.221	1.409	50 kHz ~ 2.5 MHz
Middle	1924.992	1.203	1.471	50 kHz ~ 2.5 MHz
High	1928.448	1.230	1.404	50 kHz ~ 2.5 MHz

99% Emission Bandwidth

Low Channel

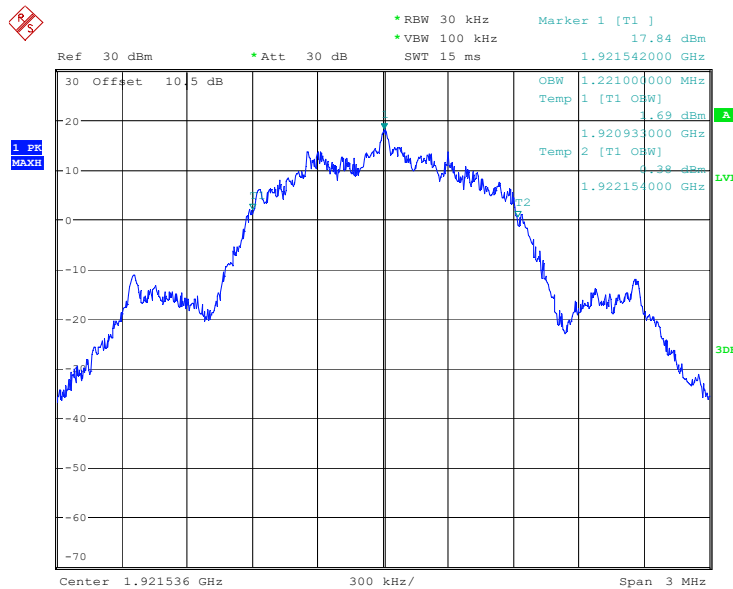

ProjectNo.:SZ1240103-00576E-PP Tester:Bruce Lin
 Date: 25.MAR.2024 21:59:37

Middle Channel

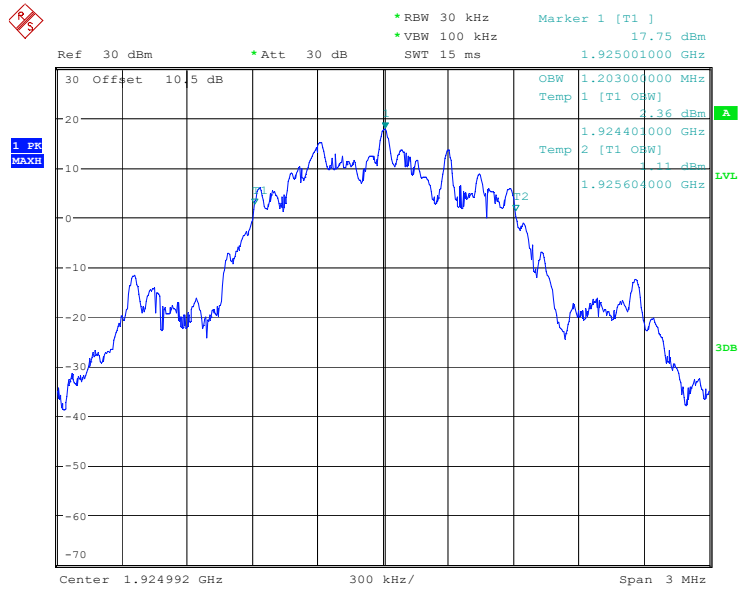

ProjectNo.:SZ1240103-00576E-PP Tester:Bruce Lin
 Date: 25.MAR.2024 22:19:59

High Channel

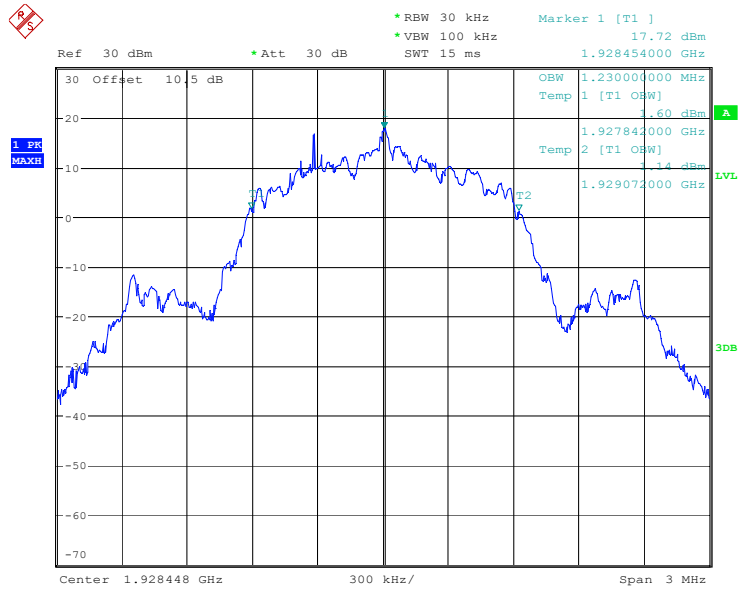

ProjectNo.:SZ1240103-00576E-PP Tester:Bruce Lin
 Date: 25.MAR.2024 22:34:08

26 dB Emission Bandwidth

Low Channel

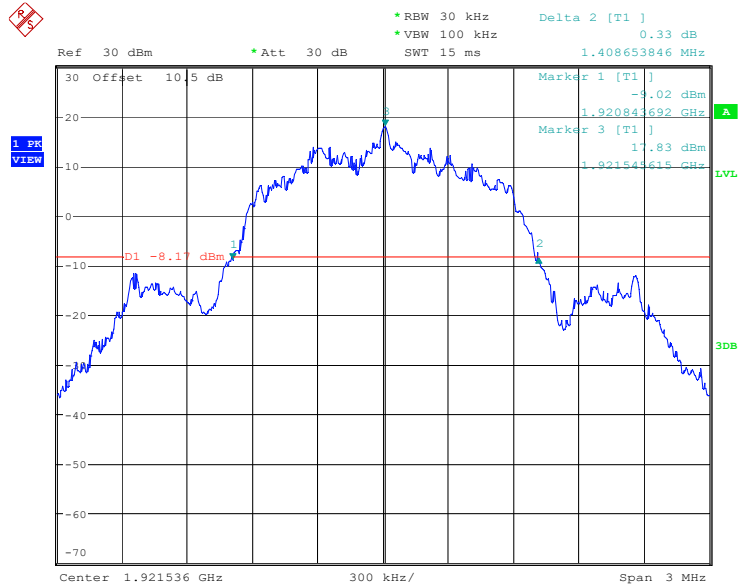

ProjectNo.:SZ1240103-00576E-PP Tester:Bruce Lin

Date: 25.MAR.2024 22:00:17

Middle Channel

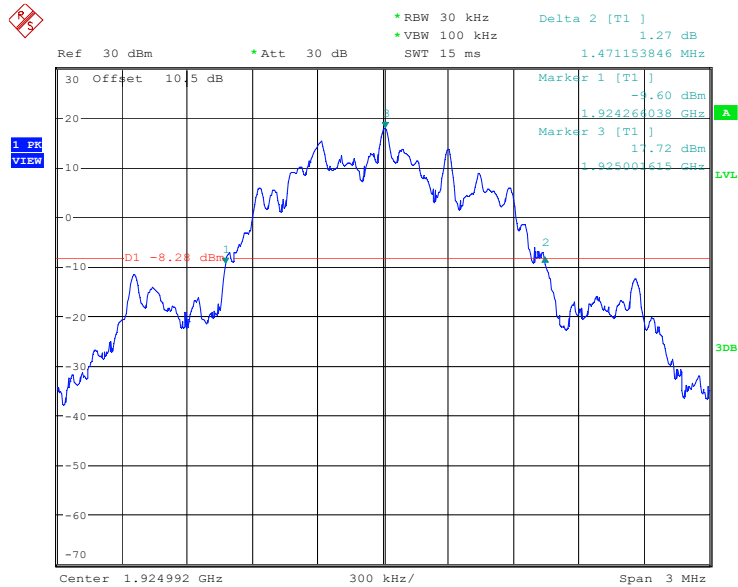

ProjectNo.:SZ1240103-00576E-PP Tester:Bruce Lin

Date: 25.MAR.2024 22:20:49

High Channel

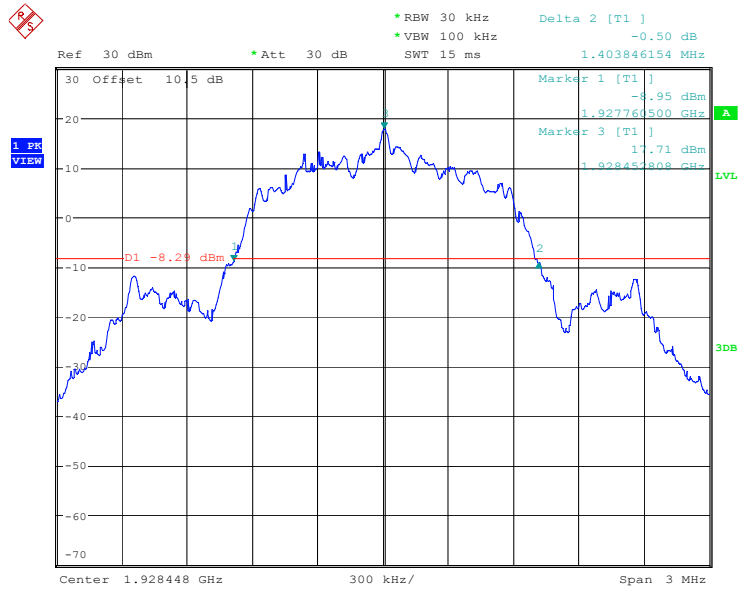

ProjectNo.:SZ1240103-00576E-PP Tester:Bruce Lin
Date: 25.MAR.2024 22:34:48

§ 15.319 (c) & RSS-213 §5.6 PEAK TRANSMIT POWER

Applicable Standard

The peak power output as measured over an interval of time equal to the frame rate or transmission burst of the device under all conditions of modulation. Usually this parameter is measured as a conducted emission by direct connection of a calibrated test instrument to the equipment under test. If the device cannot be connected directly, alternative techniques acceptable to the Commission may be used [47 CFR 15, subpart D, 15.303].

The peak transmit power is according to ANSI C63.17-2013 §6.1.2

Per FCC Part 15.319 (c) Peak transmit power shall not exceed 100 microwatts multiplied by the square root of the emission bandwidth in hertz. Peak transmit power must be measured over any interval of continuous transmission using instrumentation calibrated in terms of an rms-equivalent voltage. The measurement results shall be properly adjusted for any instrument limitations, such as detector response times, limited resolution bandwidth capability when compared to the emission bandwidth, sensitivity, etc., so as to obtain a true peak measurement for the emission in question over the full bandwidth of the channel.

Per FCC Part 15.319 (e), the peak transmit power shall be reduced by the amount in decibels that the maximum directional gain of the antenna exceeds 3 dBi.

Calculation of Peak Transmit Power Limit:

$$\text{Peak Transmit Power Limit} = 100\mu\text{W} \times (\text{EBW})^{1/2}$$

EBW is the transmit emission bandwidth in Hz determined in the other test item:

Peak transmit power shall not exceed 100 μW multiplied by the square root of the occupied bandwidth in hertz. The peak transmit power shall be reduced by the amount in decibels that the maximum directional gain of the antenna exceeds 3 dBi.

Test Procedure

Using the manufacturer’s information on occupied bandwidth set the spectrum analyzer as follows:

RBW	≥ Emission bandwidth
Video bandwidth	≥ RBW
Span	Zero
Center frequency	Nominal center frequency of channels
Amplitude scale	Log (linear may be used if analyzer has sufficient linear dynamic range and accuracy)
Detection	Peak detection
Trigger	Video
Sweep rate	Sufficiently rapid to permit the transmit pulse to be resolved accurately

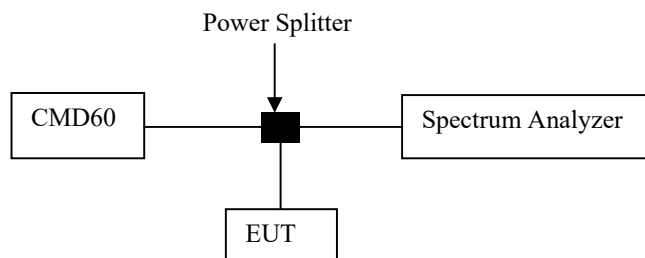

Test Data

Environmental Conditions

Temperature:	26.5 °C
Relative Humidity:	49 %
ATM Pressure:	101 kPa

The testing was performed by Bruce Lin on 2024-03-25.

Test mode: Transmitting:

Test Result: Compliant. Please refer to the following table and plots.

Channel	Frequency (MHz)	Peak Transmit Power (dBm)	FCC Limit (dBm)	ISED Limit (dBm)
Low	1921.536	19.94	20.74	20.39
Middle	1924.992	19.77	20.84	20.44
High	1928.448	19.75	20.74	20.44
For FCC: EBW Low channel = 1409000Hz, EBW Middle channel = 1471000 Hz, EBW High channel = 1404000 Hz Peak Transmit Power Limit = $100(\text{EBW})^{1/2} \mu\text{W}$				
For ISED: OBW Low channel = 1221000Hz, OBW Middle channel = 1203000 Hz, OBW High channel = 1230000 Hz Peak Transmit Power Limit = $100(\text{OBW})^{1/2} \mu\text{W}$				

Low Channel

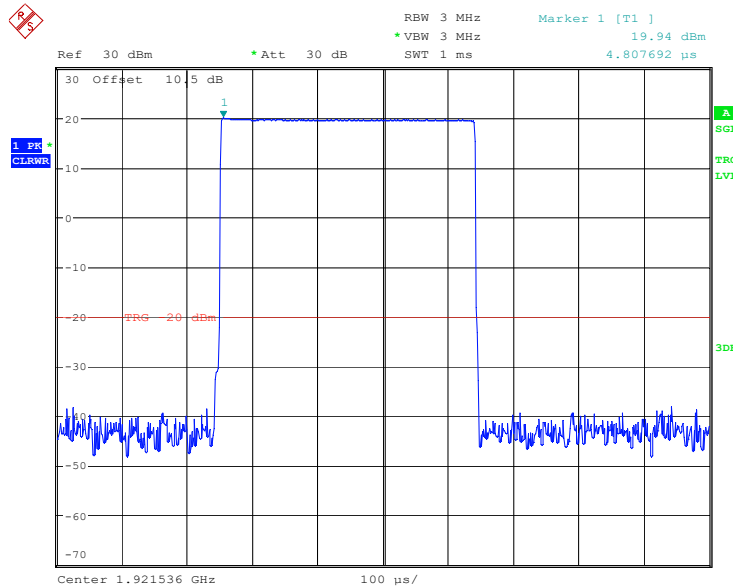

ProjectNo.:SZ1240103-00576E-PP Tester:Bruce Lin
Date: 25.MAR.2024 21:58:39

Middle Channel

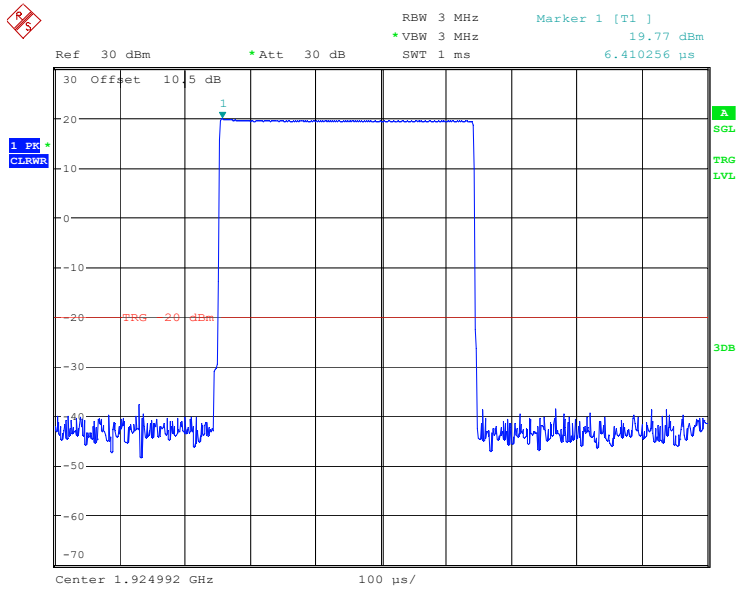

ProjectNo.:SZ1240103-00576E-PP Tester:Bruce Lin
Date: 25.MAR.2024 22:21:52

High Channel

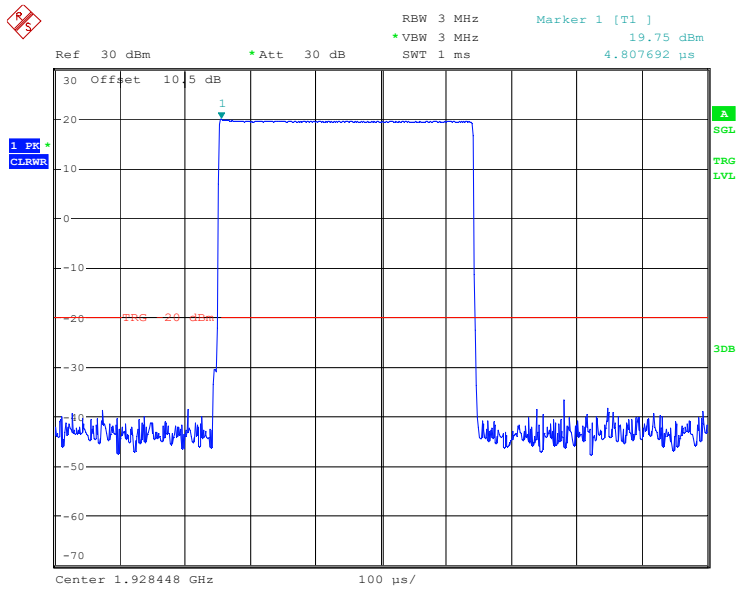

ProjectNo.:SZ1240103-00576E-PP Tester:Bruce Lin
Date: 25.MAR.2024 22:32:58

§ 15.319 (d) & RSS-213 §5.7 POWER SPECTRAL DENSITY

Applicable Standard

The average pulse energy in a 3 kHz bandwidth is divided by the pulse duration.

The power spectral density shall not exceed 3mW in any 3 kHz bandwidth as measured with a spectrum analyzer having a resolution bandwidth of 3 kHz.

The power spectral density is measured in accordance with ANSI C63.17-2013 Clause 6.1.5.

The peak-hold power spectral density of transmitters shall not exceed 12 mW per any 3 kHz bandwidth. As an alternative to the peak-hold power spectral density, the time-averaged power spectral density may be measured and it shall not exceed 3 mW per any 3 kHz bandwidth.

Test Procedure

Using the manufacturer’s information on occupied bandwidth set the spectrum analyzer as follows:

RBW	3 kHz
Video bandwidth	$\geq 3 \times \text{RBW}$
Span	Zero span at frequency with the maximum level (frequency determined in 6.1.3 if the same type of signal (continuous versus burst) was used in 6.1.3)
Center frequency	Spectral peak as determined in 6.1.3
Sweep time	For burst signals, sufficient to include essentially all of the maximum length burst at the output of a 3 kHz filter (e.g., maximum input burst duration plus 600 μs). For continuous signals, 20 ms.
Amplitude scale	Log power
Detection	Sample detection and averaged for a minimum of 100 sweeps
Trigger	External or internal

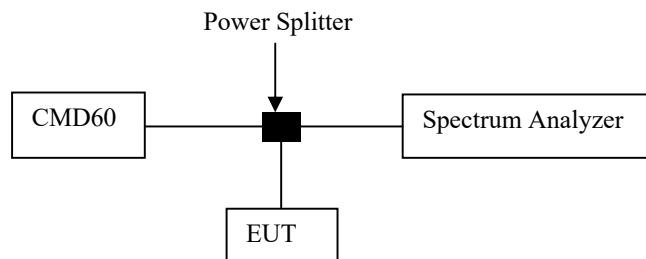

Test Data

Environmental Conditions

Temperature:	26.5 °C
Relative Humidity:	49 %
ATM Pressure:	101 kPa

The testing was performed by Bruce Lin on 2024-03-25.

Test mode: Transmitting

Test Result: Compliant

Please refer to following table and plots

Channel	Frequency (MHz)	Power Spectral Density		Limit (mW/3kHz)
		(dBm/3kHz)	(mW/3kHz)	
Low	1921.536	0.79	1.199	3
Middle	1924.992	0.79	1.199	3
High	1928.448	0.60	1.148	3

Low Channel

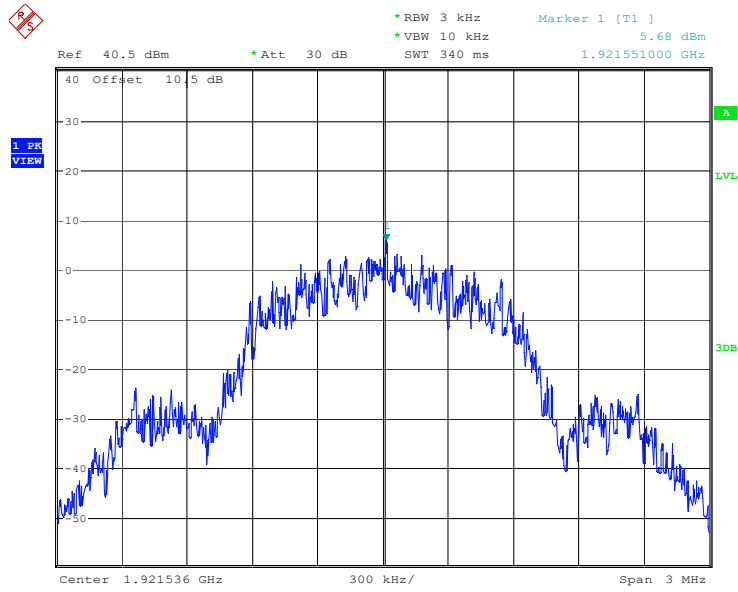

ProjectNo.:SZ1240103-00576E-PP Tester:Bruce Lin
Date: 25.MAR.2024 22:59:35

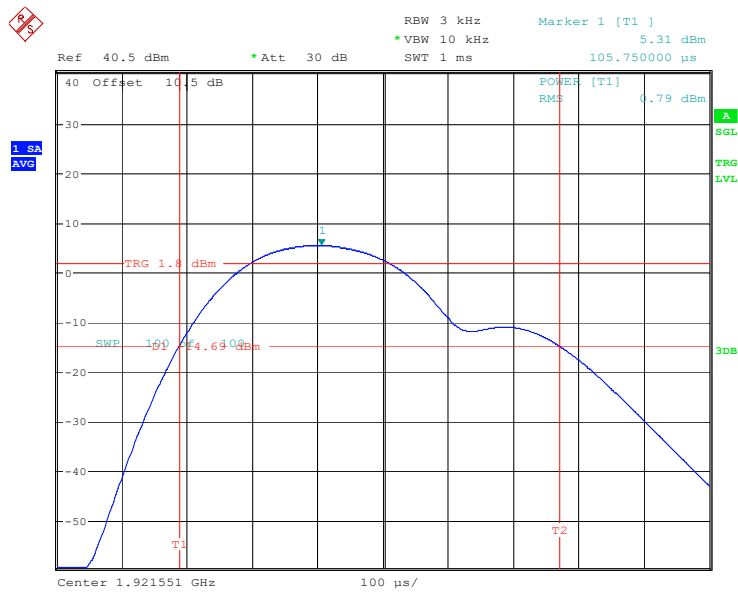

ProjectNo.:SZ1240103-00576E-PP Tester:Bruce Lin
Date: 25.MAR.2024 23:00:45

Middle Channel

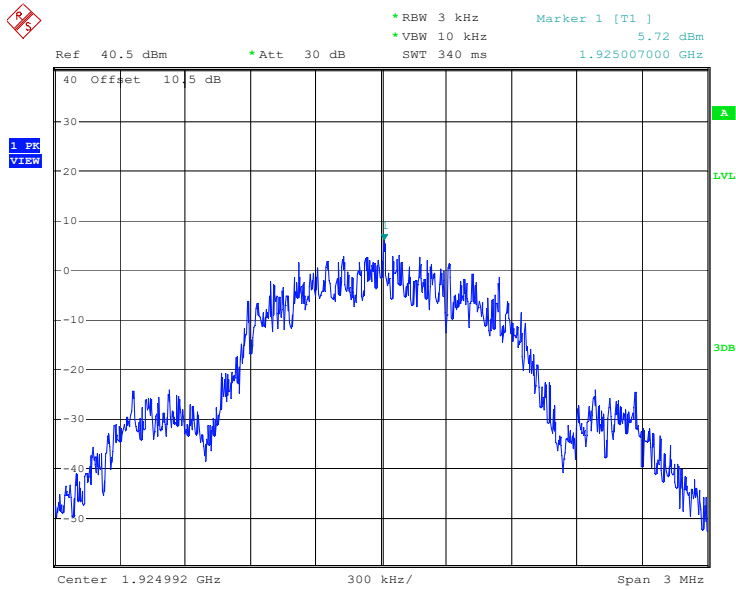

ProjectNo.:SZ1240103-00576E-PP Tester:Bruce Lin
Date: 25.MAR.2024 22:23:25

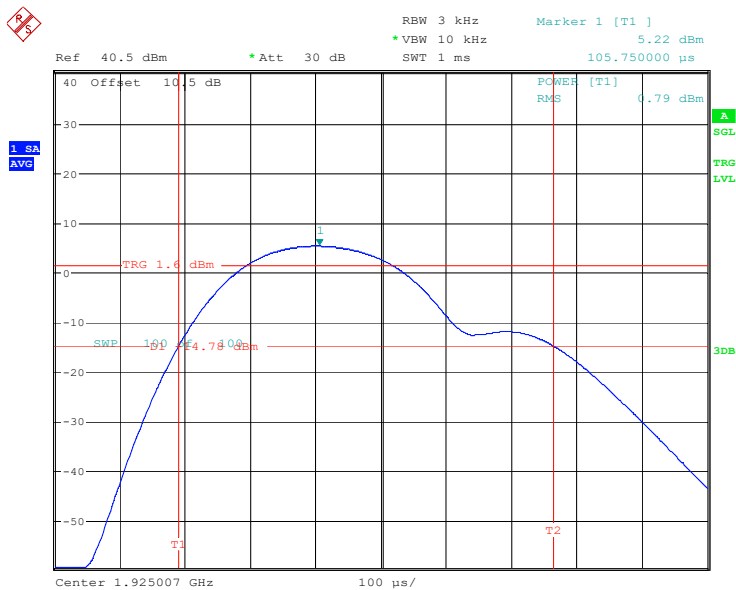

ProjectNo.:SZ1240103-00576E-PP Tester:Bruce Lin
Date: 25.MAR.2024 22:24:42

High Channel

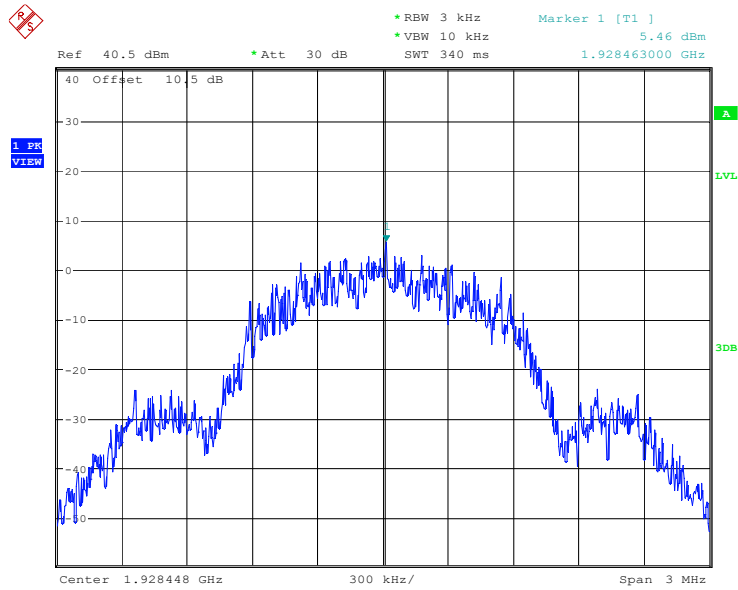

ProjectNo.:SZ1240103-00576E-PP Tester:Bruce Lin
Date: 25.MAR.2024 22:36:13

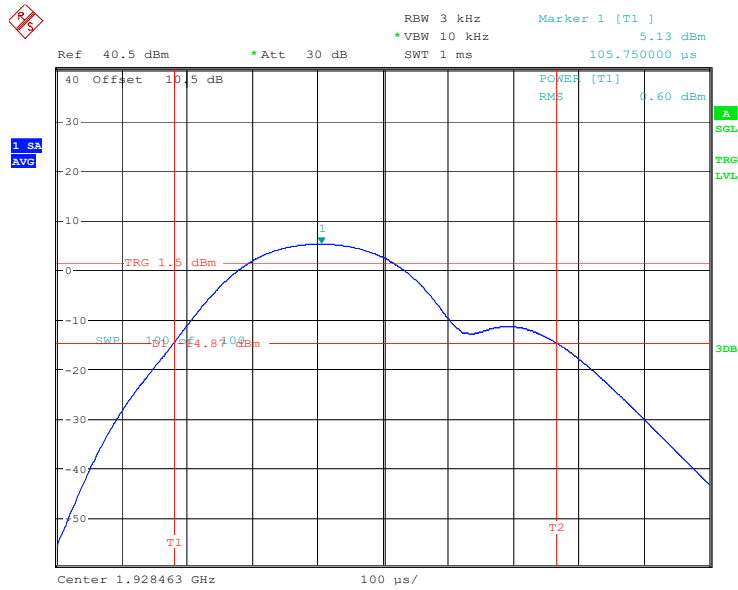

ProjectNo.:SZ1240103-00576E-PP Tester:Bruce Lin
Date: 25.MAR.2024 22:38:26

§15.319 (g), § 15.323 (d) & RSS-213 §5.8 EMISSION INSIDE AND OUTSIDE THE SUB-BAND

Applicable Standard

Emissions inside the sub-band must comply with the following emission mask:

1. In the bands between 1B and 2B measured from the center of the emission bandwidth the total power emitted by the device shall be at least 30 dB below the transmit power permitted for that device;
2. in the bands between 2B and 3B measured from the center of the emission bandwidth the total power emitted by an intentional radiator shall be at least 50 dB below the transmit power permitted for that radiator;
3. in the bands between 3B and the sub-band edge the total power emitted by an intentional radiator in the measurement bandwidth shall be at least 60 dB below the transmit power permitted for that radiator.

Where B = emission bandwidth

Emission Outside the sub-band shall be attenuated below a reference power of 112 mw (20.5 dBm) as follows:

1. 30 dB between the sub-band and 1.25 MHz above or below the sub-band;
2. 50 dB between 1.25 and 2.5 MHz above or below the sub-band;
3. 60 dB at 2.5 MHz or greater above or below the sub-band.

Emissions outside the 1920-1930 MHz Band

Emissions outside the 1920-1930 MHz band shall be attenuated below a reference power of 112 milliwatts (-9.5 dBW) by at least:

- 30 dB between the band edges and 1.25 MHz above and below the band edges;
- 50 dB between 1.25 MHz and 2.5 MHz above or below the band edges; and
- 60 dB at 2.5 MHz or greater above or below the band edges.

Emissions inside the 1920-1930 MHz Band

Emissions inside the 1920-1930 MHz band shall be attenuated below the transmit power permitted for that device, as follows:

- 30 dB between the frequencies 1B and 2B measured from the centre of the occupied bandwidth;
- 50 dB between the frequencies 2B and 3B measured from the centre of the occupied bandwidth; and
- 60 dB between the frequencies 3B and band edge, where B is the occupied bandwidth in hertz.

Test Procedure

According to ANSI C63.17.2013 Clause 6.1.6.

In-band emission:

Spectrum analyzer settings for measuring in-band emission

RBW	Approximately 1% of the emission bandwidth (<i>B</i>)
Video bandwidth	3 × RBW
Sweep time	The sweep time shall be sufficiently slow that the swept frequency rate shall not exceed one RBW per three transmit bursts.
Number of sweeps	Sufficient to stabilize the trace
Amplitude scale	Log
Detection	Peak detection and max hold enabled
Span	Approximately equal to 3.5 <i>B</i>

Out-band emission:

RBW	30kHz
Video bandwidth	100kHz
Center frequency	Nominal center frequency of channels
Amplitude scale	Log (linear may be used if analyzer has sufficient linear dynamic range and accuracy)
Detection	Peak detection

RF Conducted Emission:

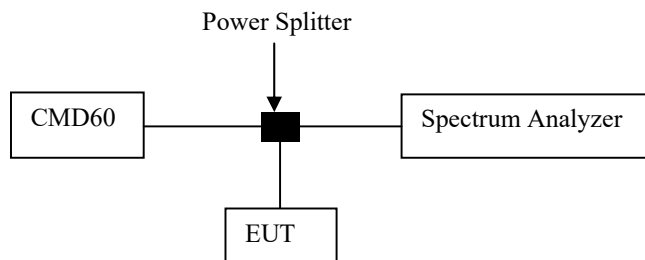

Spurious radiated emission set up:

9 kHz-30MHz:

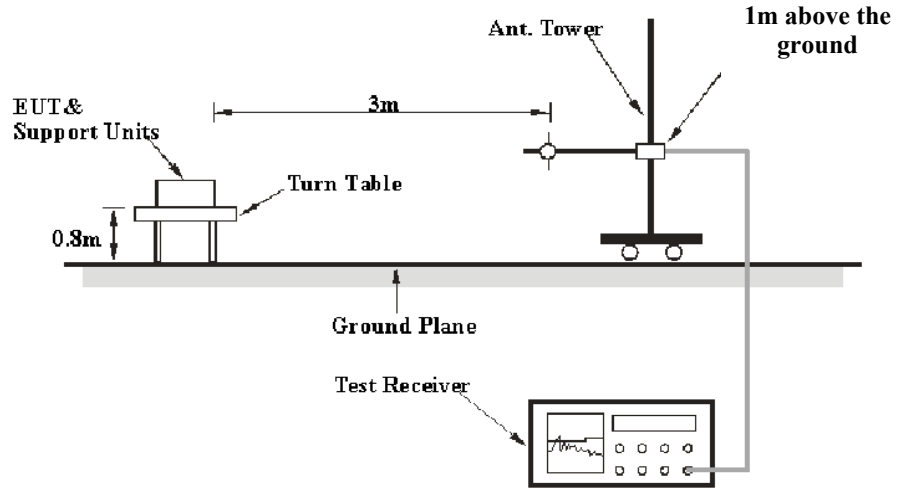

30MHz-1GHz:

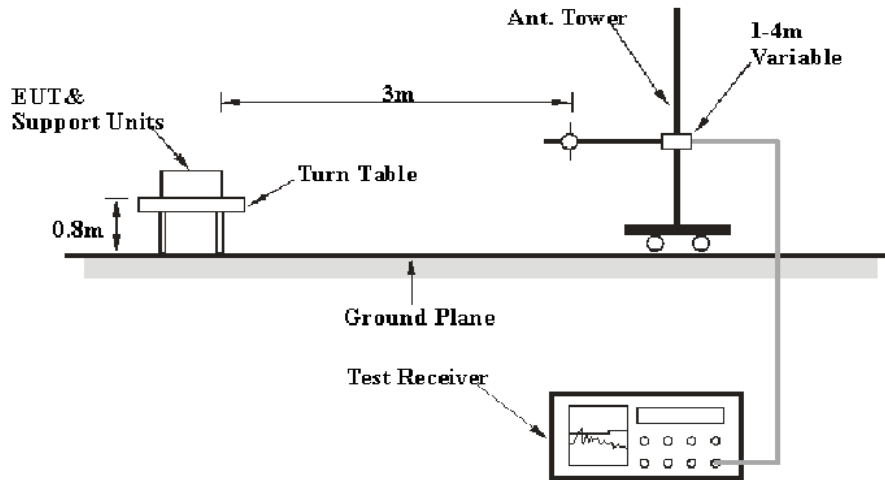

Above 1GHz:

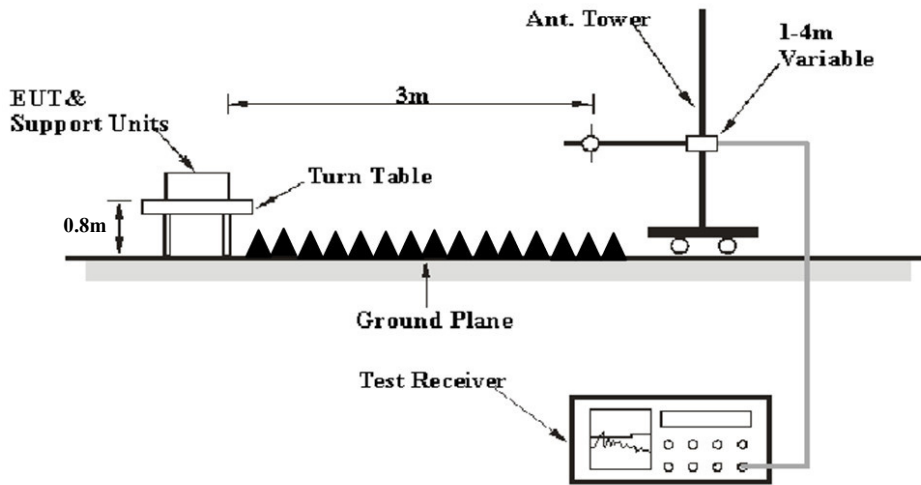

The radiated emission tests were performed in the 3 meters test site.

EMI Test Receiver & Spectrum Analyzer Setup

Frequency Range	RBW	Video B/W	IF B/W	Measurement
9 kHz – 150 kHz	/	/	200 Hz	QP
	300 Hz	1 kHz	/	PK
150 kHz – 30 MHz	/	/	9 kHz	QP
	10 kHz	30 kHz	/	PK
30 MHz – 1000 MHz	/	/	120 kHz	QP
	100 kHz	300 kHz	/	PK
Above 1 GHz*	1MHz	3 MHz	/	PK
	1MHz	10Hz	/	Average

If the maximized peak measured value complies with under the QP/Average limit more than 6dB, then it is unnecessary to perform an QP/Average measurement.

For the average emission of Fundamental and harmonic, it was calculated by the below formula:

$$\text{Average} = \text{Peak Measurement} + \text{Duty Cycle Corrected Factor}$$

Test Procedure

Maximizing procedure was performed on the highest emissions to ensure that the EUT complied with all installation combinations.

All final data was recorded in Quasi-peak detection mode except for the frequency bands 9–90 kHz, 110–490 kHz and above 1000 MHz, average detection modes for frequency bands 9–90 kHz and 110–490 kHz, peak and average detection modes for frequencies above 1 GHz.

For 9 kHz-30MHz, the report shall list the six emissions with the smallest margin relative to the limit, for each of the three antenna orientations (parallel, perpendicular, and ground-parallel) unless the margin is greater than 20 dB.

If the maximized peak measured value complies with under the QP/Average limit more than 6dB, then it is unnecessary to perform an QP/Average measurement.

Factor & Over Limit/Margin Calculation

The Factor is calculated by adding the Antenna Factor and Cable Loss, and subtracting the Amplifier Gain. The basic equation is as follows:

$$\text{Factor} = \text{Antenna Factor} + \text{Cable Loss} - \text{Amplifier Gain}$$

The “**Over Limit/Margin**” column of the following data tables indicates the degree of compliance with the applicable limit. For example, an Over Limit/margin of -7dB means the emission is 7dB below the limit. The equation for calculation is as follows:

$$\begin{aligned} \text{Over Limit/Margin} &= \text{Level/Corrected Amplitude} - \text{Limit} \\ \text{Level / Corrected Amplitude} &= \text{Read Level} + \text{Factor} \end{aligned}$$

Test Data

Environmental Conditions

Temperature:	22~26.5 °C
Relative Humidity:	44~56 %
ATM Pressure:	101 kPa

The testing was performed by Anson Su on 2024-02-23 for below 1GHz, Dylan Yang on 2024-02-08 for above 1GHz and Bruce Lin on 2024-03-25 for RF conducted.

Test mode: Transmitting

Test Result: Compliant

Please refer to following plots

Note: For the spurious emission below 30MHz, the emissions are 20dB below the limit which are not recorded.

FCC:

Low Channel (Unwanted Emission inside the Sub-band)

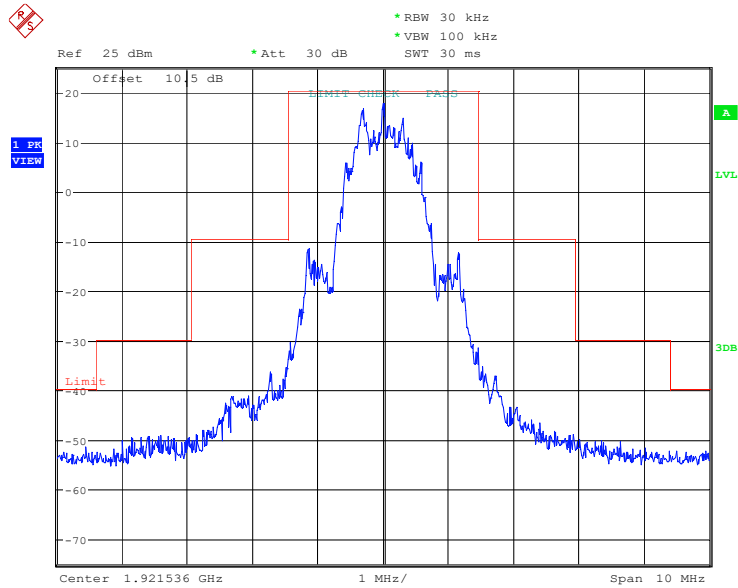

ProjectNo.:SZ1240103-00576E-PP Tester:Bruce Lin
Date: 25.MAR.2024 22:14:37

Middle Channel (Unwanted Emission inside the Sub-band)

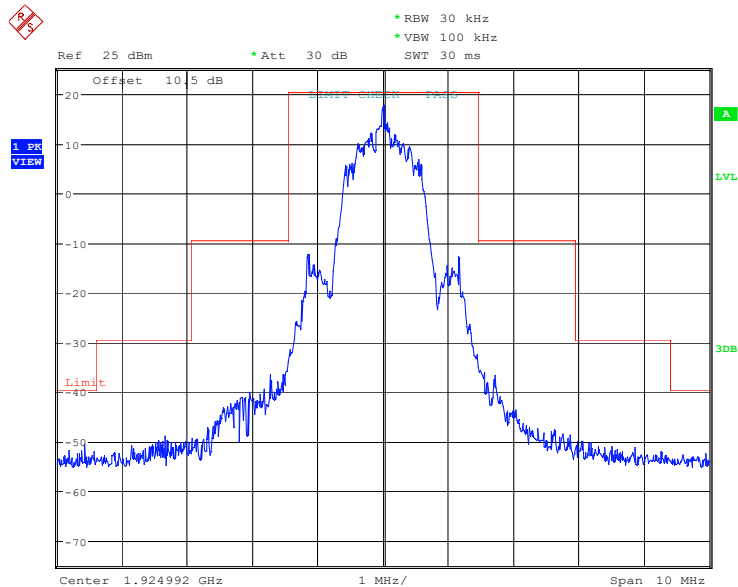

ProjectNo.:SZ1240103-00576E-PP Tester:Bruce Lin
Date: 25.MAR.2024 22:31:31

High Channel (Unwanted Emission inside the Sub-band)

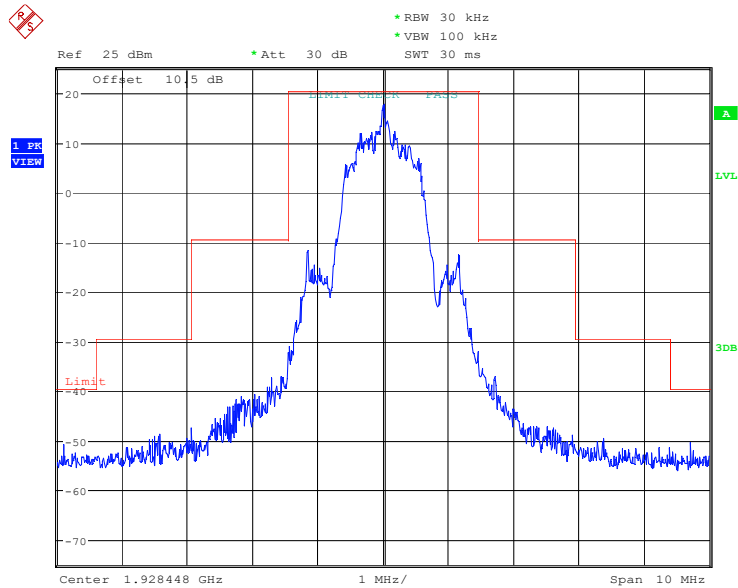

ProjectNo.:SZ1240103-00576E-PP Tester:Bruce Lin
Date: 25.MAR.2024 22:46:05

ISED:

Low Channel (Unwanted Emission inside the Sub-band)

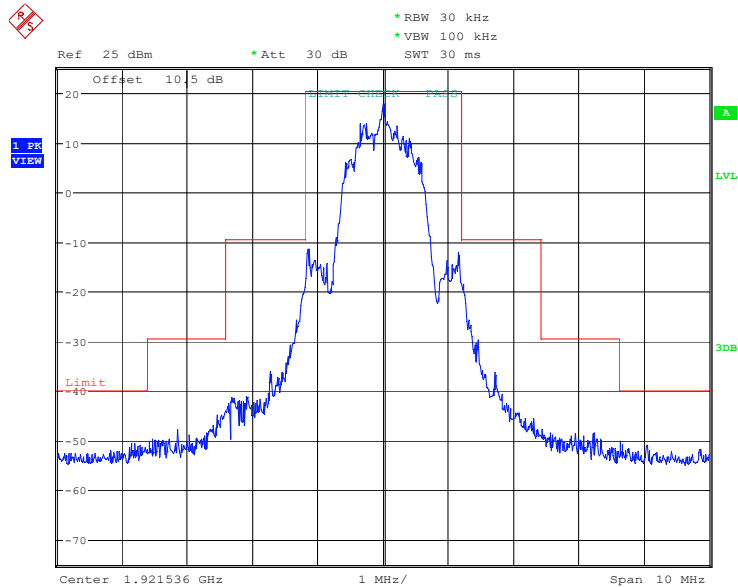

ProjectNo.:SZ1240103-00576E-PP Tester:Bruce Lin
Date: 25.MAR.2024 22:05:53

Middle Channel (Unwanted Emission inside the Sub-band)

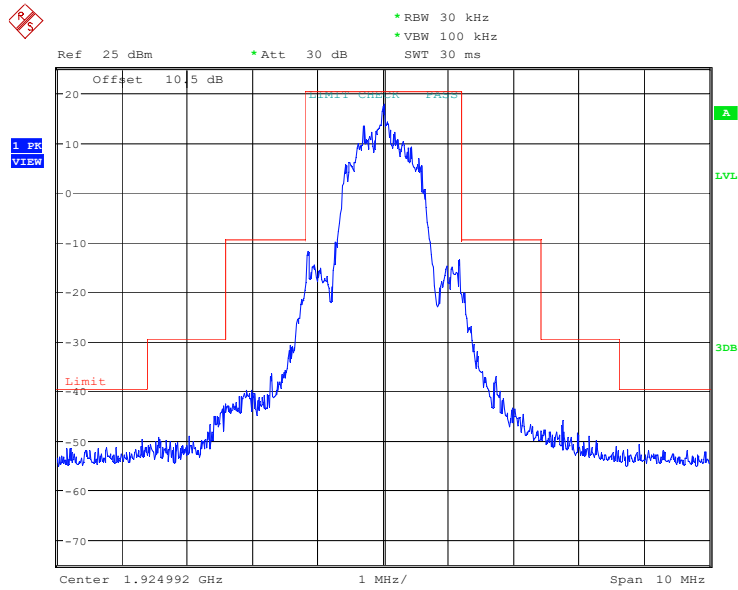

ProjectNo.:SZ1240103-00576E-PP Tester:Bruce Lin
Date: 25.MAR.2024 22:26:33

High Channel (Unwanted Emission inside the Sub-band)

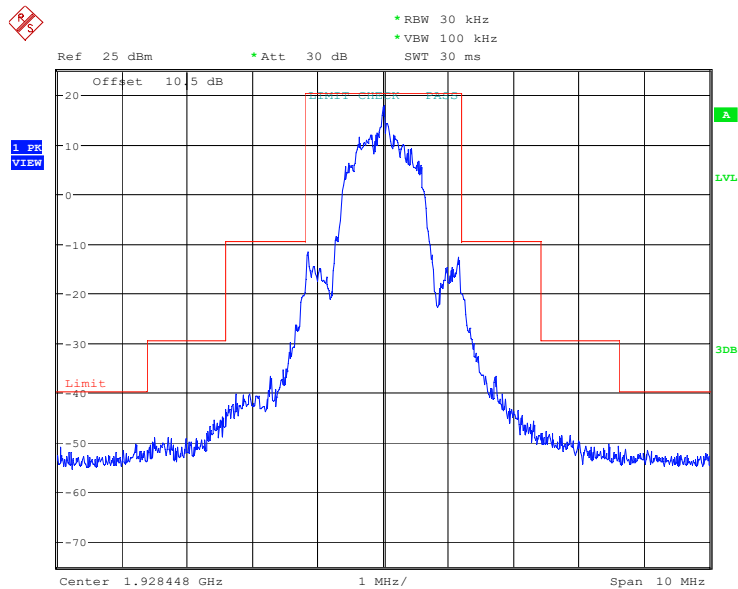

ProjectNo.:SZ1240103-00576E-PP Tester:Bruce Lin
Date: 25.MAR.2024 22:39:37

Low Channel (Unwanted Emission outside the Sub-band)

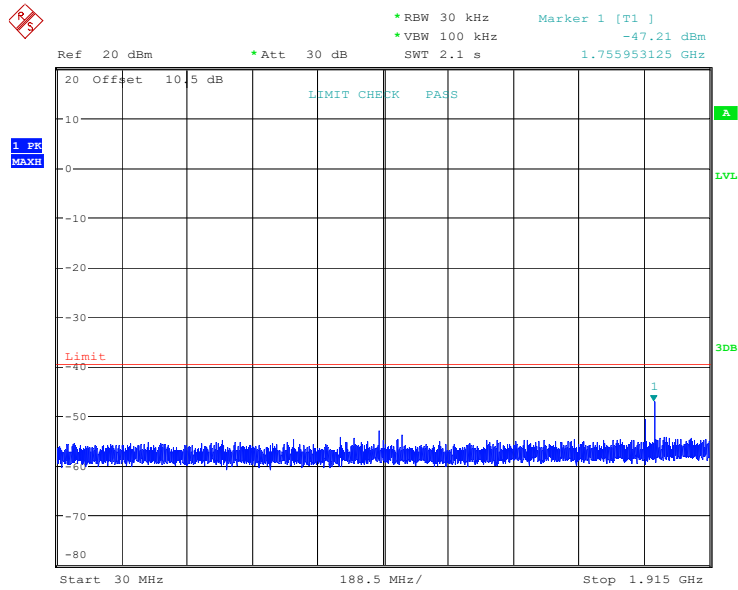

ProjectNo.:SZ1240103-00576E-PP Tester:Bruce Lin
Date: 25.MAR.2024 22:06:34

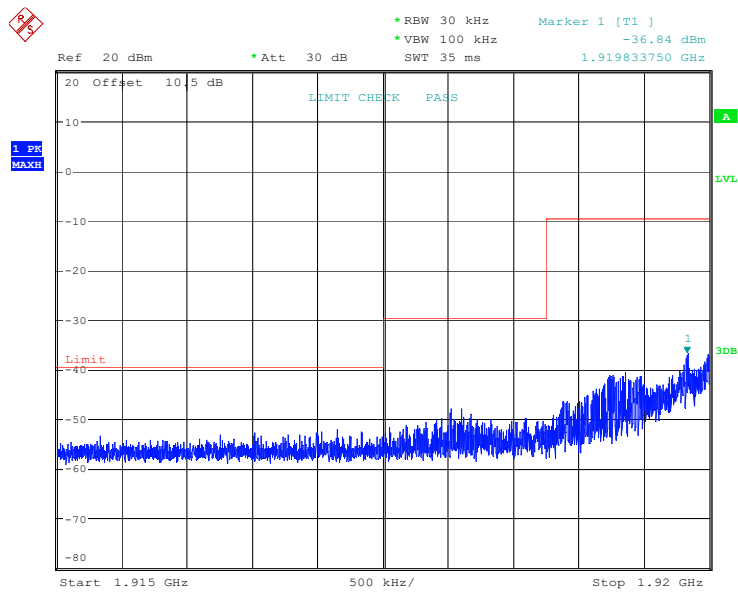

ProjectNo.:SZ1240103-00576E-PP Tester:Bruce Lin
Date: 25.MAR.2024 22:07:16

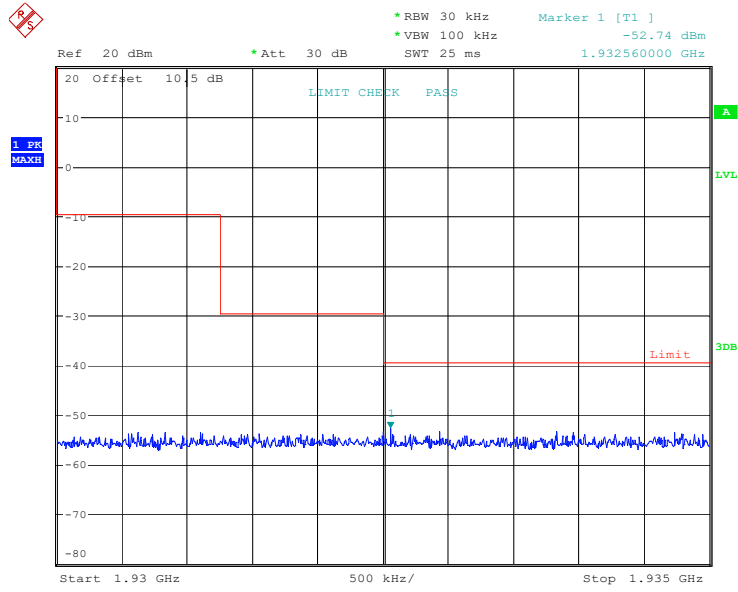

ProjectNo.:SZ1240103-00576E-PP Tester:Bruce Lin
Date: 25.MAR.2024 22:07:51

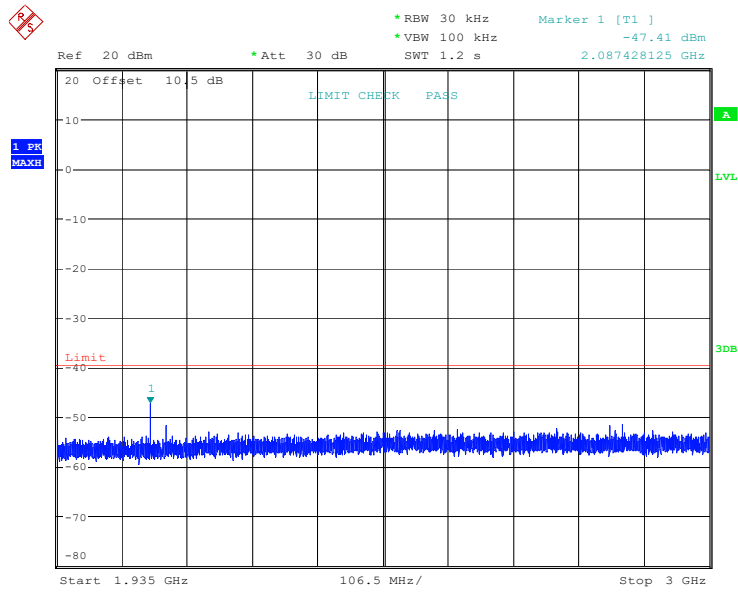

ProjectNo.:SZ1240103-00576E-PP Tester:Bruce Lin
Date: 25.MAR.2024 22:08:32

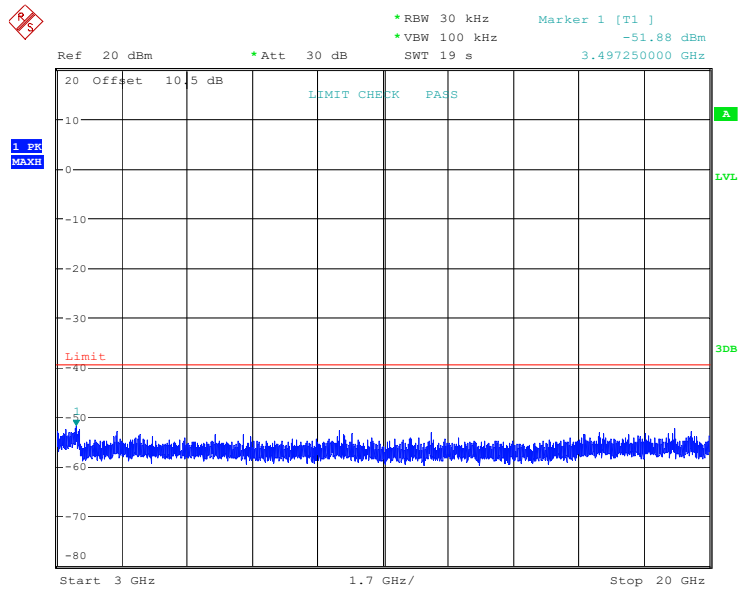

ProjectNo.:SZ1240103-00576E-PP Tester:Bruce Lin
Date: 25.MAR.2024 22:09:34

Middle Channel (Unwanted Emission outside the Sub-band)

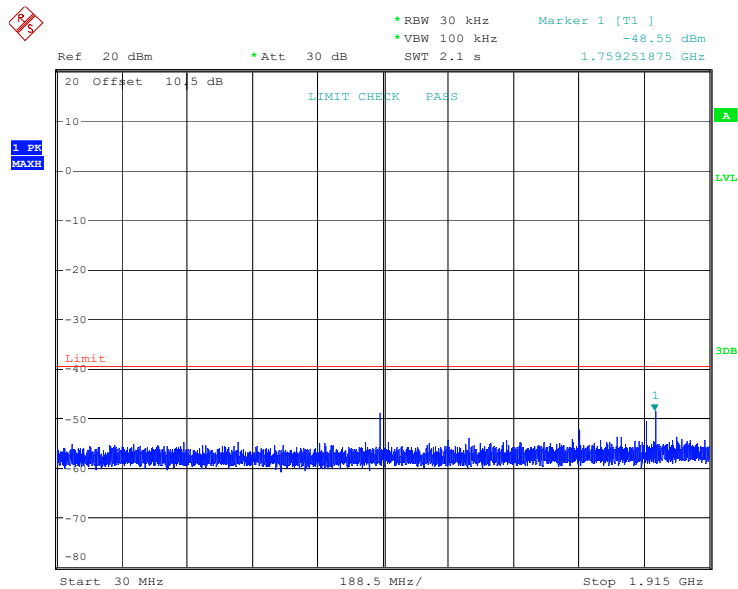

ProjectNo.:SZ1240103-00576E-PP Tester:Bruce Lin
Date: 25.MAR.2024 22:27:14

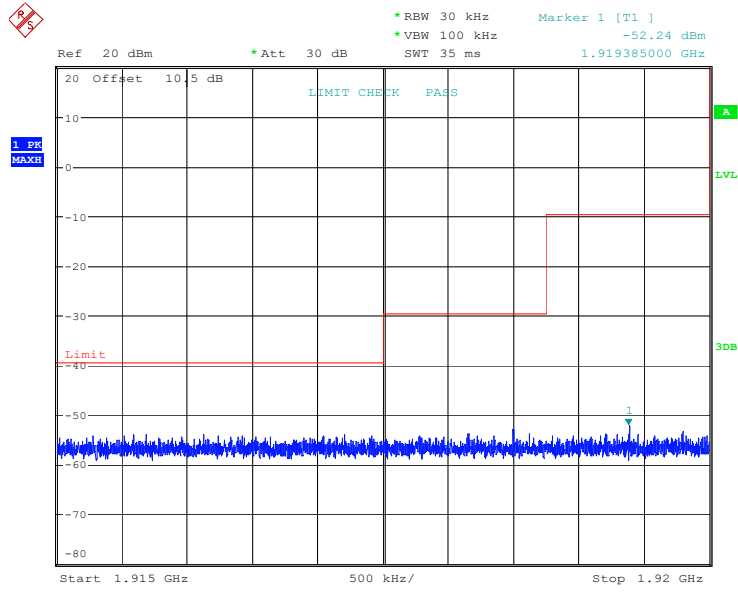

ProjectNo.:SZ1240103-00576E-PP Tester:Bruce Lin
Date: 25.MAR.2024 22:27:56

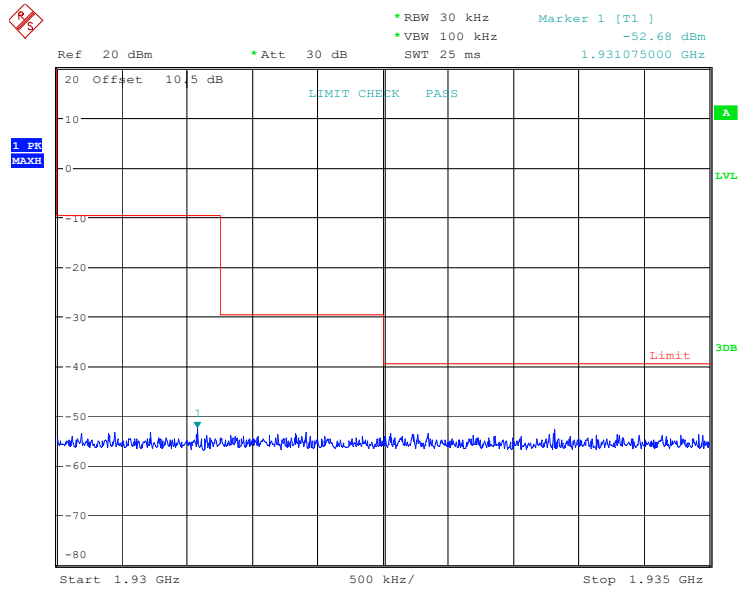

ProjectNo.:SZ1240103-00576E-PP Tester:Bruce Lin
Date: 25.MAR.2024 22:28:31

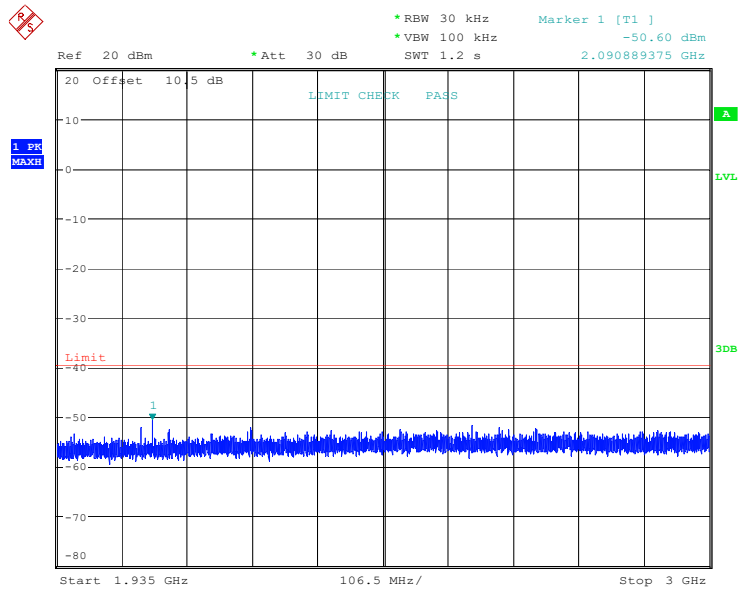

ProjectNo.:SZ1240103-00576E-PP Tester:Bruce Lin
Date: 25.MAR.2024 22:29:13

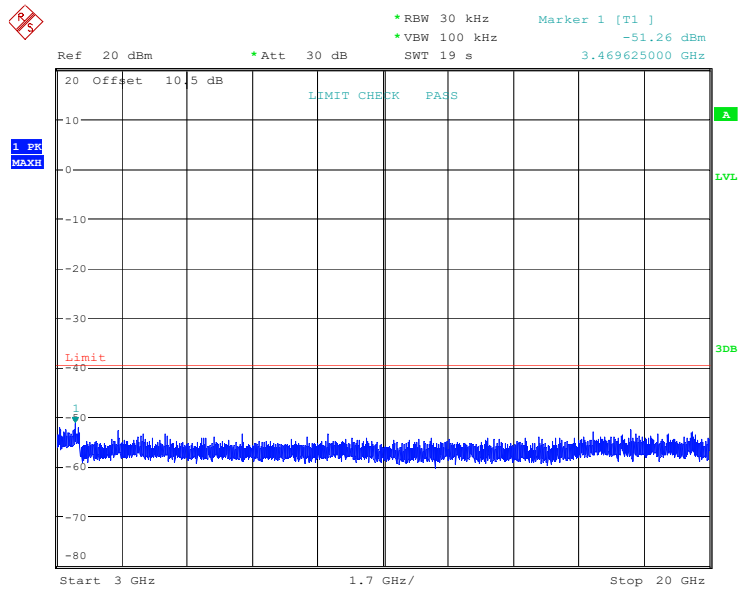

ProjectNo.:SZ1240103-00576E-PP Tester:Bruce Lin
Date: 25.MAR.2024 22:30:14

High Channel (Unwanted Emission outside the Sub-band)

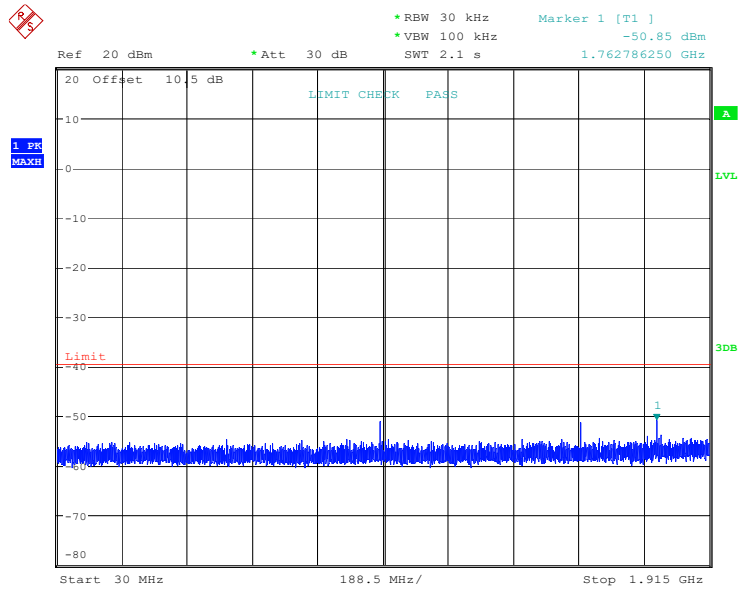

ProjectNo.:SZ1240103-00576E-PP Tester:Bruce Lin
Date: 25.MAR.2024 22:40:19

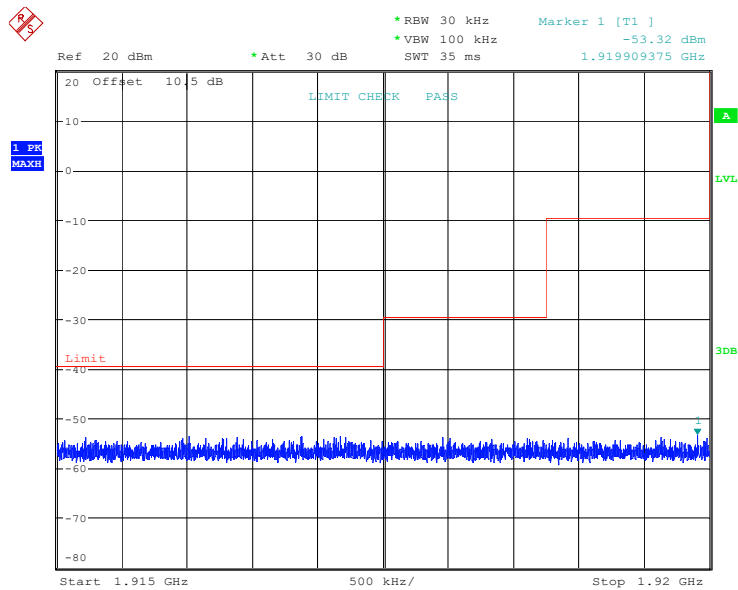

ProjectNo.:SZ1240103-00576E-PP Tester:Bruce Lin
Date: 25.MAR.2024 22:41:00

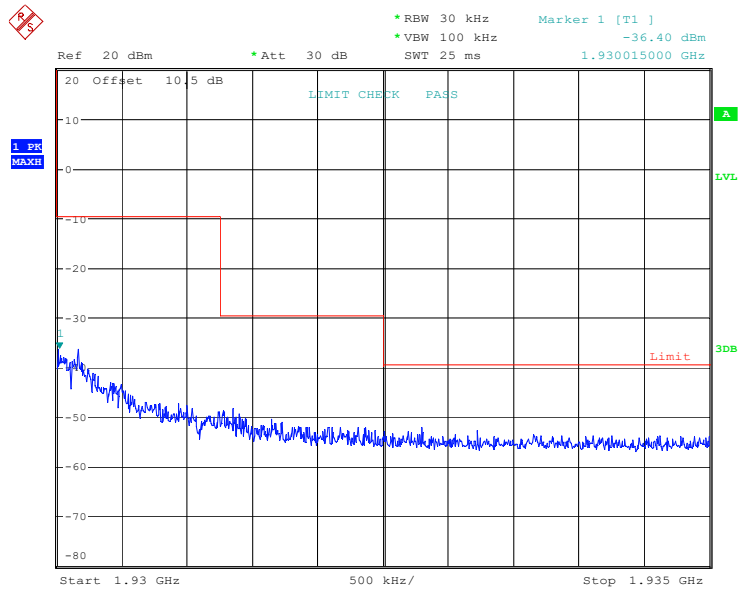

ProjectNo.:SZ1240103-00576E-PP Tester:Bruce Lin
Date: 25.MAR.2024 22:41:35

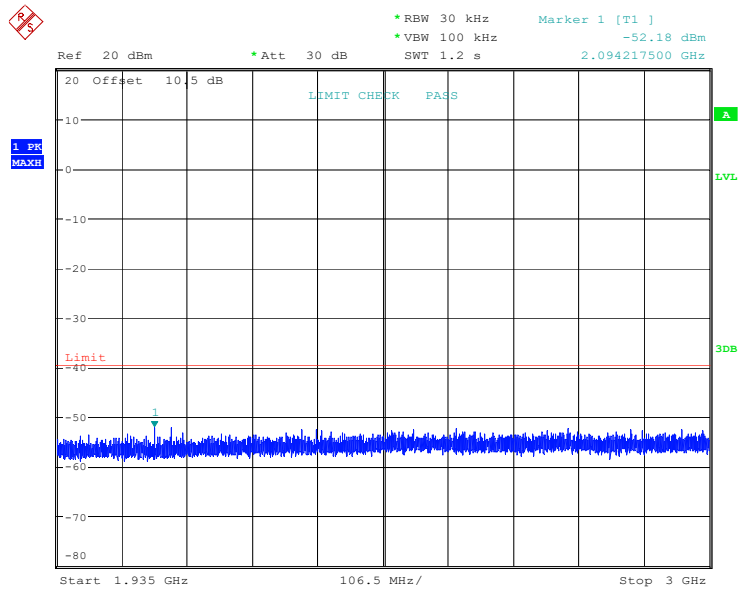

ProjectNo.:SZ1240103-00576E-PP Tester:Bruce Lin
Date: 25.MAR.2024 22:42:17

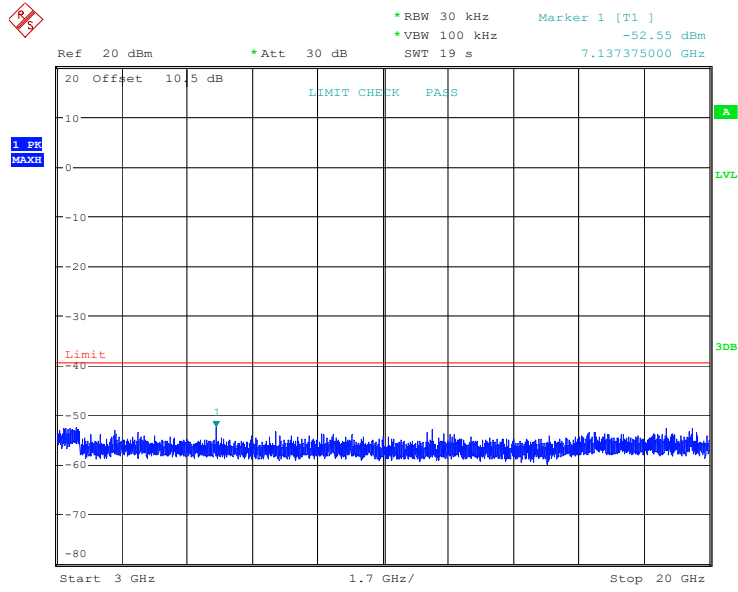

ProjectNo.:SZ1240103-00576E-PP Tester:Bruce Lin
Date: 25.MAR.2024 22:43:18

30MHz-1GHz: (Maximum output power mode, Low channel)

Horizontal

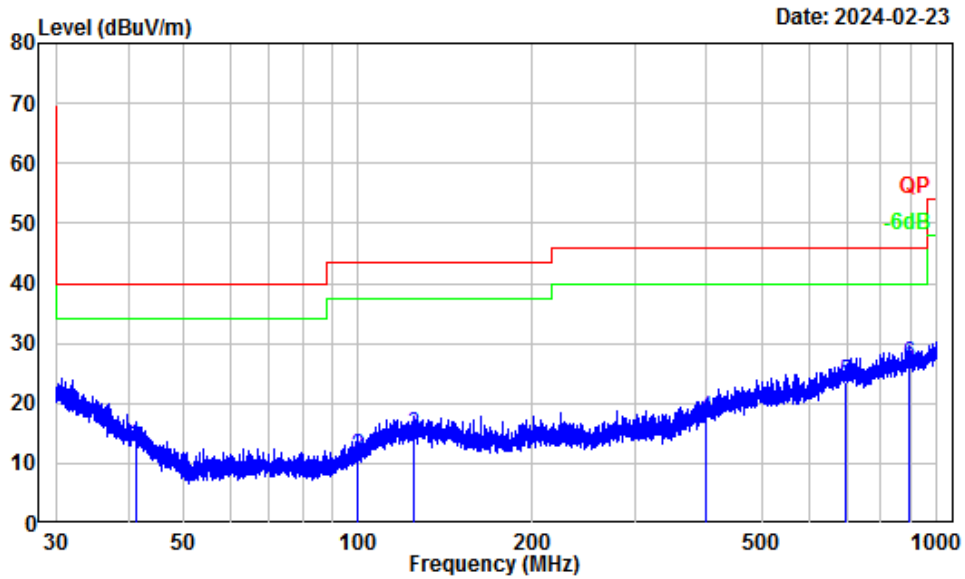

Site : chamber
 Condition : 3m Horizontal
 Project Number: SZ1240103-00576E-RF
 Note : GFSK
 Tester : Anson Su

	Freq	Factor	Read Level	Level	Limit Line	Over Limit	Remark
	MHz	dB/m	dBuV	dBuV/m	dBuV/m	dB	
1	41.17	-11.14	24.08	12.94	40.00	-27.06	QP
2	99.44	-13.89	25.04	11.15	43.50	-32.35	QP
3	124.30	-10.32	24.98	14.66	43.50	-28.84	QP
4	399.91	-7.36	24.78	17.42	46.00	-28.58	QP
5	697.47	-1.56	25.03	23.47	46.00	-22.53	QP
6	895.03	0.93	25.68	26.61	46.00	-19.39	QP

Vertical

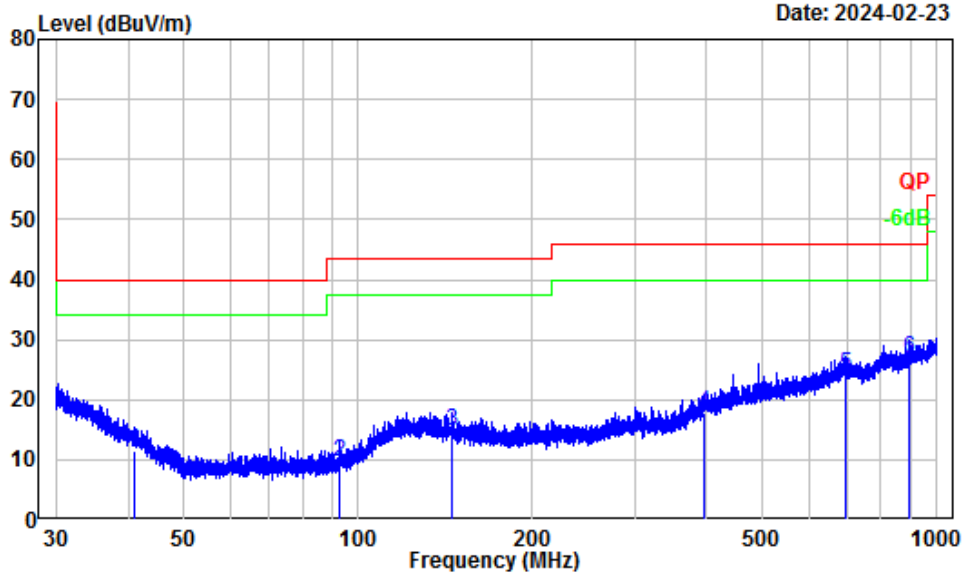

Site : chamber
 Condition : 3m Vertical
 Project Number: SZ1240103-00576E-RF
 Note : GFSK
 Tester : Anson Su

	Freq	Factor	Read Level	Level	Limit Line	Over Limit	Remark
	MHz	dB/m	dBuV	dBuV/m	dBuV/m	dB	
1	41.04	-12.48	23.95	11.47	40.00	-28.53	QP
2	93.03	-16.71	26.38	9.67	43.50	-33.83	QP
3	144.84	-11.48	26.25	14.77	43.50	-28.73	QP
4	395.55	-7.79	25.60	17.81	46.00	-28.19	QP
5	695.94	-1.98	26.15	24.17	46.00	-21.83	QP
6	898.57	0.59	26.29	26.88	46.00	-19.12	QP

Above 1GHz:

Frequency (MHz)	Receiver		Polar (H/V)	Factor (dB/m)	Corrected Amplitude (dBµV/m)	Limit (dBµV/m)	Margin (dB)
	Reading (dBµV)	PK/Ave					
Low Channel							
1921.536	117.99	PK	H	-6.39	111.60	/	/
1921.536	112.56	PK	V	-6.39	106.17	/	/
3843.08	65.38	PK	H	-0.78	64.60	74	-9.40
3843.08	60.46	PK	V	-0.78	59.68	74	-14.32
Middle Channel							
1924.992	117.82	PK	H	-6.39	111.43	/	/
1924.992	112.52	PK	V	-6.39	106.13	/	/
3849.98	65.78	PK	H	-1.14	64.64	74	-9.36
3849.98	60.22	PK	V	-1.14	59.08	74	-14.92
High Channel							
1928.448	117.68	PK	H	-6.39	111.29	/	/
1928.448	112.53	PK	V	-6.39	106.14	/	/
3856.90	66.31	PK	H	-0.74	65.57	74	-8.43
3856.90	59.51	PK	V	-0.74	58.77	74	-15.23

Note:

Factor = Antenna factor (RX) + Cable Loss – Amplifier Factor

Corrected Amplitude = Factor + Reading

Margin = Corrected. Amplitude - Limit

Average level= Peak level+ Duty Cycle Corrected Factor

All other spurious emission are 20dB below the limit or the noise floor which are not recorded.

Field Strength of Average							
Frequency (MHz)	Peak Measurement @3m (dBµV/m)	Polar (H/V)	Duty Cycle Correction Factor (dB)	Corrected Amplitude (dBµV/m)	FCC Part 15D/RSS-213		
					Limit (dBµV/m)	Margin (dB)	Comment
1921.536MHz							
1921.536	111.6	H	-28.02	83.58	/	/	Fundamental
1921.536	106.17	V	-28.02	78.15	/	/	Fundamental
3843.08	64.6	H	-28.02	36.58	54	-17.42	Harmonic
3843.08	59.68	V	-28.02	31.66	54	-22.34	Harmonic
1924.992MHz							
1924.992	111.43	H	-28.02	83.41	/	/	Fundamental
1924.992	106.13	V	-28.02	78.11	/	/	Fundamental
3849.98	64.64	H	-28.02	36.62	54	-17.38	Harmonic
3849.98	59.08	V	-28.02	31.06	54	-22.94	Harmonic
1928.448MHz							
1928.448	111.29	H	-28.02	83.27	/	/	Fundamental
1928.448	106.14	V	-28.02	78.12	/	/	Fundamental
3856.9	65.57	H	-28.02	37.55	54	-16.45	Harmonic
3856.9	58.77	V	-28.02	30.75	54	-23.25	Harmonic

Duty cycle:

Ton =0.4ms

Tp = 10.08ms

Duty cycle = Ton/Tp = 0.4/10.08=0.0397

Duty Cycle Corrected Factor = 20lg (Duty cycle) = 20lg0.0397= -28.02

Duty cycle

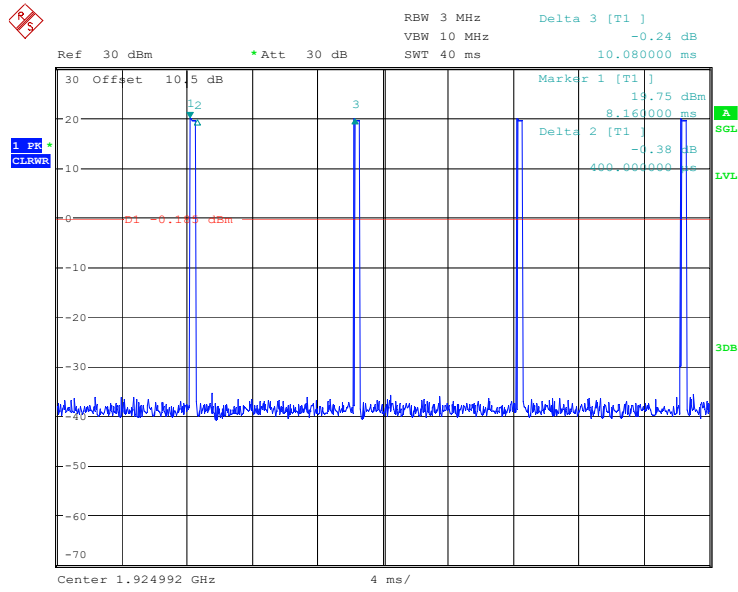

ProjectNo.:SZ1240103-00576E-PP Tester:Bruce Lin
Date: 25.MAR.2024 22:18:39

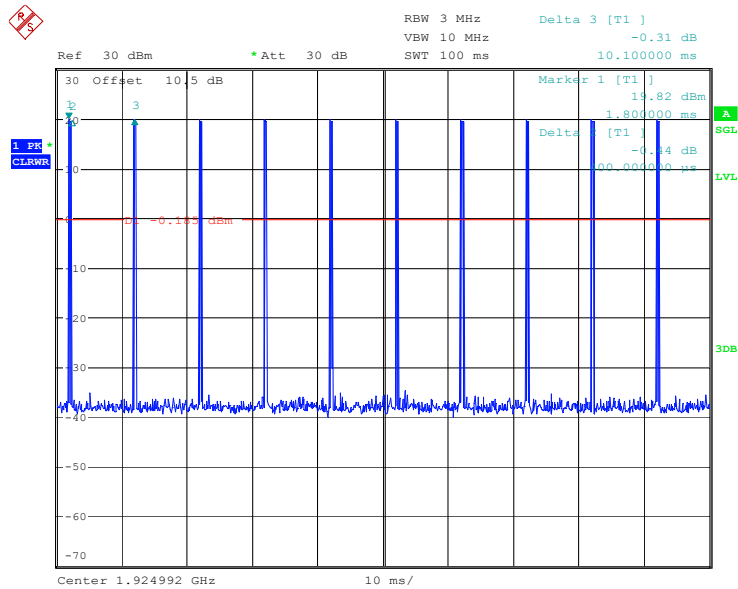

ProjectNo.:SZ1240103-00576E-PP Tester:Bruce Lin
Date: 25.MAR.2024 22:18:52

Listed with the worst harmonic margin test plot:

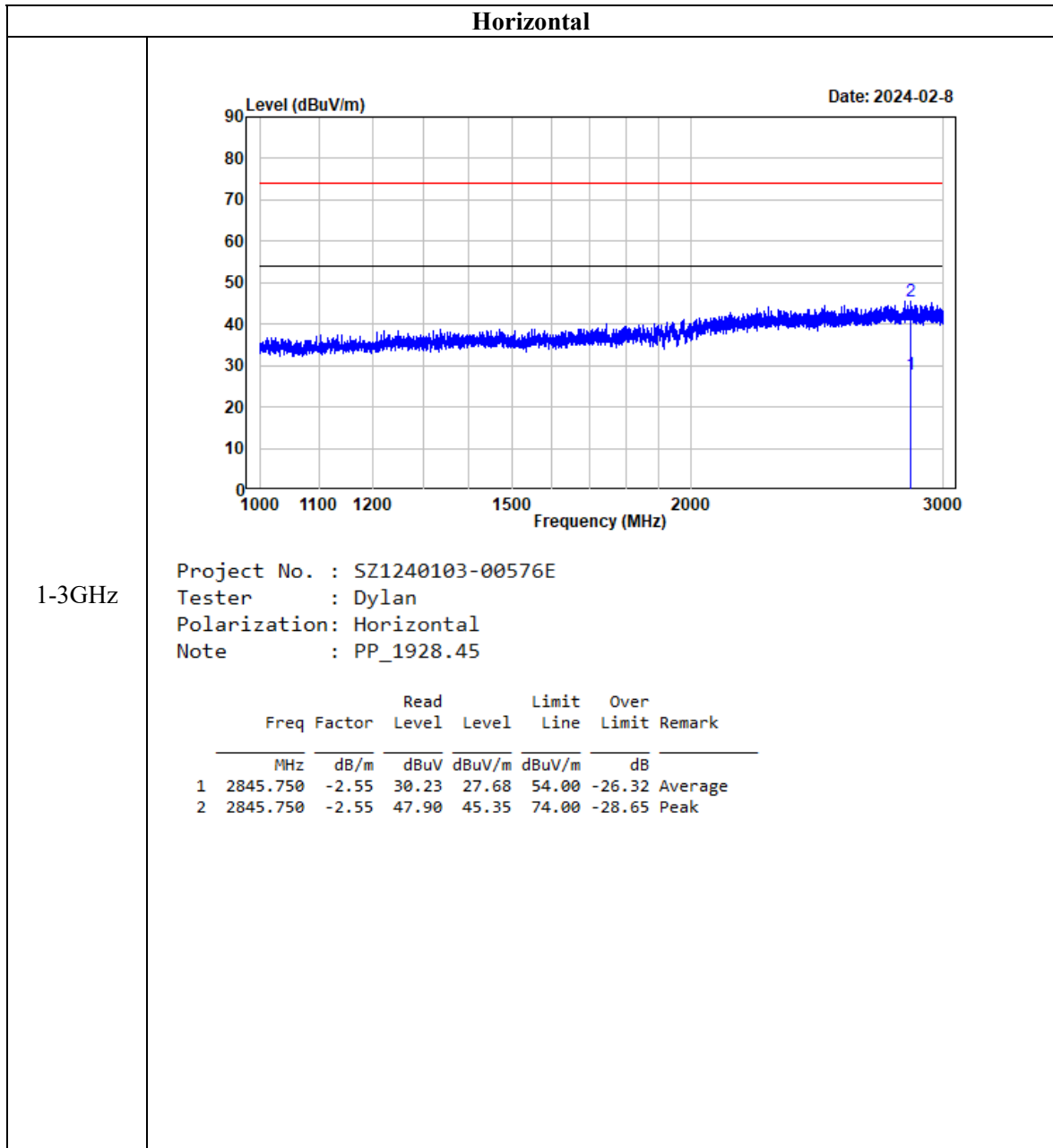

Vertical

1-3GHz

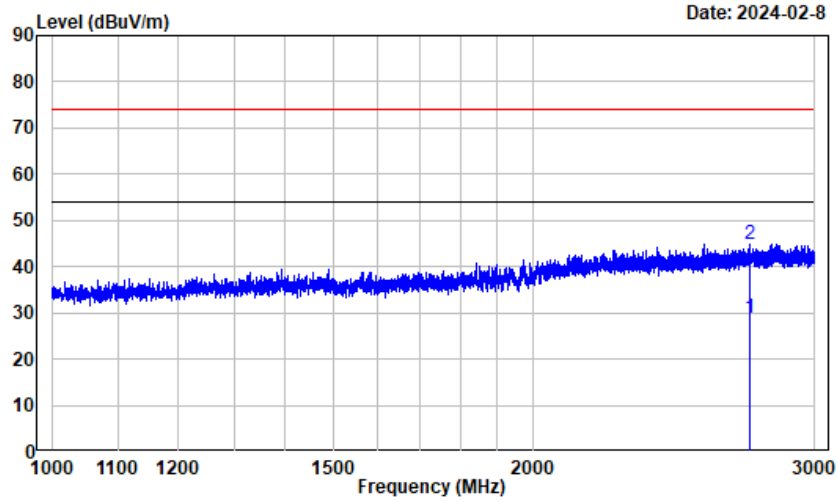

Project No. : SZ1240103-00576E
 Tester : Dylan
 Polarization: Vertical
 Note : PP_1928.45

	Freq	Factor	Read Level	Level	Limit Line	Over Limit	Remark
	MHz	dB/m	dBuV	dBuV/m	dBuV/m	dB	
1	2731.750	-2.76	31.76	29.00	54.00	-25.00	Average
2	2731.750	-2.76	47.75	44.99	74.00	-29.01	Peak

Horizontal

3-18GHz

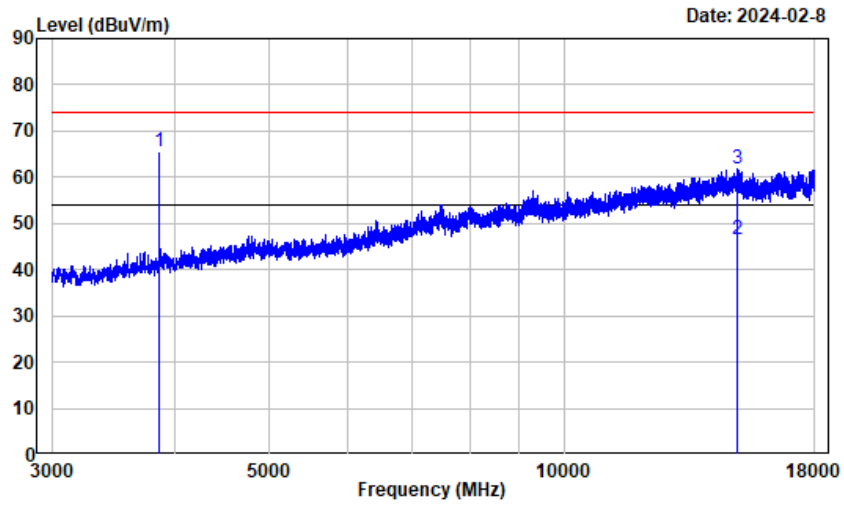

Project No. : SZ1240103-00576E
 Tester : Dylan
 Polarization: Horizontal
 Note : PP_1928.45

	Freq	Factor	Read Level	Level	Limit Line	Over Limit	Remark
	MHz	dB/m	dBuV	dBuV/m	dBuV/m	dB	
1	3856.900	-0.74	66.31	65.57	74.00	-8.43	Peak
2	15003.750	16.30	30.12	46.42	54.00	-7.58	Average
3	15003.750	16.30	45.44	61.74	74.00	-12.26	Peak

Vertical

3-18GHz

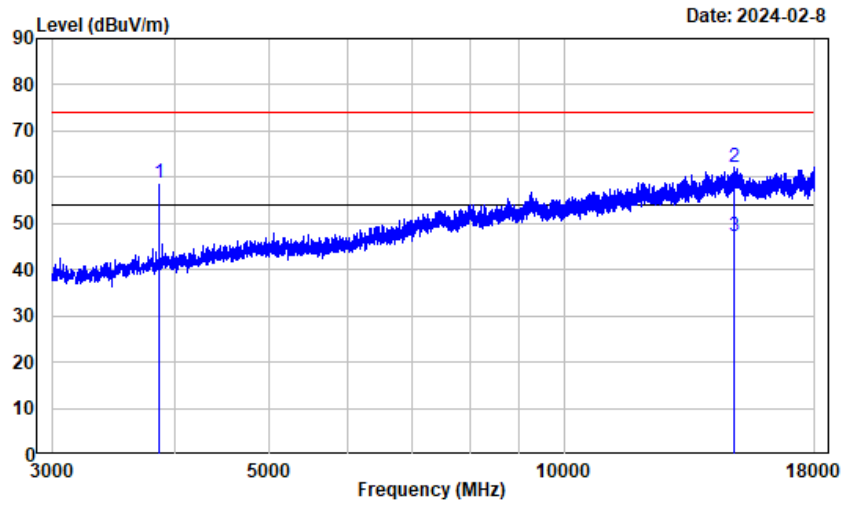

Project No. : SZ1240103-00576E
 Tester : Dylan
 Polarization: Vertical
 Note : PP_1928.45

	Freq	Factor	Read Level	Level	Limit Line	Over Limit	Remark
	MHz	dB/m	dBuV	dBuV/m	dBuV/m	dB	
1	3856.900	-0.74	59.51	58.77	74.00	-15.23	Peak
2	14919.380	16.52	45.59	62.11	74.00	-11.89	Peak
3	14919.380	16.52	30.64	47.16	54.00	-6.84	Average

Horizontal

18-20GHz

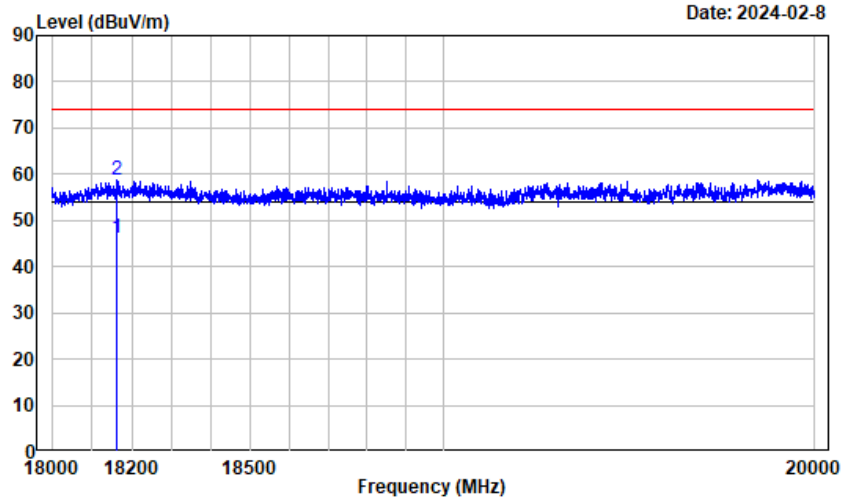

Project No. : SZ1240103-00576E
 Tester : Dylan
 Polarization: Horizontal
 Note : PP_1928.45

	Read	Limit	Over				
Freq	Factor	Level	Level	Line			
MHz	dB/m	dBuV	dBuV/m	dBuV/m			
1	18162.750	13.78	32.33	46.11	54.00	-7.89	Average
2	18162.750	13.78	45.13	58.91	74.00	-15.09	Peak

Vertical

18-20GHz

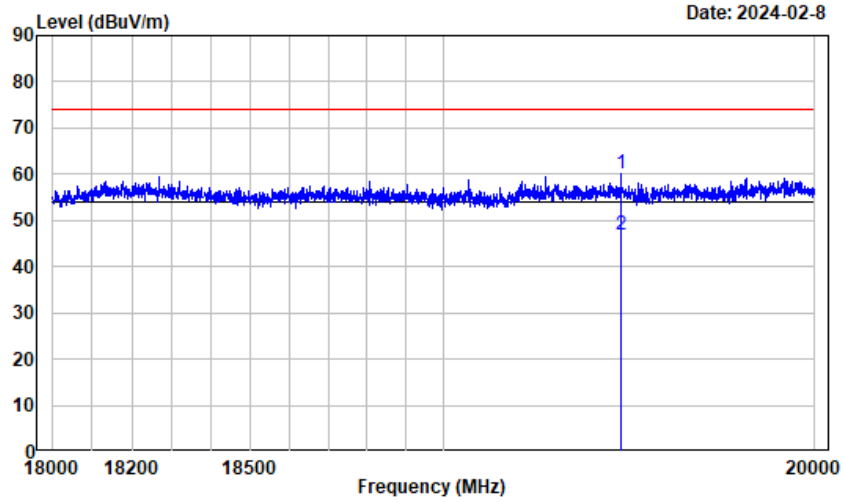

Project No. : SZ1240103-00576E
 Tester : Dylan
 Polarization: Vertical
 Note : PP_1928.45

	Read	Limit	Over				
Freq	Factor	Level	Level	Line			
MHz	dB/m	dBuV	dBuV/m	dBuV/m			
1	19472.630	13.88	46.29	60.17	74.00	-13.83	Peak
2	19472.630	13.88	32.83	46.71	54.00	-7.29	Average

§ 15.323 (f) & RSS-213 §5.3 FREQUENCY STABILITY

Applicable Standard

Per §15.323(f) & ANSI C63.17-2013 Clause 6.2.1, the frequency stability of the carrier frequency of the intentional radiator shall be maintained within ± 10 ppm over 1 hour or the interval between channel access monitoring, whichever is shorter. The frequency stability shall be maintained over a temperature variation of -20°C to $+50^{\circ}\text{C}$ or as declared by the manufacturer at normal supply voltage, and over a variation in the primary supply voltage of 85 percent to 115 percent of the rated supply voltage at a temperature of 20°C . For equipment that is capable only of operating from a battery, the frequency stability tests shall be performed using a new battery without any further requirement to vary supply voltage.

According to RSS-213 Issue 3 (2015-03) § (5.3):
The carrier frequency stability shall be maintained within ± 10 ppm ($\pm 0.001\%$).

According to RSS-Gen Issue5 (2021-02) § (8.11) & ANSI C63.17-2013 Clause 6.2.1:
Transmitter frequency stability for licence-exempt radio apparatus shall be measured in accordance with Section 6.11. For licence-exempt radio apparatus, the frequency stability shall be measured at temperatures of -20°C (-4°F), $+20^{\circ}\text{C}$ ($+68^{\circ}\text{F}$) and $+50^{\circ}\text{C}$ ($+122^{\circ}\text{F}$) instead of at the temperatures specified in Section 6.11.

Test Procedure

This procedure should be carried out for each of the following test cases:

Temperature	Supply Voltage
20°C	85-115% or new batteries
-20°C	Normal
$+50^{\circ}\text{C}$	Normal

During test, the equipment shall be placed in the boxes and set the temperature to the specified requirement until the thermal balance has been reached.

Using the mean carrier frequency at 20°C and at nominal supply voltage as the reference, the mean carrier frequency shall be maintained within ± 10 ppm at the two extreme temperatures (or as declared by the manufacturer) and at normal temperature (typically 20°C) at the two extreme supply voltages. This test does not apply to a EUT that is capable only of operating from a battery.

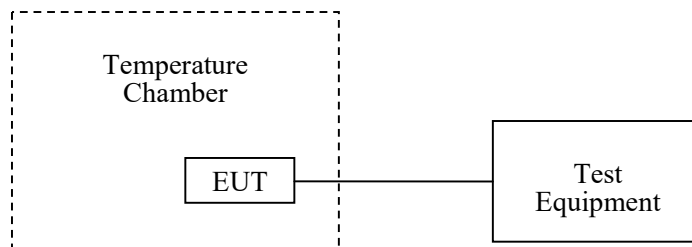

Test Data

Environmental Conditions

Temperature:	26.5 °C
Relative Humidity:	49 %
ATM Pressure:	101 kPa

The testing was performed by Bruce Lin on 2024-03-25.

Test Result: Compliant

Test mode: Transmitting

Temperature (°C)	Voltage (V _{AC} <input type="checkbox"/> , V _{DC} <input checked="" type="checkbox"/>)	Channel Frequency (MHz)	Measured Frequency Offset (kHz)	Measured Frequency Offset (ppm)	Limit (ppm)
-20	3.7	1924.992	5	2.60	±10
+20	3.7	1924.992	4	2.08	±10
+50	3.7	1924.992	7	3.64	±10

Note: the extreme test condition was declared by applicant.

§ 15.323 (c)(e) § 15.319 (f) & RSS-213 §5.1&§5.2 SPECIFIC REQUIREMENTS FOR UPCS DEVICE

Applicable Standard

FCC§15.323(c)(e) & §15.319(f) Specific Requirements for UPCS device.
ANSI C63.17 2013 §6.2 Frequency and time stability and §7.Monitoring tests and §8.Time and spectrum window access procedure.

According to RSS-213 §5.1&§5.2 type of modulation and access protocol
Equipment certified under this standard shall use digital modulation.
In order to provide equitable access to the radio frequency spectrum, the licence-exempt PCS device must possess an access protocol.

Test Procedure

Measurement method according to ANSI C63.17- 2013

Test configuration as below

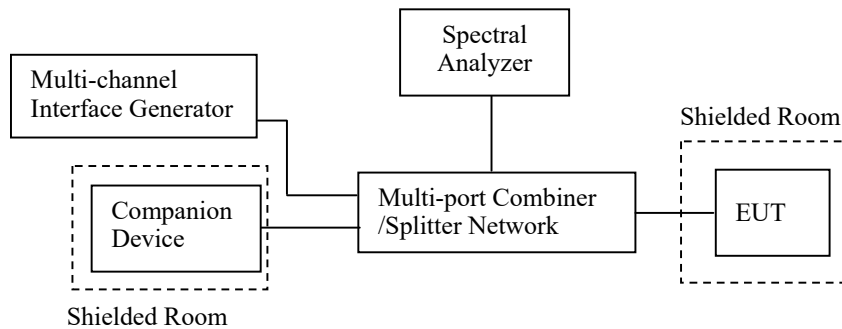

Test Data

Environmental Conditions

Temperature:	26.5 °C
Relative Humidity:	49 %
ATM Pressure:	101 kPa

The testing was performed by Bruce Lin on 2024-03-25.

Test Result: Compliant

Please see the below data

1) Automatic Discontinuation of Transmission

Test result:

The following tests were performed after a connection had been established with Base.

Test condition	Reaction of EUT	Pass/Fail
Adapter removed from EUT	Connection break down	Pass
Battery remove from Handset	Connection break down	Pass

2) Monitoring Time

Test result:

This requirement is covered by the results of Least Interfered Channel (LIC).

Interference (Refer to ANSI C63.17 clause 7.3.3)	Reaction of EUT	Results
a) Apply the interference on f_1 at level $T_L+U_M+20\text{dB}$ and no interference on f_2 . Initiate transmission and verify the transmission only on f_2 . Then terminate it.	EUT transmits on f_2	Pass
b) Apply the interference on f_2 at level $T_L+U_M+20\text{dB}$ and immediately remove all interference from f_1 . The EUT should immediately attempt transmission on f_1 (but at least 20 ms after the interference on f_2 is applied), verify the transmission only on f_1 .	EUT transmission f_1	Pass

3) Lower Monitoring Threshold

Test result:

Not applicable because the EUT has more 40 defined duplex system access channels and meet the provision of the Least Interfered Channel (LIC).

4) Maximum Transmit Period

Test result:

Repetition of Access Criteria	Measured Maximum Transmission Time (Second)	Limit (Second)	Results
First	20023	28,800	Pass
Second	23166	28,800	Pass

5) System Acknowledgement

Test result:

Test	Time taken (second)	Limit (second)	Result
Initial Connection acknowledgement	0.3	1	Pass
Change of access criteria for control information	N/A	30	N/A
Transmission cease time after loss of acknowledgement	14	30	Pass

Note: N/A=Not Applicable

6) Least Interfered Channel (LIC)

Calculation of monitoring threshold limits for isochroous devices:

Lower threshold: $T_L = -174 + 10\log_{10}B + M_L + P_{MAX} - P_{EUT}$ (dBm)

Where: B=Emission bandwidth (Hz)

M_L = dB the threshold may exceed thermal noise (30 for T_L)

P_{MAX} = $5\log_{10}B - 10$ (dBm)

P_{EUT} = Transmitted power (dBm)

Calculated thresholds:

Monitor Threshold	B(MHz)	M_L (dB)	P_{MAX} (dBm)	P_{EUT} (dBm)	Threshold (dBm)
Lower threshold	1.471	30	20.84	19.94	-81.42

Note: The upper threshold is applicable as the EUT utilizes more than 20 duplex system channels

Test result:

1) LIC procedure test:

Interference (Refer to ANSI C63.17 clause 7.3.3)	Reaction of EUT	Results
a) Apply the interference on f_1 at level $T_L + U_M + 7$ dB and the interference on f_2 at level $T_L + U_M$. Initiate transmission and verify the transmission only on f_2 . Repeat 5 times.	EUT transmits on f_2	Pass
b) Apply the interference on f_1 at level $T_L + U_M$ and the interference on f_2 at level $T_L + U_M + 7$ dB. Initiate transmission and verify the transmission only on f_1 . Repeat 5 times.	EUT transmits on f_1	Pass
c) Apply the interference on f_1 at level $T_L + U_M + 1$ dB the interference on f_2 at level $T_L + U_M - 6$ dB. Initiate transmission and verify the transmission only on f_2 . Repeat 5 times.	EUT transmits on f_2	Pass
d) Apply the interference on f_1 at level $T_L + U_M - 6$ dB and the interference on f_2 at level $T_L + U_M + 1$ dB. Initiate transmission and verify the transmission only on f_1 . Repeat 5 times.	EUT transmits on f_1	Pass

2) Selected channel confirmation:

Interference (Refer to ANSI C63.17 clause 7.3.4)	Reaction of EUT	Results
a) Apply the interference on f_1 at level T_U+U_M and no interference on f_2 . Initiate transmission and verify the transmission only on f_2 . Then terminate it.	EUT transmits on f_2	Pass
b) Apply the interference on f_2 at level T_L+U_M and immediately remove all interference from f_1 . The EUT should immediately attempt transmission on f_1 (but at least 20 ms after the interference on f_2 is applied), verify the transmission only on f_1 .	EUT transmission f_1	Pass

7) Random waiting

Note: This is Not Applicable

8) Monitoring Bandwidth and Reaction Time

Test result:

1) Monitoring Bandwidth:

The antenna of the EUT used for monitoring is the same interior antenna that used for transmission, so the monitoring system bandwidth is equal to the emission bandwidth of the intended transmission

2) Reaction Time Test:

No.	Interference Pulse width (μ s)	Reaction of EUT	Observing time (μ s)	Result
1	50 μ s with level T_L+U_M	No transmission	28.42	Pass
2	35 μ s with level T_L+U_M+6 dB	No transmission	27.69	Pass

9) Monitoring Antenna

Test result:

The antenna of the EUT used for transmission is the same interior antenna that used for monitoring.

10) Monitoring threshold relaxation

Test result:

This requirement is covered by the results of Least Interfered Channel (LIC).

11) Duplex Connections

Test result:

Interference (Refer to ANSI C63.17 § 8.3& § 8.3.2)	Reaction of EUT	Results
a) Only a single carrier f_1 for EUT TDMA systems and on f_1 and f_2 and corresponding duplex carriers for FDMA systems.	EUT can transmit	Pass
b) All Tx windows with level TL+UM except one & Rx windows with level TL+UM+7dB except one, which are not the duplex mate.	Connected on the target Rx window and its duplex mate.	Pass
c) All Tx windows with level TL+UM+7dB except one & Rx windows with level TL+UM except one, which are not duplex mate.	Connected on the target Tx window and its duplex mate.	Pass
d) All Tx & Rx windows with level TU+UM, except one for Tx window & one for Rx window, which are not duplex mate.	No connection possible	Pass

12) Alternative monitoring interval

Test result:

Interference (Refer to ANSI C63.17 § 8.4)	Reaction of EUT	Results
a) Only a single carrier f_1 for EUT TDMA systems and on f_1 and f_2 and corresponding duplex carriers for FDMA systems.	EUT can transmit	Pass
b) Apply interference with same parameters as EUT transmissions on all Tx windows with level TL+UM on the enabled carrier(s) and no interference on the Rx windows on the enabled carriers.	No connection is established	Pass

IC:

Not appropriate, as the system always monitor both the transmit and receive time/spectrum windows, it is not a co-located device.

13) Fair Access

Test result:

The manufacturer declares that this device does not use any mechanisms as provided by FCC §15.323(c)(10) or (11) & IC RSS-213 5.2(10) and (11) to extend the range of spectrum occupied over space or time for the purpose of denying fair access to spectrum to other device.

14) Frame Repetition Stability Frame Period and Jitter

Test result:

Frame Period and Jitter:

Max. pos. Jitter (µs)	Max. neg. Jitter (µs)	Frame period (ms)	Limit	
			Frame Period (ms)	Jitter (µs)
0.42	-0.26	10.25	20 or 10/X	25

Note: X is a positive whole number.

EUT PHOTOGRAPHS

Please refer to the attachment SZ1240103-00576E-RF-PP External photo and SZ1240103-00576E-RF-PP Internal photo.

TEST SETUP PHOTOGRAPHS

Please refer to the attachment SZ1240103-00576E-RF-PP Test Setup photo.

******* END OF REPORT *******