

FCC - TEST REPORT

Report Number : **68.950.24.0393.01** Date of Issue: 2024-04-26

Model : ASTRUM MX PRO, HT320, HT430, HT250, HT100

Product Type : Bluetooth Headset

Applicant : ASTRUM WORLD INC

Address : 3580 WILSHIRE BLVD, 1410 LOS ANGELES, CA 90010
United States

Manufacturer : SHENZHEN AKAUDIO CO., LIMITED

Address : 7F, Bldg A (#2), 1st Shuichanjingwan Industrial Area,
Nanchang Village, Gushu, Bao'an Dist., Shenzhen, China

Test Result : **Positive** **Negative**

Total pages including Appendices : 54

Any use for advertising purposes must be granted in writing. This technical report may only be quoted in full. This report is the result of a single examination of the object in question and is not generally applicable evaluation of the quality of other products in regular production. For further details, please see testing and certification regulation, chapter A-3.4.



1 Table of Contents

- 1 Table of Contents2
- 2 Details about the Test Laboratory3
- 3 Description of the Equipment Under Test4
- 4 Summary of Test Standards5
- 5 Summary of Test Results6
- 6 General Remarks7
- 7 Test Setups8
- 8 Systems Test Configuration9
- 9 Technical Requirement 10
 - 9.1 Conducted Peak Output Power..... 10
 - 9.2 20 dB Bandwidth 15
 - 9.3 Carrier Frequency Separation 20
 - 9.4 Number of Hopping Frequencies 22
 - 9.5 Dwell Time..... 24
 - 9.6 Spurious RF Conducted Emissions 32
 - 9.7 Band Edge Testing..... 40
 - 9.8 Spurious Radiated Emissions for Transmitter..... 46
- 10 Test Equipment List..... 53
- 11 System Measurement Uncertainty 54

2 Details about the Test Laboratory

Details about the Test Laboratory

Test Site 1

Company name: TÜV SÜD Certification and Testing (China) Co., Ltd. Shenzhen Branch
Building 12 & 13, Zhiheng Wisdomland Business Park, Guankou Erlu, Nantou,
Nanshan District
Shenzhen 518052
P.R. China

Telephone: 86 755 8828 6998

Fax: 86 755 828 5299

FCC Registration 514049

No.:

FCC Designation CN5009
Number:

3 Description of the Equipment Under Test

Product:	Bluetooth Headset
Model No.:	ASTRUM MX PRO, HT320, HT430, HT250, HT100
Model difference.:	All models have the same technical construction including circuit diagram, PCB layout, components and component layout. Only the model's name and outlook/color are different. So the main test model is ASTRUM MX PRO.
Brand name:	ASTRUM
FCC ID:	2BFJ5-ASTRUMMXPRO
Options and accessories:	N/A
Battery information:	Rechargeable Li-ion Battery Model:ST 602540 Rated:3.7VDC 2.22Wh
Rating:	3.7VDC rechargeable Li-ion battery or supplied by external USB Input (5VDC)
RF Transmission Frequency:	2402MHz-2480MHz
No. of Operated Channel:	79
Modulation:	GFSK, $\pi/4$ -DQPSK, 8DPSK
Antenna Type:	FPC Antenna
Antenna	Gain: 1.0dBi
Description of the EUT:	The Equipment Under Test (EUT) is a Bluetooth Headset which support Bluetooth function operated at 2.4GHz. Only Bluetooth (BR+EDR) included in this report.

NOTE: The above EUT's information is declared by manufacturer. Please refer to the specifications or user's manual for more detailed description.

4 Summary of Test Standards

Test Standards	
FCC Part 15 Subpart C 10-1-2023 Edition	PART 15 - RADIO FREQUENCY DEVICES Subpart C - Intentional Radiators

All the test methods were according to KDB 558074 D01 15.247 Meas Guidance v05r02 Measurement Guidance and ANSI C63.10-2020.

5 Summary of Test Results

Technical Requirements			
FCC Part 15 Subpart C			
Test Condition		Test Site	Test Result
§15.207	Conducted emission AC power port*	N/A	N/A
§15.247(b)(1)	Conducted peak output power	Site 1	Pass
§15.247(a)(1)	20dB bandwidth	Site 1	Pass
§15.247(a)(1)	Carrier channel frequency separation	Site 1	Pass
§15.247(a)(1)(iii)	Number of hopping frequencies	Site 1	Pass
§15.247(a)(1)(iii)	Dwell Time - Average Time of Occupancy	Site 1	Pass
§15.247(d)	Spurious RF conducted emissions	Site 1	Pass
§15.247(d)	Band edge	Site 1	Pass
§15.247(d) & §15.209 &§15.205	Spurious radiated emissions for transmitter	Site 1	Pass
§15.203	Antenna requirement	See note 2	Pass

Note: * The EUT cannot charging and Transmitting at the same time.

Note 1: N/A=Not Applicable.

Note 2: The EUT uses a FPC antenna, which gain is 1.0dBi. In accordance to §15.203, it is considered sufficiently to comply with the provisions of this section.

6 General Remarks

Remarks

This submittal(s) (test report) is intended for FCC ID: 2BFJ5-ASTRUMMXPRO, complies with Section 15.209, 15.247 of the FCC Part 15, Subpart C rules.

SUMMARY:

All tests according to the regulations cited on page 5 were

- Performed

- **Not** Performed

The Equipment Under Test

- **Fulfills** the general approval requirements.

- **Does not** fulfill the general approval requirements.

Sample Received Date: 2024-04-15

Testing Start Date: 2024-04-15

Testing End Date: 2024-04-25

- TÜV SÜD Certification and Testing (China) Co., Ltd. Shenzhen Branch -

Reviewed by:

Prepared by:

Tested by:

John Zhi
Section Manager



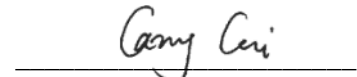

Sanvin Zheng
Project Engineer

Carry Cai
Test Engineer

7 Test Setups

7.1 Radiated test setups

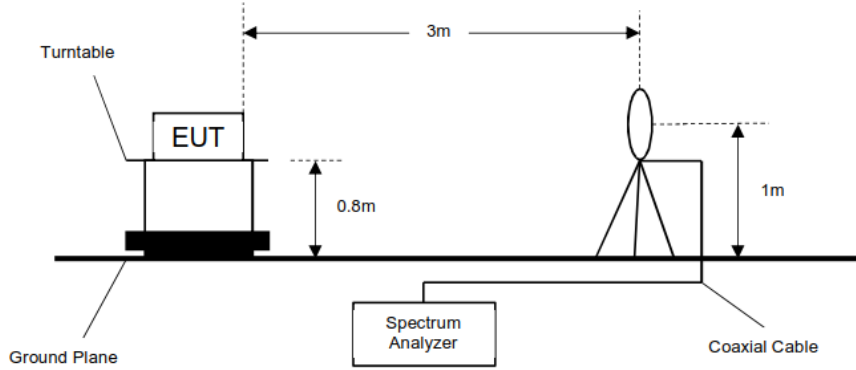
9KHz - 30MHz



30MHz - 1GHz

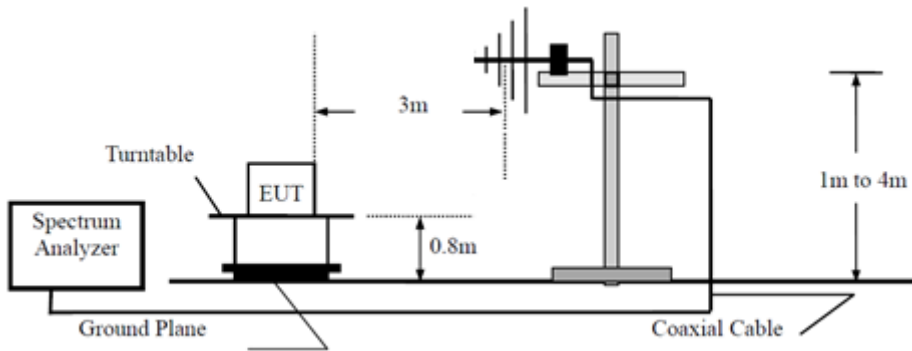

Above 1GHz

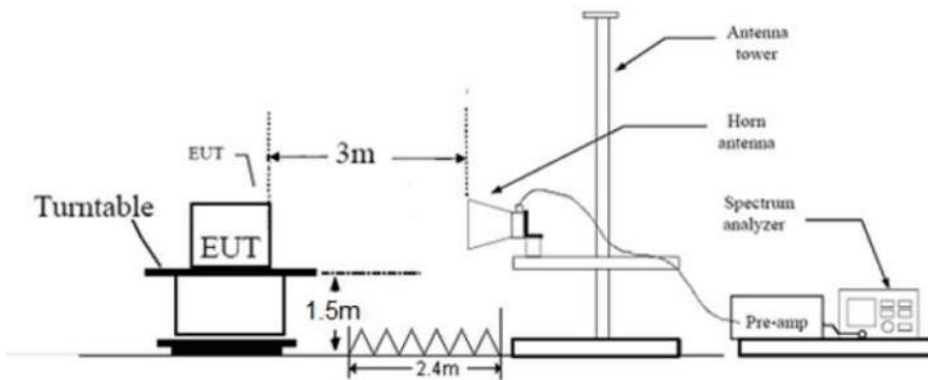

7.3 Conducted RF test setups

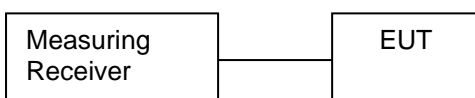

8 Systems Test Configuration

Auxiliary Equipment Used during Test:

Description	Manufacturer	Model NO.	S/N
Notebook	LENOVO	X220	---

Cables Used During Test:

Cable	Length	Shielded/unshielded	With / without ferrite
---	---	---	---

Test software information:

Test Software Version	Blue Test3.exe	
Modulation	Setting TX Power	Packet Type
GFSK	-4	PRBS9
$\pi/4$ -DQPSK	-4	PRBS9
8DPSK	-4	PRBS9

The system was configured to hopping mode and non-hopping mode.

Hopping mode: typical working mode (normal hopping status)

Non-hopping mode: The system was configured to operate at a signal channel transmitting. The test software allows the configuration and operation at the worst-case duty and the highest transmit power.

9 Technical Requirement

9.1 Conducted Peak Output Power

Test Method

1. The RF output of EUT was connected to the spectrum analyzer by RF cable. The path loss was compensated to the results for each measurement.
2. Set to the maximum power setting and enable the EUT transmit continuously.
3. Use the following test receiver settings:
Span = approximately 5 times the 20dB bandwidth, centered on a hopping channel
RBW > the 20dB bandwidth of the emission being measured, VBW ≥ RBW,
Sweep = auto, Detector function = peak, Trace = max hold
4. Allow the trace to stabilize. Use the marker-to-peak function to set the marker to the peak of the emission. The indicated level is the peak output power and record the results in the test report.
5. Repeat above procedures until all frequencies measured were complete.

Limits

According to §15.247 (b) (1), conducted peak output power limit as below:

Frequency Range MHz	Limit W	Limit dBm
2400-2483.5	≤1	≤30

Conducted Peak Output Power

Mode	TX Type	Frequency (MHz)	Packet Type	Maximum Peak Conducted Output Power (dBm)		Verdict
				ANT1	Limit	
GFSK	SISO	2402	DH5	-1.59	<=30	Pass
		2441	DH5	0.41	<=30	Pass
		2480	DH5	0.25	<=30	Pass
Pi/4DQPSK	SISO	2402	2DH5	-5.22	<=30	Pass
		2441	2DH5	-3.47	<=30	Pass
		2480	2DH5	-3.55	<=30	Pass
8DPSK	SISO	2402	3DH5	-4.47	<=30	Pass
		2441	3DH5	-2.76	<=30	Pass
		2480	3DH5	-2.76	<=30	Pass

GFSK_DH5_LCH_2402MHz_Ant1_NTNV

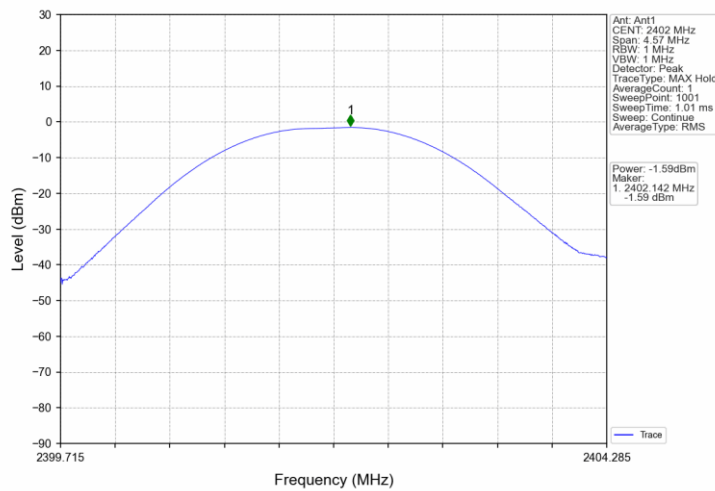

GFSK_DH5_MCH_2441MHz_Ant1_NTNV

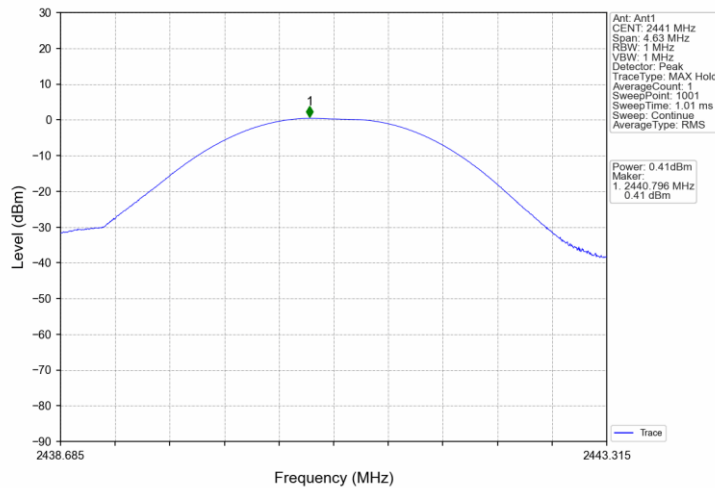

GFSK_DH5_HCH_2480MHz_Ant1_NTNV

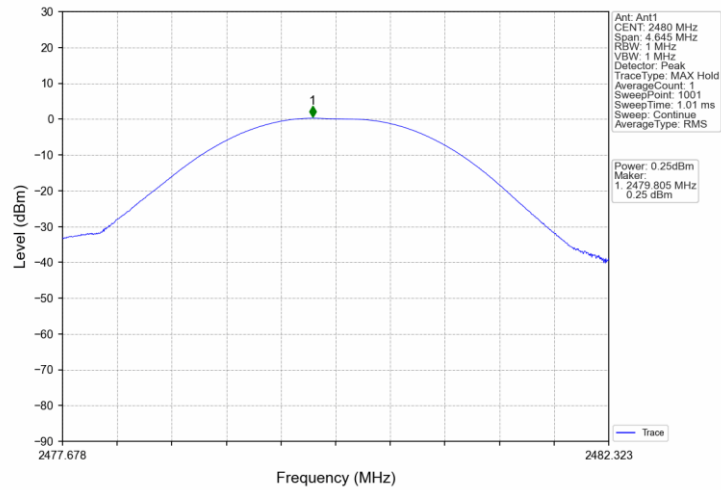

Pi/4DQPSK_2DH5_LCH_2402MHz_Ant1_NTNV

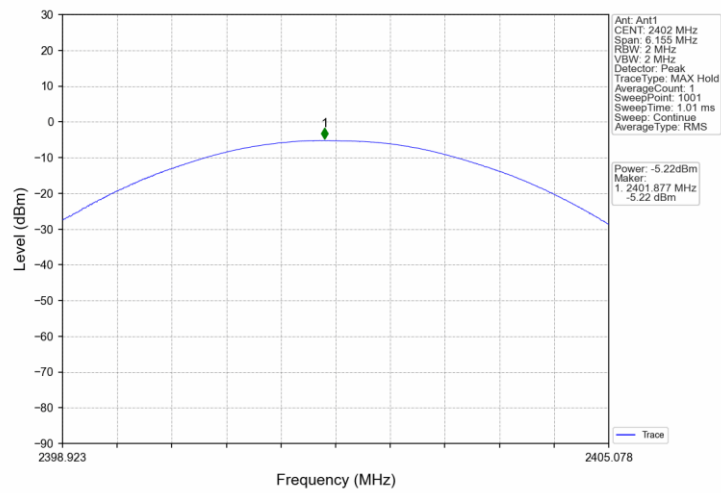

Pi/4DQPSK_2DH5_MCH_2441MHz_Ant1_NTNV

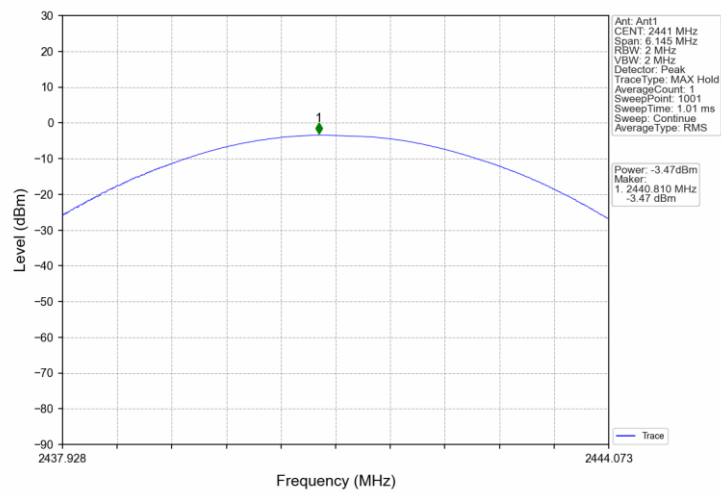

Pi/4DQPSK_2DH5_HCH_2480MHz_Ant1_NTNV

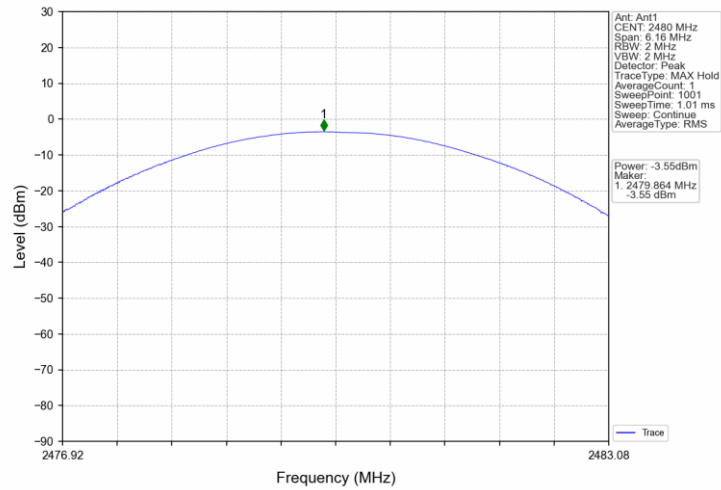

8DPSK_3DH5_LCH_2402MHz_Ant1_NTNV

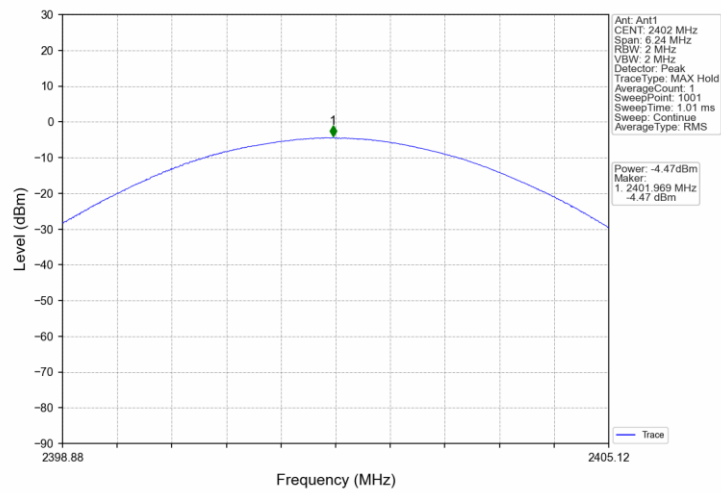

8DPSK_3DH5_MCH_2441MHz_Ant1_NTNV

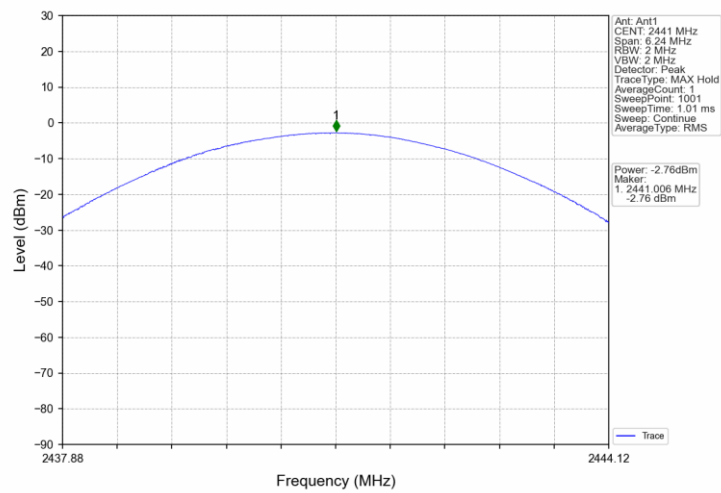

8DPSK_3DH5_HCH_2480MHz_Ant1_NTNV

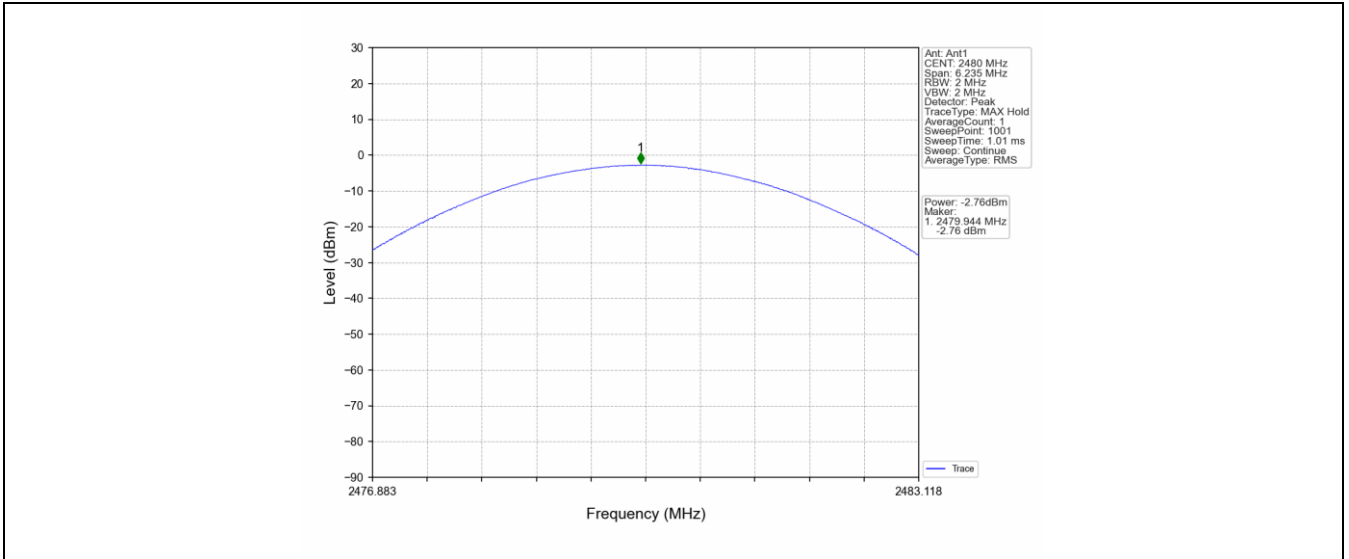

9.2 20 dB Bandwidth

Test Method

1. The RF output of EUT was connected to the spectrum analyzer by RF cable. The path loss was compensated to the results for each measurement.
2. Set to the maximum power setting and enable the EUT transmit continuously.
3. Use the following test receiver settings:
Span = approximately 2 to 3 times the 20 dB bandwidth, centered on a hopping channel
RBW \geq 1% to 5% of the 20 dB bandwidth/99% OBW, VBW \geq 3RBW,
Sweep = auto, Detector function = peak, Trace = max hold
4. Allow the trace to stabilize. Use the marker-to-peak function to set the marker to the peak of the emission. Measure the frequency difference of two frequencies that were attenuated 20 dB from the reference level. Record the frequency difference as the emission bandwidth. Record the results.
5. Repeat above procedures until all frequencies measured were complete.

Limit

According to §15.247(a)(1), 20 dB Bandwidth limit as below:

Limit [kHz]

N/A

20 dB bandwidth

Test result

Mode	TX Type	Frequency (MHz)	Packet Type	ANT	20dB Bandwidth (MHz)		Verdict
					Result	Limit	
GFSK	SISO	2402	DH5	1	0.914	/	Pass
		2441	DH5	1	0.926	/	Pass
		2480	DH5	1	0.929	/	Pass
Pi/4DQPSK	SISO	2402	2DH5	1	1.231	/	Pass
		2441	2DH5	1	1.229	/	Pass
		2480	2DH5	1	1.232	/	Pass
8DPSK	SISO	2402	3DH5	1	1.248	/	Pass
		2441	3DH5	1	1.248	/	Pass
		2480	3DH5	1	1.247	/	Pass

GFSK_DH5_LCH_2402MHz_Ant1_NTNV

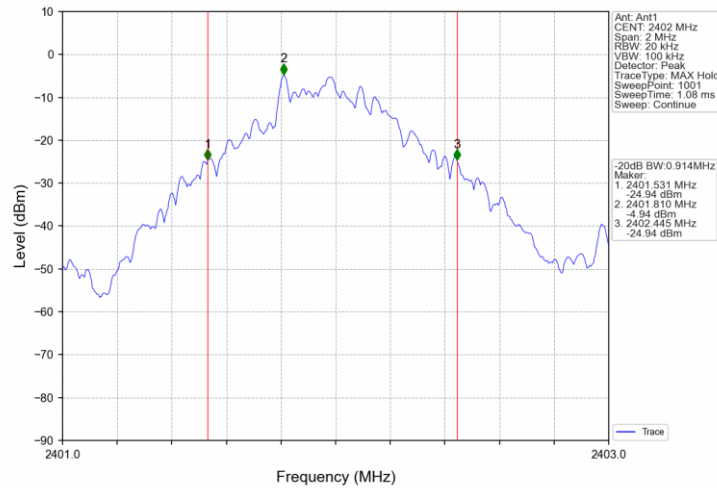

GFSK_DH5_MCH_2441MHz_Ant1_NTNV

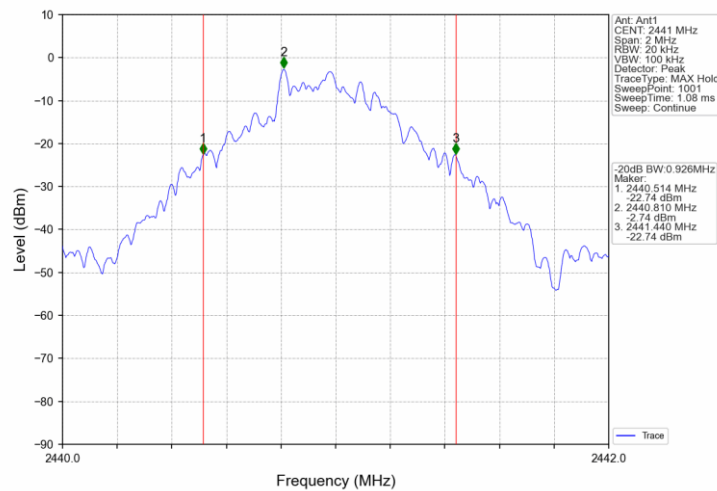

GFSK_DH5_HCH_2480MHz_Ant1_NTNV

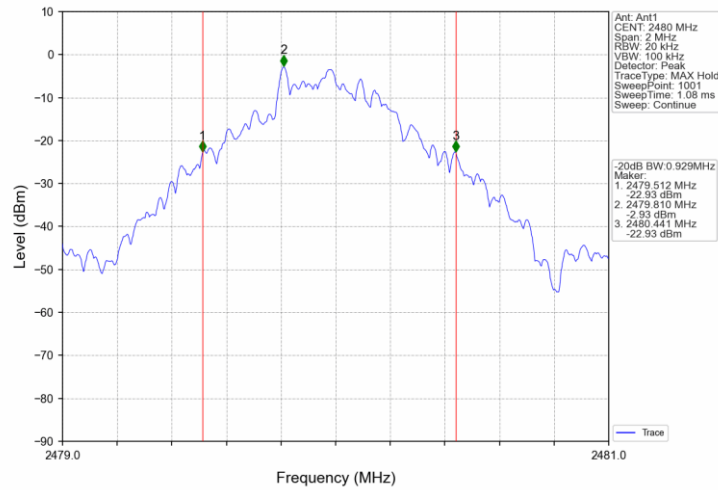

Pi/4DQPSK_2DH5_LCH_2402MHz_Ant1_NTNV

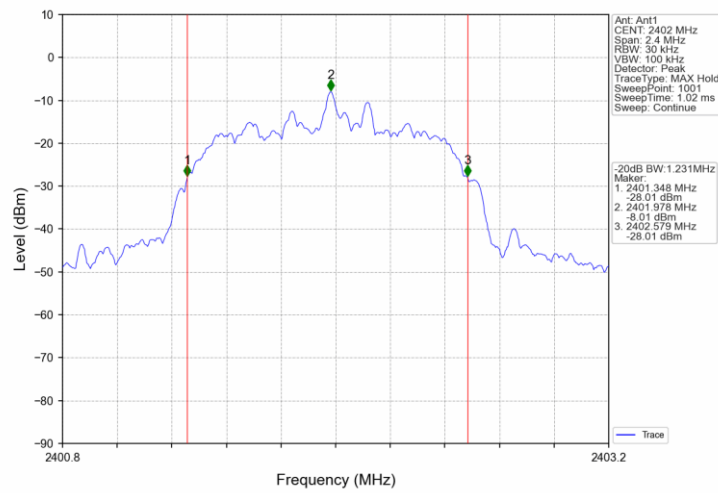

Pi/4DQPSK_2DH5_MCH_2441MHz_Ant1_NTNV

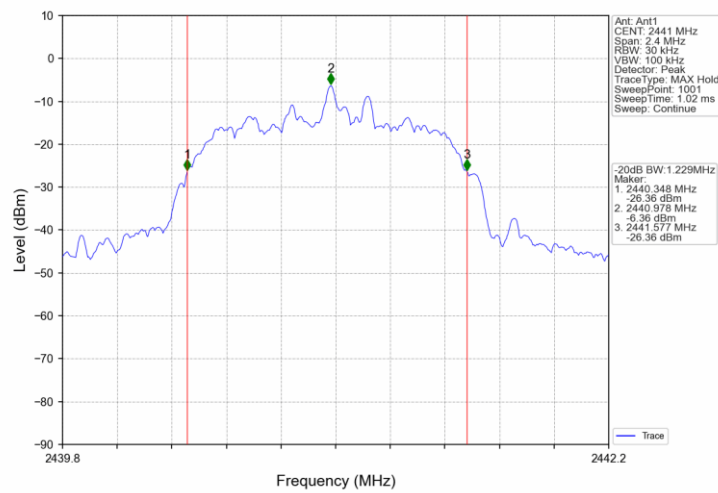

Pi/4DQPSK_2DH5_HCH_2480MHz_Ant1_NTNV

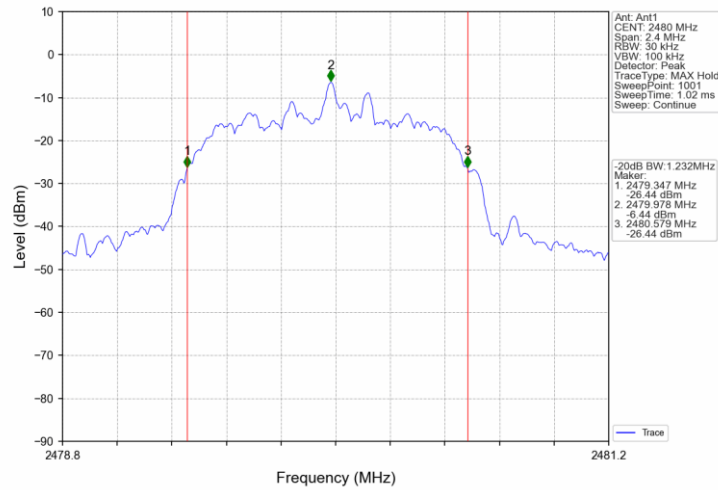

8DPSK_3DH5_LCH_2402MHz_Ant1_NTNV

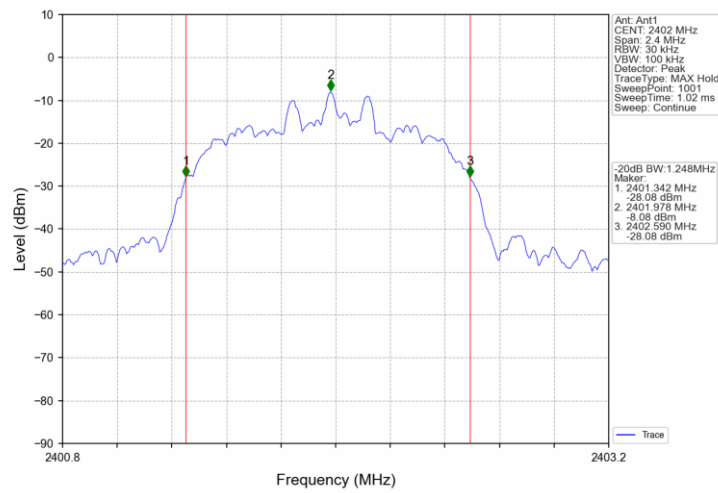

8DPSK_3DH5_MCH_2441MHz_Ant1_NTNV

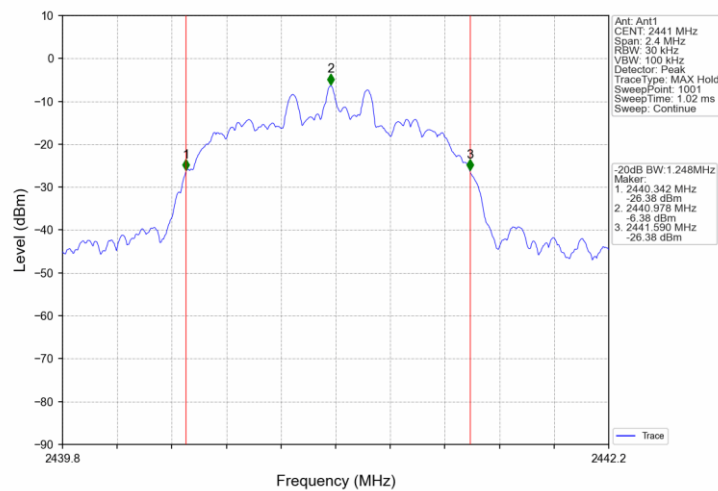

8DPSK_3DH5_HCH_2480MHz_Ant1_NTNV

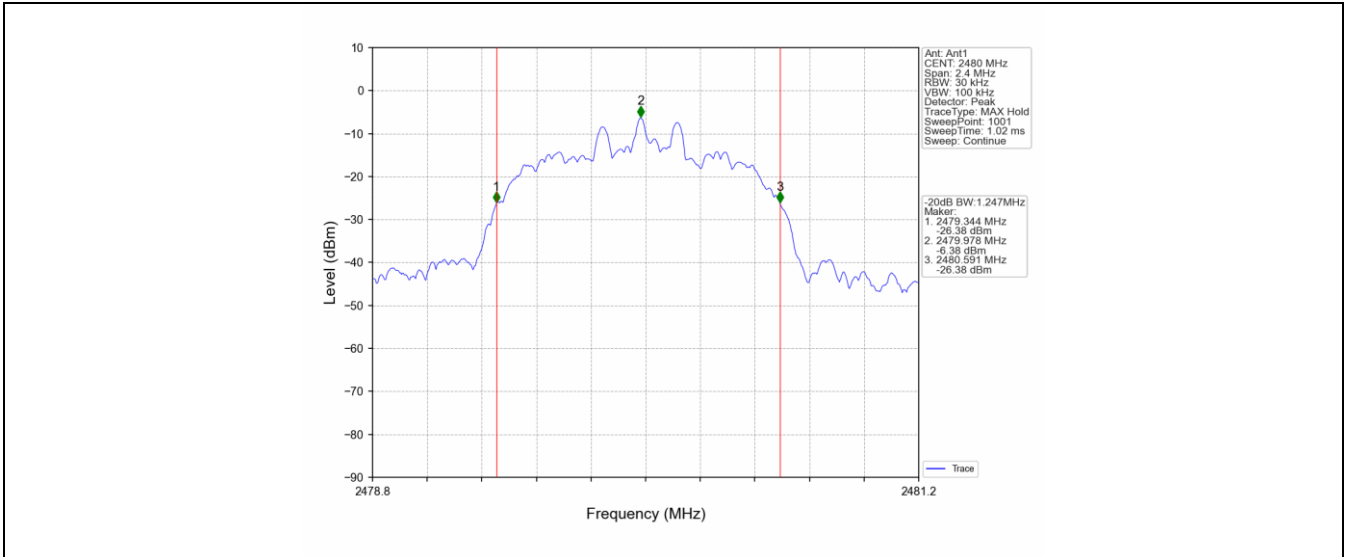

9.3 Carrier Frequency Separation

Test Method

1. The RF output of EUT was connected to the spectrum analyzer by RF cable. The path loss was compensated to the results for each measurement.
2. Set to the maximum power setting and enable the EUT transmit to hopping mode.
3. Use the following spectrum analyzer settings:
Span = wide enough to capture the peaks of two adjacent channels, RBW: Start with the RBW set to approximately 30% of the channel spacing; adjust as necessary to best identify the center of each individual channel. VBW ≥ RBW, Sweep = auto, Detector function = peak.
4. By using the Max-Hold function record the separation of two adjacent channels.
5. Measure the frequency difference of these two adjacent channels by spectrum analyzer marker function. Record the results.
6. Repeat above procedures until all frequencies measured were complete.

Limit

According to §15.247(a)(1), Carrier Frequency Separation limit as below:

$$\text{Limit kHz} \geq 25\text{kHz or } 2/3 \text{ of the } 20 \text{ dB bandwidth which is greater}$$

Test result: The measurement was performed with the typical configuration (normal hopping status).

Ant1							
Mode	TX Type	Frequency (MHz)	Packet Type	Channel Separation (MHz)	20dB Bandwidth (MHz)	Limit (MHz)	Verdict
GFSK	SISO	HOPP	DH5	1.002	0.929	≥0.620	Pass
Pi/4DQPSK	SISO	HOPP	2DH5	1.001	1.232	≥0.822	Pass
8DPSK	SISO	HOPP	3DH5	0.998	1.248	≥0.832	Pass

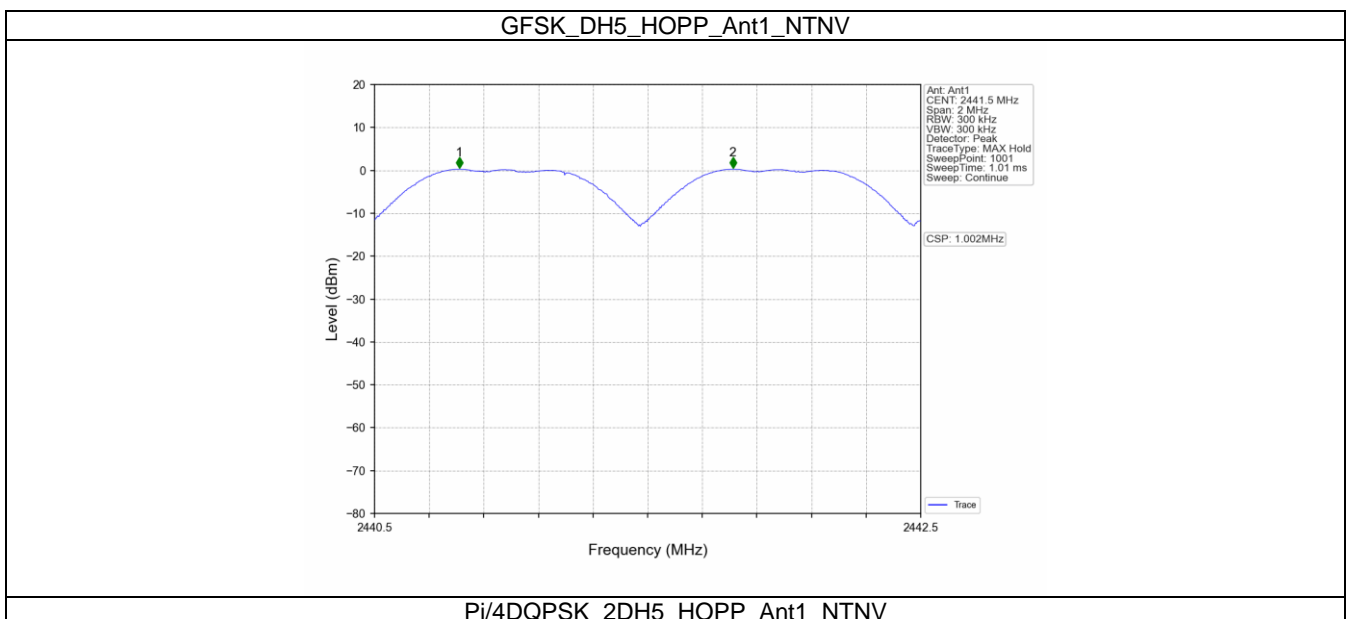

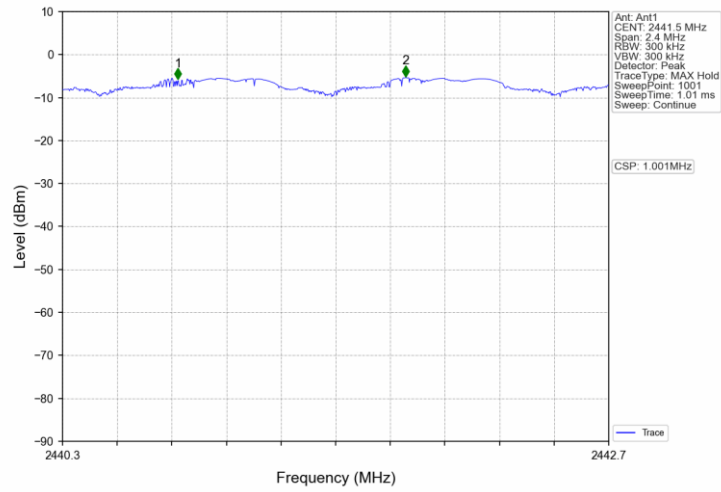

8DPSK_3DH5_HOPP_Ant1_NTNV

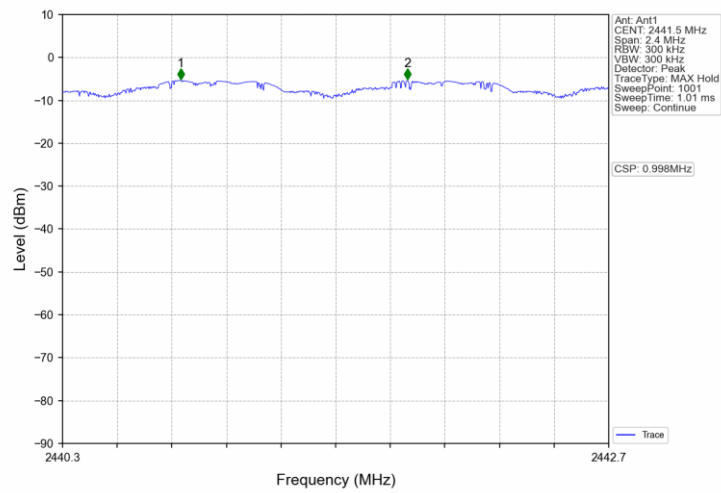

9.4 Number of Hopping Frequencies

Test Method

1. The RF output of EUT was connected to the spectrum analyzer by RF cable. The path loss was compensated to the results for each measurement.
2. Set to the maximum power setting and enable the EUT transmit to hopping mode.
3. Use the following spectrum analyzer settings:
Span = the frequency band of operation, RBW: To identify clearly the individual channels, set the RBW to less than 30% of the channel spacing or the 20 dB bandwidth, whichever is smaller, VBW ≥ RBW, Sweep = auto, Detector function = peak, Trace=Max hold.
4. Allow the trace to stabilize. It may prove necessary to break the span up to sections, in order to clearly show all of the hopping frequencies. The limit is specified in one of the subparagraphs of this Section. Submit this plot(s).

Limit

According to §15.247(a)(1)(iii), Number of Hopping Frequencies limit as below:

$$\frac{\text{Limit number}}{\geq 15}$$

Mode	TX Type	Frequency (MHz)	Packet Type	Num of Hopping Frequencies		Verdict
				ANT1	Limit	
GFSK	SISO	HOPP	DH5	79	≥15	Pass
Pi/4DQPSK	SISO	HOPP	2DH5	79	≥15	Pass
8DPSK	SISO	HOPP	3DH5	79	≥15	Pass

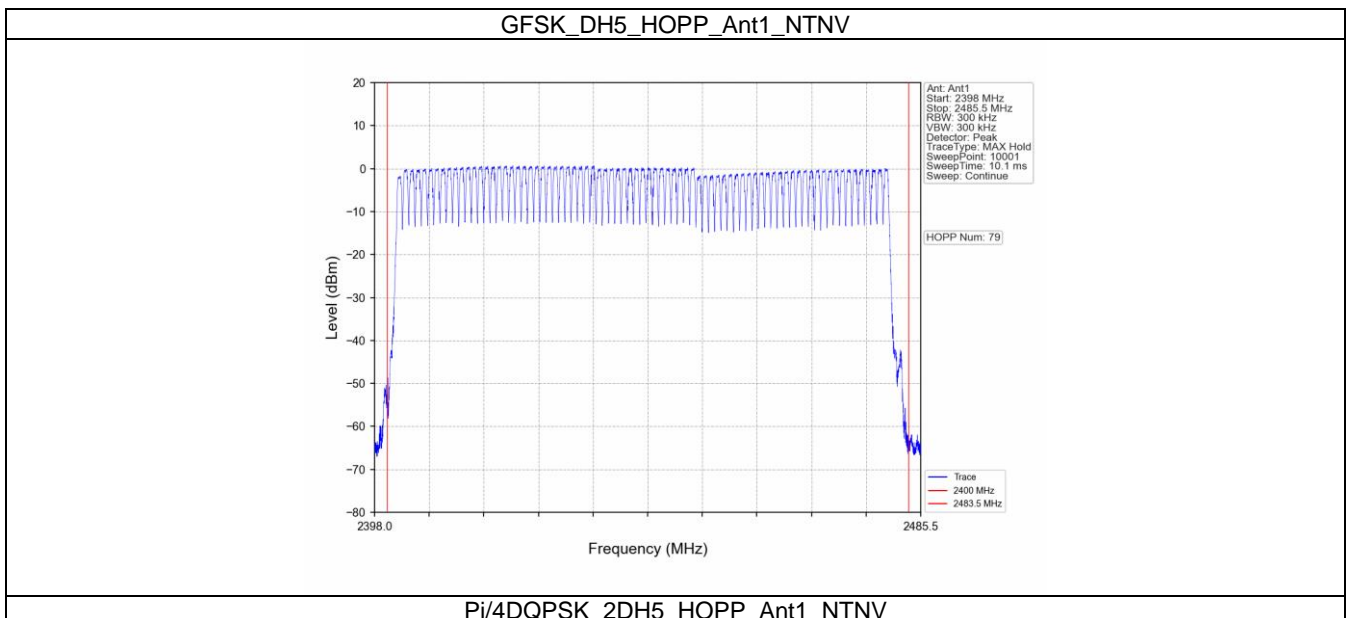

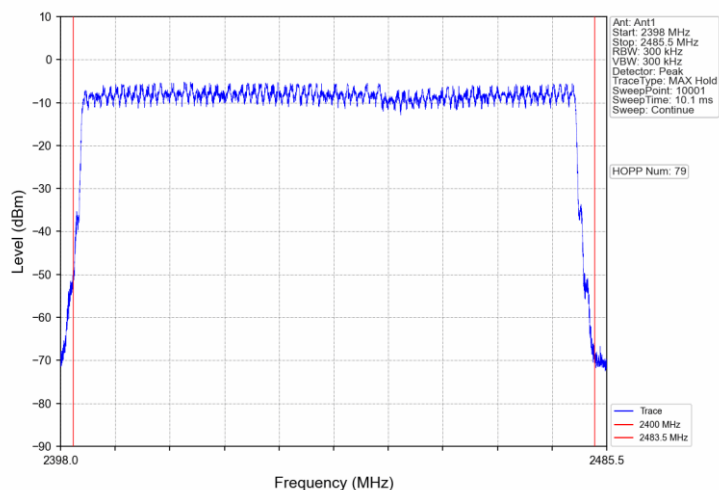

8DPSK_3DH5_HOPP_Ant1_NTNV

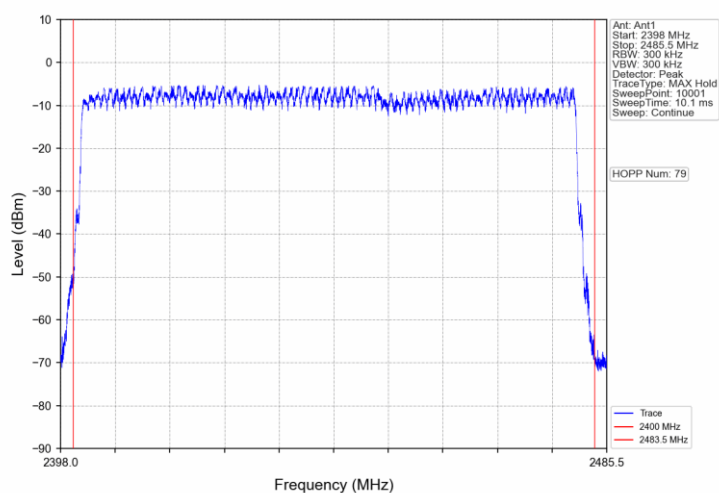

9.5 Dwell Time

Test Method

1. The RF output of EUT was connected to the spectrum analyzer by RF cable. The path loss was compensated to the results for each measurement.
2. Set to the maximum power setting and enable the EUT transmit to hopping mode.
3. Span: Zero span, centered on a hopping channel.
4. RBW shall be \leq channel spacing and where possible RBW should be set $\gg 1 / T$, where T is the expected dwell time per channel.
5. Sweep: As necessary to capture the entire dwell time per hopping channel; where possible use a video trigger and trigger delay so that the transmitted signal starts a little to the right of the start of the plot. The trigger level might need slight adjustment to prevent triggering when the system hops on an adjacent channel; a second plot might be needed with a longer sweep time to show two successive hops on a channel.
6. Detector function: Peak.
7. Trace: Max hold. Use the marker-delta function to determine the transmit time per hop. If this value varies with different modes of operation (data rate, modulation format, number of hopping channels, etc.), then repeat this test for each variation in transmit time.

Limit

According to §15.247(a)(1)(iii), Dwell Time limit as below:

The average time of occupancy on any frequency shall not be greater than 0.4 seconds within a period of 0.4 seconds multiplied by the number of hopping channels employed.

Dwell Time

Dwell time

The maximum dwell time shall be 0.4 s.

According to the Bluetooth Core Specification,

The duration for dwell time calculation: $0.4 \text{ [s]} * \text{hopping number} = 0.4 \text{ [s]} * 79 \text{ [ch]} = 31.6 \text{ [s]}$

The Dwell Time = Burst Width * Total Hops.

Ant1									
Mode	TX Type	Frequency (MHz)	Packet Type	Duration of Single Pulse (ms)	Observation Period (s)	Num of Pulse in Observation Period	Dwell Time (ms)	Limit (ms)	Verdict
GFSK	SISO	HOPP	DH1	0.394	31.600	320	126.080	<=400	Pass
			DH3	1.650	31.600	160	264.000	<=400	Pass
			DH5	0.394	31.600	320	126.080	<=400	Pass
Pi/4DQPSK	SISO	HOPP	2DH1	0.406	31.600	320	129.920	<=400	Pass
			2DH3	1.658	31.600	160	265.280	<=400	Pass
			2DH5	2.914	31.600	106	308.884	<=400	Pass
8DPSK	SISO	HOPP	3DH1	0.414	31.600	320	132.480	<=400	Pass
			3DH3	1.664	31.600	160	266.240	<=400	Pass
			3DH5	2.906	31.600	107	310.942	<=400	Pass

GFSK_DH1_HOPP_Ant1_NTNV

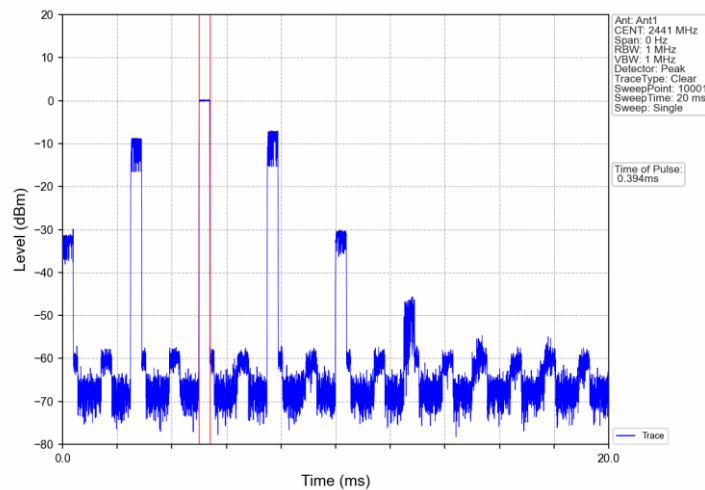

GFSK_DH1_HOPP_Ant1_NTNV

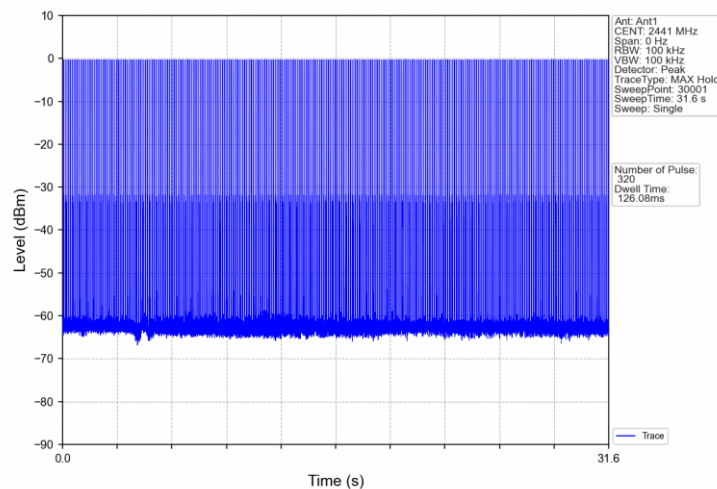

GFSK_DH3_HOPP_Ant1_NTNV

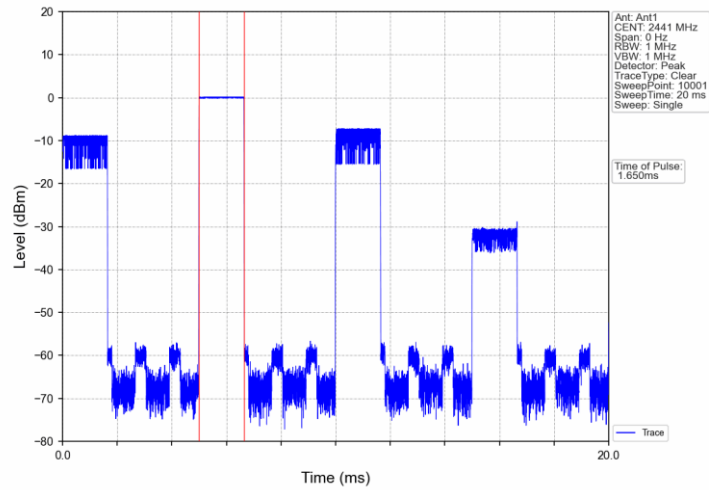

GFSK_DH3_HOPP_Ant1_NTNV

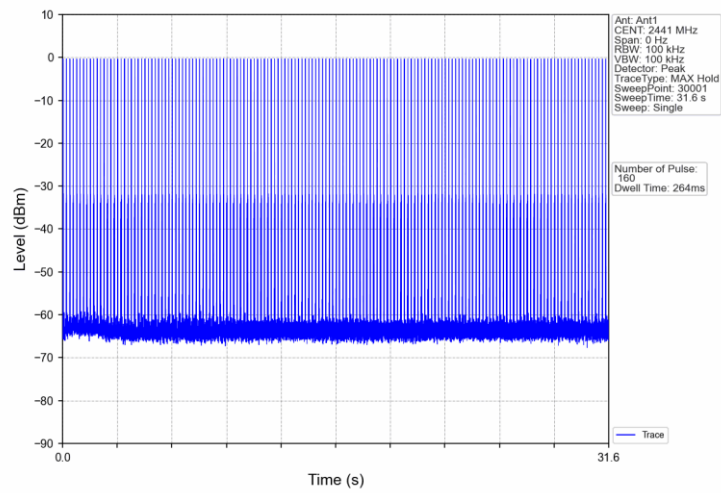

GFSK_DH5_HOPP_Ant1_NTNV

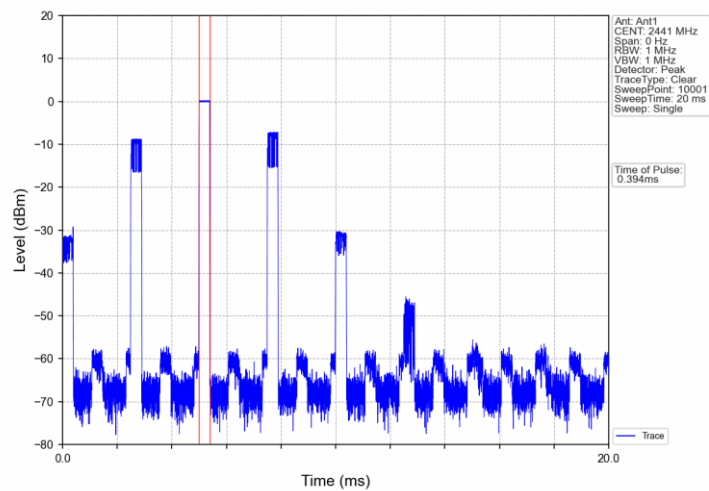

GFSK_DH5_HOPP_Ant1_NTNV

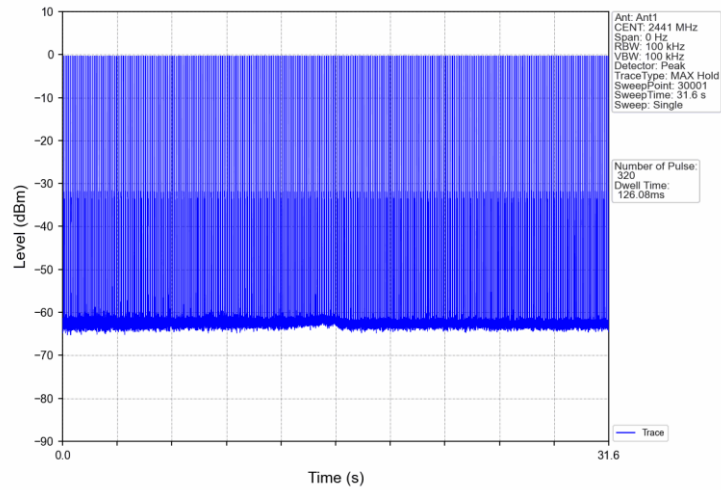

Pi/4DQPSK_2DH1_HOPP_Ant1_NTNV

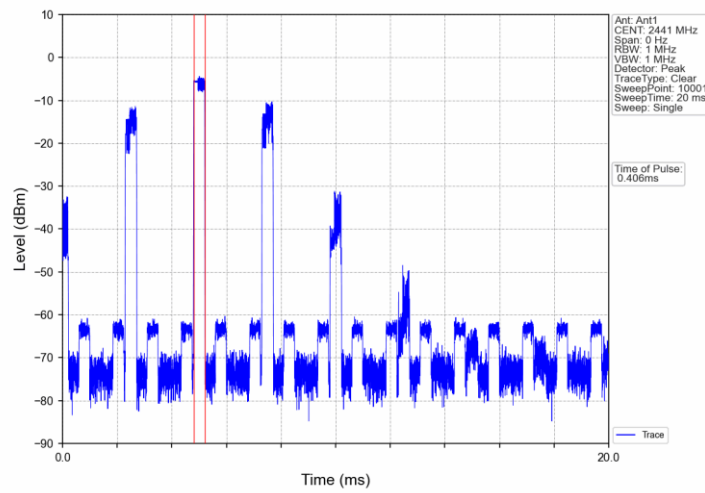

Pi/4DQPSK_2DH1_HOPP_Ant1_NTNV

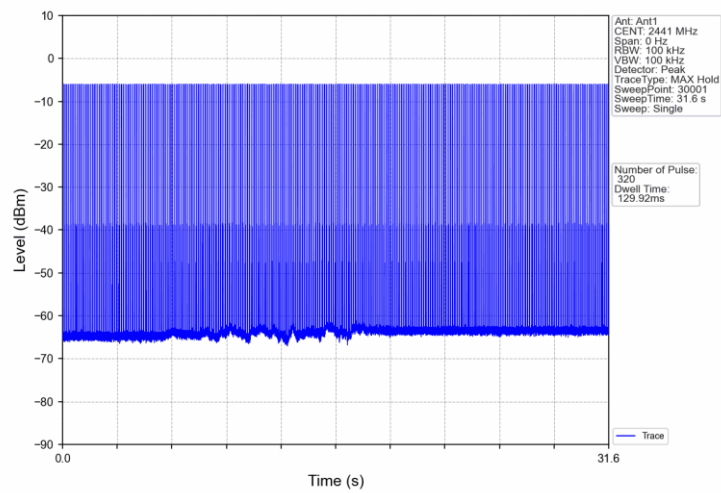

Pi/4DQPSK_2DH3_HOPP_Ant1_NTNV

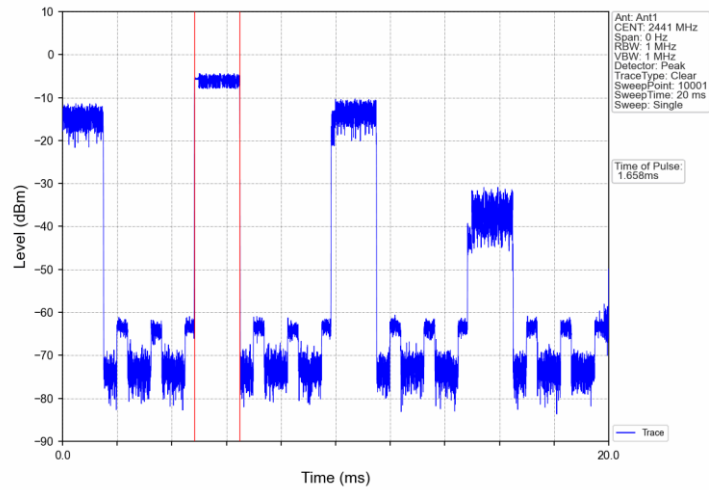

Pi/4DQPSK_2DH3_HOPP_Ant1_NTNV

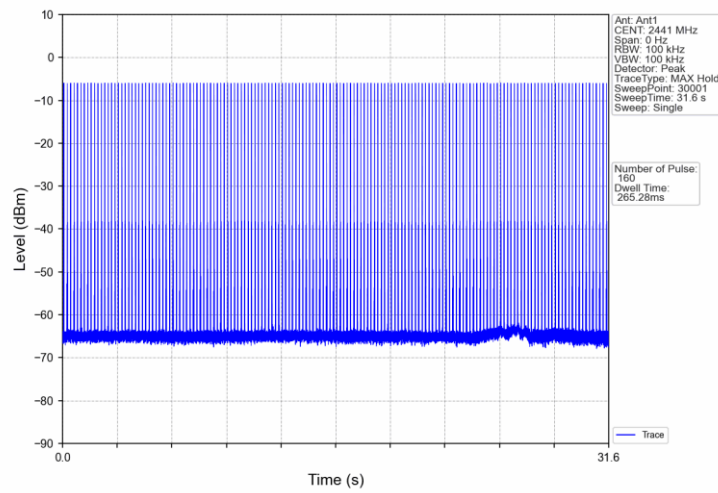

Pi/4DQPSK_2DH5_HOPP_Ant1_NTNV

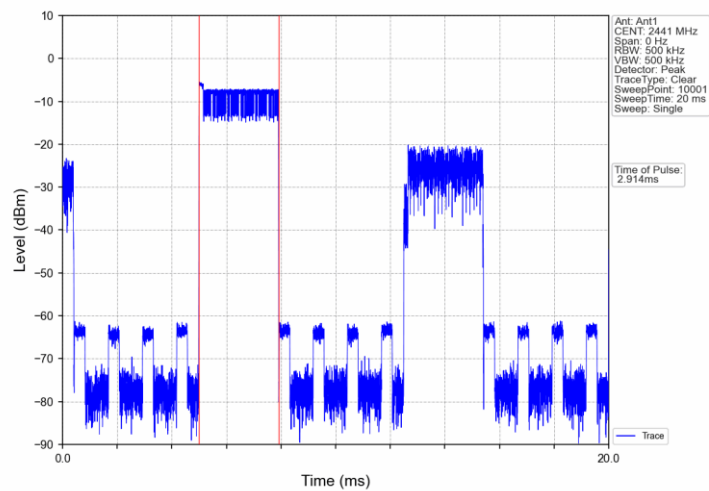

Pi/4DQPSK_2DH5_HOPP_Ant1_NTNV

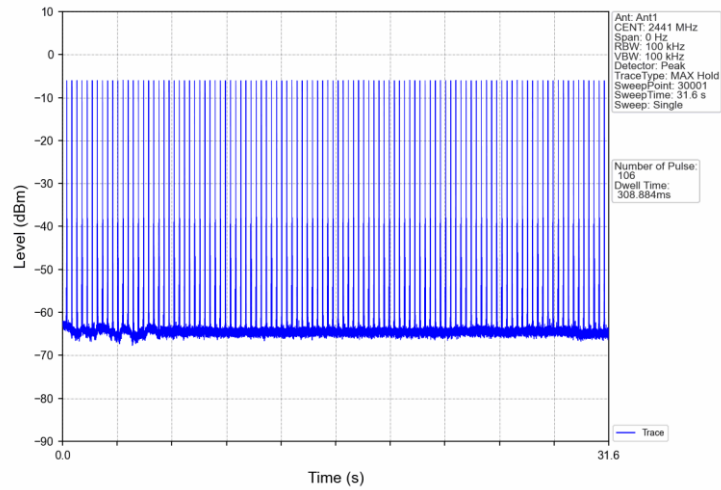

8DPSK_3DH1_HOPP_Ant1_NTNV

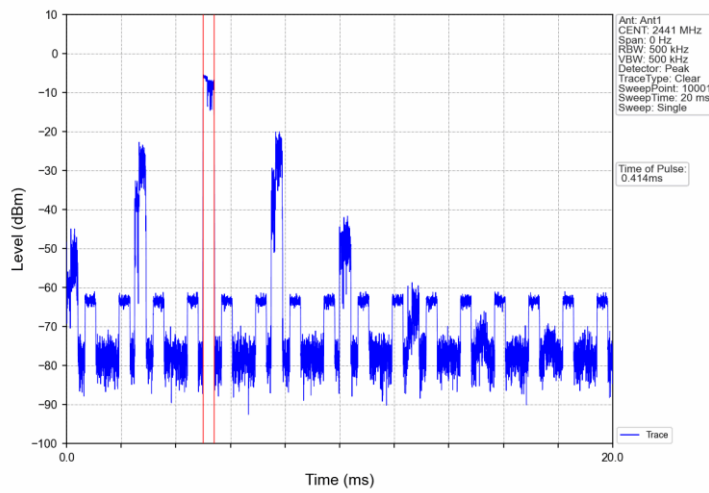

8DPSK_3DH1_HOPP_Ant1_NTNV

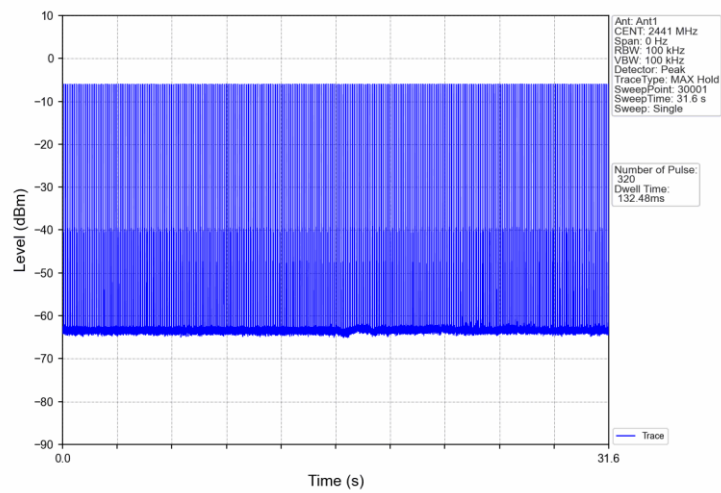

8DPSK_3DH3_HOPP_Ant1_NTNV

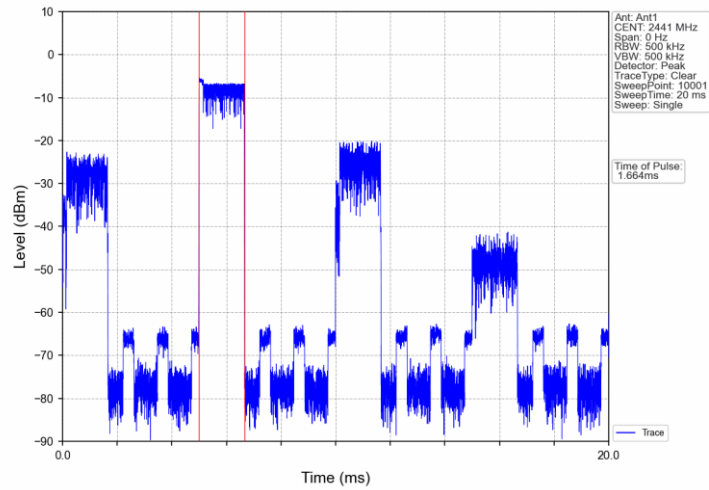

8DPSK_3DH3_HOPP_Ant1_NTNV

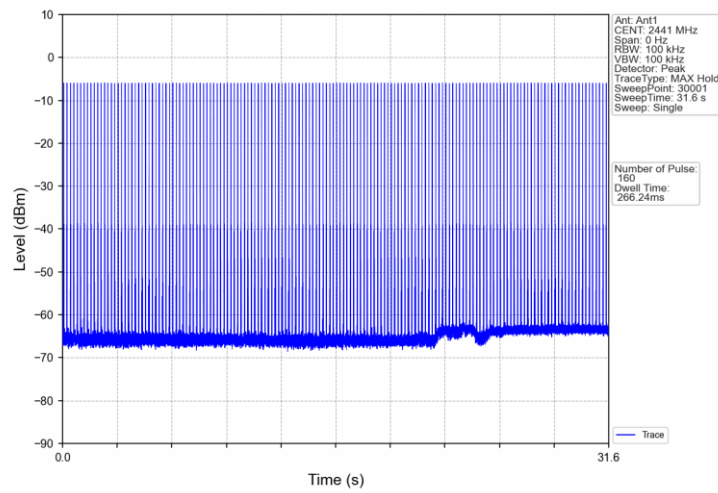

8DPSK_3DH5_HOPP_Ant1_NTNV

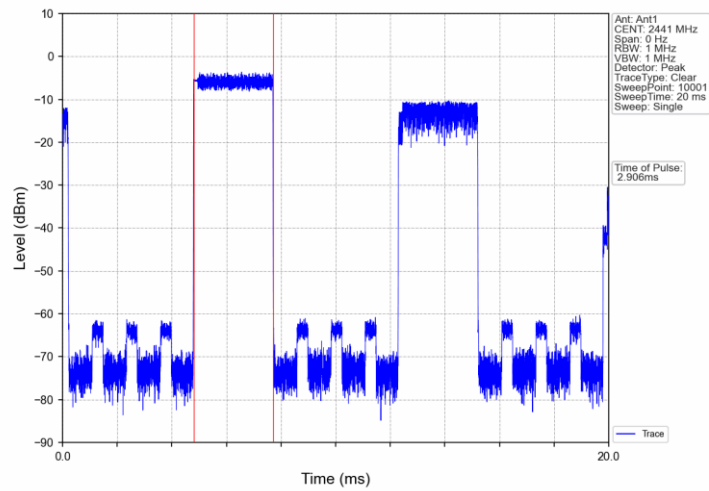

8DPSK_3DH5_HOPP_Ant1_NTNV

