

TEST REPORT

Report No.: BCTC2403657267-1E

Applicant: Shenzhen usbangel Technology Limited

Product Name: Multi-Function Power Bank

Test Model: T31Pro

Tested Date: 2024-03-07 to 2024-03-15

Issued Date: 2024-03-15

Shenzhen BCTC Testing Co., Ltd.



FCC ID: 2AX87-T31PRO

Product Name: Multi-Function Power Bank
Trademark: N/A
Model/Type reference: T31Pro
QP-1020MB
Prepared For: Shenzhen usbangel Technology Limited
Address: 402, 502, 602, No.28 Hongyuan Road, Pingdong Community, Pingdi Sub-District.
Longgang District. Shenzhen, PRC.
Manufacturer: Shenzhen usbangel Technology Limited
Address: 402, 502, 602, No.28 Hongyuan Road, Pingdong Community, Pingdi Sub-District.
Longgang District. Shenzhen, PRC.
Prepared By: Shenzhen BCTC Testing Co., Ltd.
Address: 1-2/F., Building B, Pengzhou Industrial Park, No.158, Fuyuan 1st Road,
Zhancheng, Fuhai Subdistrict, Bao'an District, Shenzhen, Guangdong, China
Sample Received Date: 2024-03-07
Sample tested Date: 2024-03-07 to 2024-03-15
Issue Date: 2024-03-15
Report No.: BCTC2403657267-1E
Test Standards: FCC Part15.209
ANSI C63.10-2013
Test Results: PASS

Tested by:

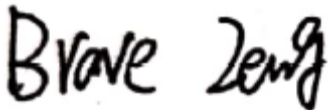

Brave Zeng/ Project Handler

Approved by:



Zero Zhou/Reviewer

The test report is effective only with both signature and specialized stamp. This result(s) shown in this report refer only to the sample(s) tested. Without written approval of Shenzhen BCTC Testing Co., Ltd, this report can't be reproduced except in full. The tested sample(s) and the sample information are provided by the client.

Table Of Content

	Page
Test Report Declaration	
1. Version	4
2. Test Summary	5
3. Measurement Uncertainty	6
4. Product Information And Test Setup	7
4.1 Product Information.....	7
4.2 Support Equipment	7
4.3 Test Setup Configuration	8
4.4 Test Mode	8
5. Test Facility And Test Instrument Used.....	9
5.1 Test Facility.....	9
5.2 Test Instrument Used.....	9
6. Conducted Emissions.....	11
6.1 Block Diagram Of Test Setup.....	11
6.2 Limit	11
6.3 Test Procedure	11
6.4 EUT Operating Conditions	11
6.5 Test Result.....	12
7. Radiated Emissions.....	16
7.1 Block Diagram Of Test Setup.....	16
7.2 Limit	17
7.3 Test Procedure	17
7.4 Test Result.....	19
8. Bandwidth Test.....	27
8.1 Test Setup	27
8.2 Test Procedure	27
8.3 Test Result.....	28
9. Antenna Requirements.....	29
10. EUT Photographs.....	30
11. EUT Test Setup Photographs.....	31

(Note: N/A Means Not Applicable)

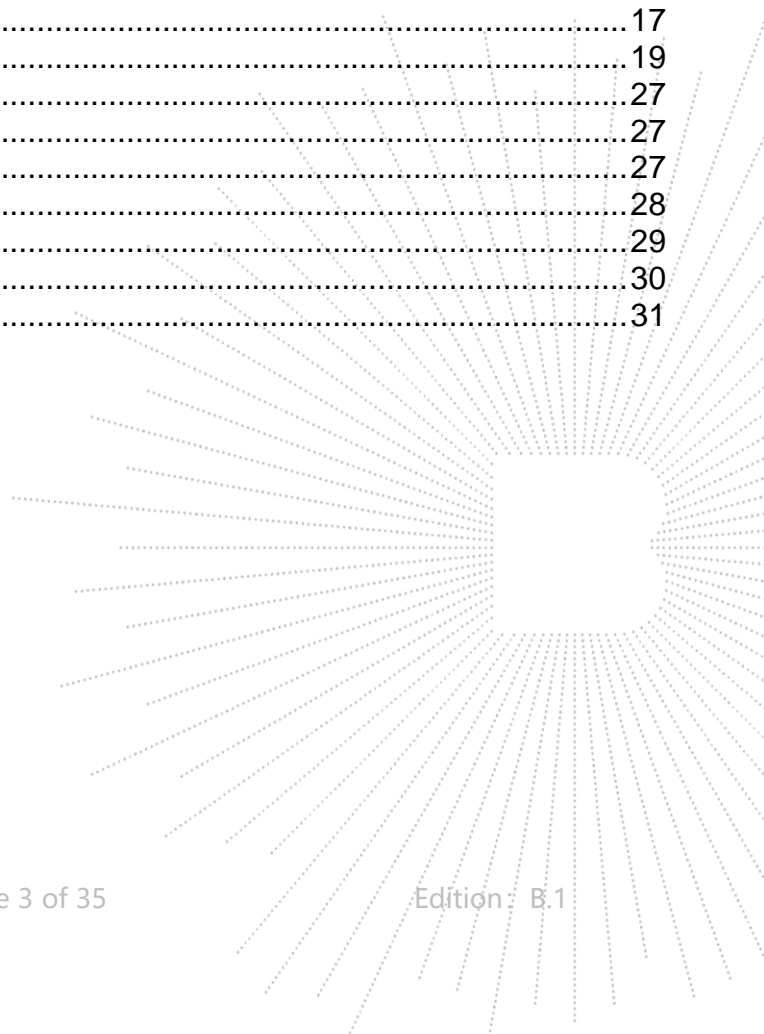

1. Version

Report No.	Issue Date	Description	Approved
BCTC2403657267-1E	2024-03-15	Original	Valid

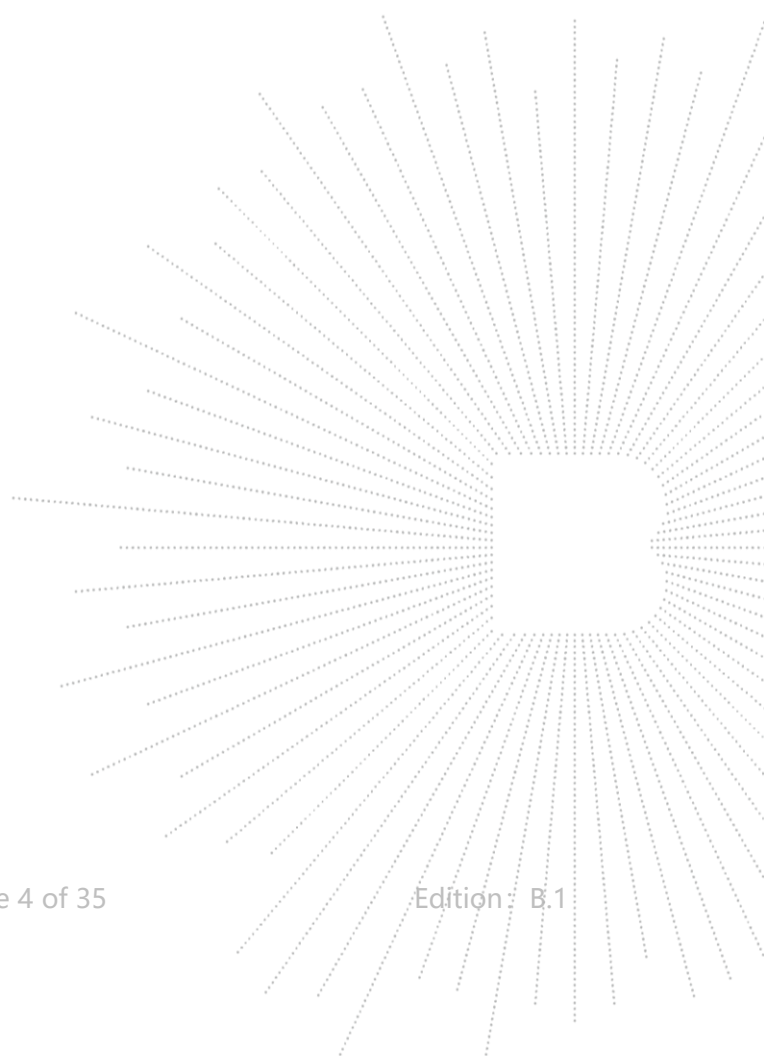

2. Test Summary

The Product has been tested according to the following specifications:

No.	Test Parameter	Clause No	Results
1	Conducted Emission	15.207	PASS
2	Radiated Emission	15.209	PASS
3	20dB Bandwidth	15.215	PASS
4	Antenna Requirement	15.203	PASS

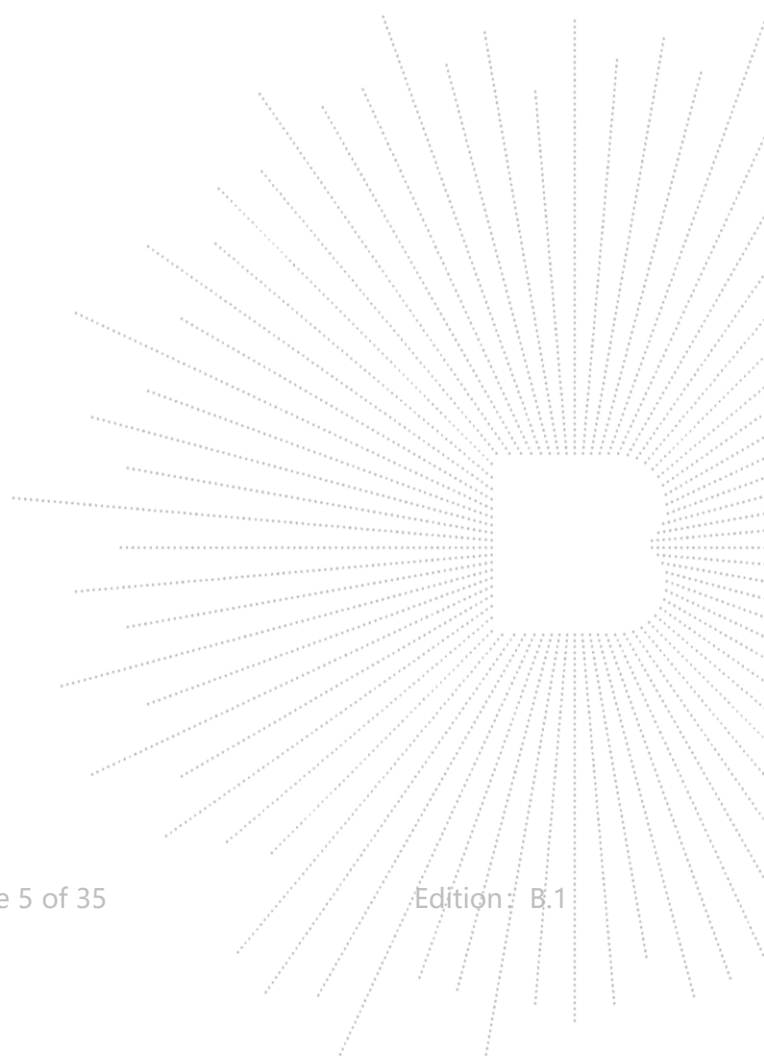

3. Measurement Uncertainty

Where relevant, the following measurement uncertainty levels have been estimated for tests performed on the Product as specified in CISPR 16-4-2. This uncertainty represents an expanded uncertainty expressed at approximately the 95% confidence level using a coverage factor of $k=2$.

No.	Item	Uncertainty
1	3m chamber Radiated spurious emission(9kHz-30MHz)	U=3.7dB
2	3m chamber Radiated spurious emission(30MHz-1GHz)	U=4.3dB
3	3m chamber Radiated spurious emission(1GHz-18GHz)	U=4.5dB
4	3m chamber Radiated spurious emission(18GHz-40GHz)	U=3.34dB
5	Conducted Emission(150kHz-30MHz)	U=3.20dB
6	Conducted Adjacent channel power	U=1.38dB
7	Conducted output power uncertainty Above 1G	U=1.576dB
8	Conducted output power uncertainty below 1G	U=1.28dB
9	humidity uncertainty	U=5.3%
10	Temperature uncertainty	U=0.59°C

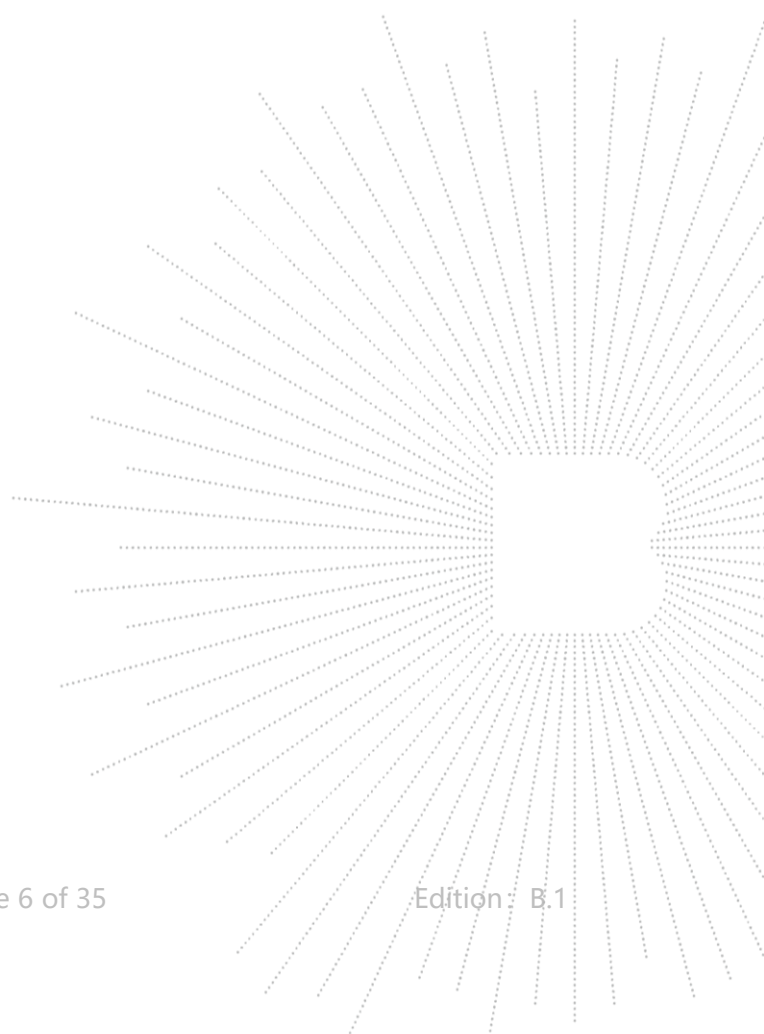

4. Product Information And Test Setup

4.1 Product Information

Model/Type reference:	T31Pro QP-1020MB
Model differences:	All the model are the same circuit and RF module, except model names and appearance of the color.
Hardware Version:	N/A
Software Version:	N/A
Product Description:	Multi-Function Power Bank
Operation Frequency:	110kHz-205kHz
Modulation:	ASK
Antenna installation:	loop coil antenna
	As an Adapter: Input:100-240V~50/60Hz,0.5A Max Output1 USB-A: (5.0V=3.0A) 15.0W(Max) Output2 USB-C: (5.0V=3.0A) 15.0W(Max) Wireless Output: 5.0W(Max) Total Output:15.0W(Max) USB-A+USB-C: 5.0V=3.0A (15.0W Max) (USB-A+USB-C)+Wireless: 5.0V=3.0A(15.0W Max)
Ratings:	As a Power Bank Input (USB-C):5.0V=3.0A, 9.0V=2.0A Output1(USB-C): 5.0V=3.0A, 9.0V=2.22A,12.0V=1.67A Output2(USB-A): 5.0V=3.0A, 9.0V=2.0A,12.0V=1.5A Wireless Output: 5.0W/7.5W/10.0W/15.0W(Max) USB-A+USB-C: 5.0V=3.0A (15.0W Max) (USB-A+USB-C)+Wireless: 5.0V=3.0A(15.0W Max) Total Output 20.0W(Max)

Cable of Product

No.	Cable Type	Quantity	Provider	Length (m)	Shielded	Note
1	--	--	Applicant	---	Yes/No	With a ferrite ring in mid Detachable
2.	--	--	BCTC	---	Yes	--

4.2 Support Equipment

No.	Device Type	Brand	Model	Series No.	Note
1.	Adapter	---	---	---	Auxiliary
2.	Wireless charging load	---	---	---	Auxiliary

Notes:

- All the equipment/cables were placed in the worst-case configuration to maximize the emission during the test.
- Grounding was established in accordance with the manufacturer's requirements and conditions for the intended use.

4.3 Test Setup Configuration

See test photographs attached in *EUT TEST SETUP PHOTOGRAPHS* for the actual connections between Product and support equipment.

4.4 Test Mode

To investigate the maximum EMI emission characteristics generates from EUT, the test system was pre-scanning tested base on the consideration of following EUT operation mode or test configuration mode which possible have effect on EMI emission level. Each of these EUT operation mode(s) or test configuration mode(s) mentioned above was evaluated respectively.

AC Mode	Test Mode 1	Adapter+Wireless Charging 5.0W
	Test Mode 2	OWN AC+Wireless Charging 5.0W
DC Mode	Test Mode 3	Wireless Charging 5.0W
	Test Mode 4	Wireless Charging 7.5W
	Test Mode 5	Wireless Charging 10.0W
	Test Mode 6	Wireless Charging 15.0W
	Test Mode 7	Output 1(USB-C): 5.0V=1.0A+ Output 2(USB-A): 5.0V=1.0A+ Wireless 5.0W

Note:

All test mode were tested and passed, only Conducted Emissions, Radiated Emissions shows (*) is the worst case mode which were recorded in this report.

Ac mode only supports 5W wireless charging

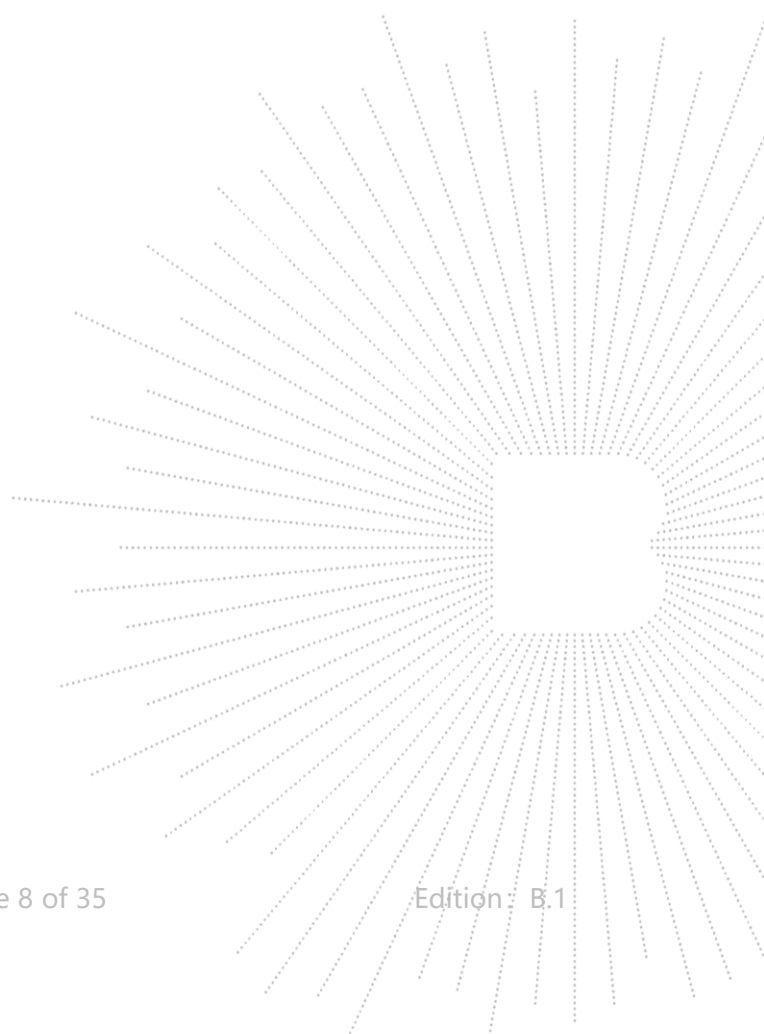

5. Test Facility And Test Instrument Used

5.1 Test Facility

All measurement facilities used to collect the measurement data are located at Shenzhen BCTC Testing Co., Ltd. Address: 1-2/F., Building B, Pengzhou Industrial Park, No.158, Fuyuan 1st Road, Zhancheng, Fuhai Subdistrict, Bao'an District, Shenzhen, Guangdong, China. The site and apparatus are constructed in conformance with the requirements of ANSI C63.4 and CISPR 16-1-1 other equivalent standards.

FCC Test Firm Registration Number: 712850

A2LA certificate registration number is: CN1212

ISED Registered No.: 23583

ISED CAB identifier: CN0017

5.2 Test Instrument Used

Conducted Emissions Test					
Equipment	Manufacturer	Model#	Serial#	Last Cal.	Next Cal.
Receiver	R&S	ESR3	102075	May 15, 2023	May 14, 2024
LISN	R&S	ENV216	101375	May 15, 2023	May 14, 2024
Software	Frad	EZ-EMC	EMC-CON 3A1	\	\
Pulse limiter	Schwarzbeck	VTSD9561-F	01323	Sept. 22, 2023	Sept. 21, 2024

RF Conducted Test					
Equipment	Manufacturer	Model#	Serial#	Last Cal.	Next Cal.
Power Meter	Keysight	E4419	\	May 15, 2023	May 14, 2024
Power Sensor (AV)	Keysight	E9300A	\	May 15, 2023	May 14, 2024
Signal Analyzer20kHz-26.5GHz	Keysight	N9020A	MY49100060	May 15, 2023	May 14, 2024
Spectrum Analyzer9kHz-40GHz	R&S	FSP40	100363	May 15, 2023	May 14, 2024

Radiated Emissions Test (966 Chamber01)					
Equipment	Manufacturer	Model#	Serial#	Last Cal.	Next Cal.
966 chamber	ChengYu	966 Room	966	May 15, 2023	May 14, 2026
Receiver	R&S	ESR3	102075	May 15, 2023	May 14, 2024
Receiver	R&S	ESRP	101154	May 15, 2023	May 14, 2024
Amplifier	Schwarzbeck	BBV9744	9744-0037	May 15, 2023	May 14, 2024
TRILOG Broadband Antenna	Schwarzbeck	VULB9163	942	May 29, 2023	May 28, 2024
Loop Antenna(9KHz -30MHz)	Schwarzbeck	FMZB1519B	00014	May 31, 2023	May 30, 2024
Amplifier	SKET	LAPA_01G18 G-45dB	\	May 15, 2023	May 14, 2024
Horn Antenna	Schwarzbeck	BBHA9120D	1541	May 31, 2023	May 30, 2024
Amplifier(18G Hz-40GHz)	MITEQ	TTA1840-35-HG	2034381	May 15, 2023	May 14, 2024
Horn Antenna(18G Hz-40GHz)	Schwarzbeck	BBHA9170	00822	May 31, 2023	May 30, 2024
Spectrum Analyzer9kHz-40GHz	R&S	FSP40	100363	May 15, 2023	May 14, 2024
Software	Frad	EZ-EMC	FA-03A2 RE	\	\

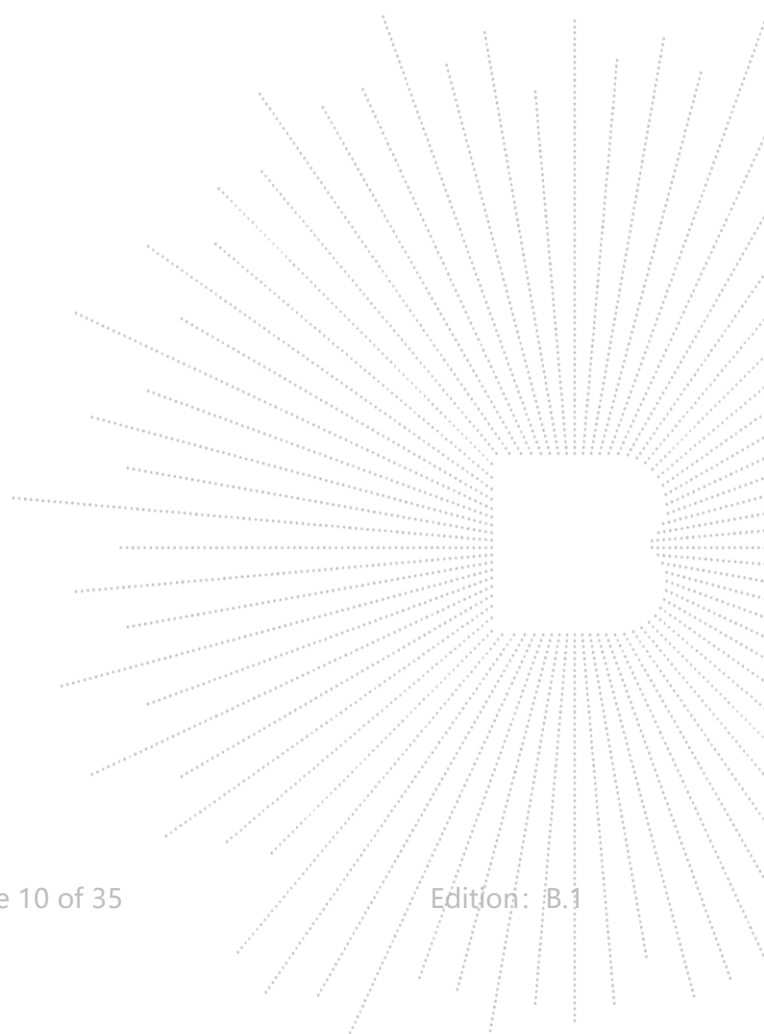

6. Conducted Emissions

6.1 Block Diagram Of Test Setup

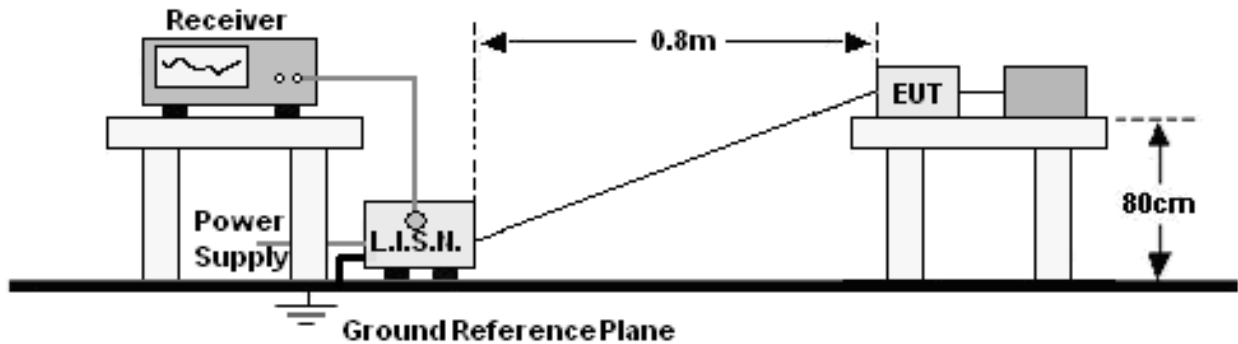

6.2 Limit

FREQUENCY (MHz)	Limit (dBuV)	
	Quas-peak	Average
0.15 -0.5	66 - 56 *	56 - 46 *
0.50 -5.0	56.00	46.00
5.0 -30.0	60.00	50.00

Notes:
 1. *Decreasing linearly with logarithm of frequency.
 2. The lower limit shall apply at the transition frequencies.

6.3 Test Procedure

Receiver Parameters	Setting
Attenuation	10 dB
Start Frequency	0.15 MHz
Stop Frequency	30 MHz
IF Bandwidth	9 kHz

- The Product was placed on a nonconductive table 0.8 m above the horizontal ground reference plane, and 0.4 m from the vertical ground reference plane, and connected to the main through Line Impedance Stability Network (L.I.S.N).
- The RBW of the receiver was set at 9 kHz in 150 kHz ~ 30MHz with Peak and AVG detector in Max Hold mode. Run the receiver's pre-scan to record the maximum disturbance generated from Product in all power lines in the full band.
- For each frequency whose maximum record was higher or close to limit, measure its QP and AVG values and record.

6.4 EUT Operating Conditions

The EUT was configured for testing in a typical fashion (as a customer would normally use it). The EUT has been programmed to continuously transmit during test. This operating condition was tested and used to collect the included data.

6.5 Test Result

Temperature:	26 °C	Relative Humidity:	54%
Pressure:	101kPa	Phase :	L
Test Voltage :	AC 120V/60Hz	Test Mode:	Mode 1

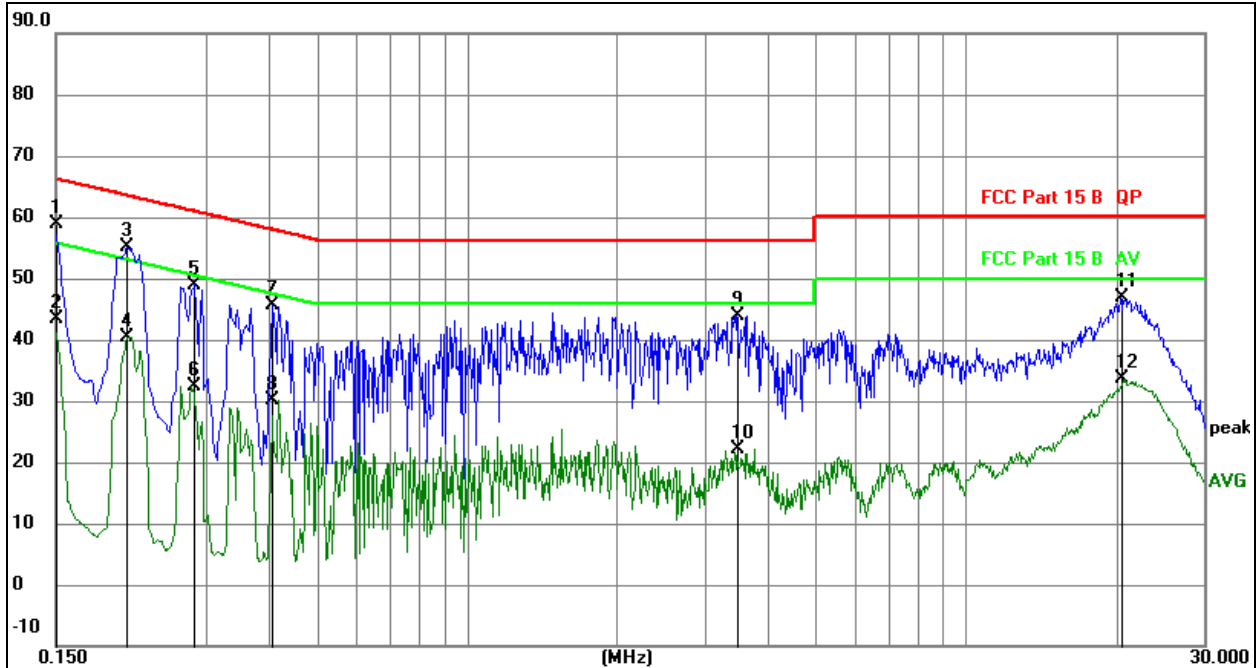

Remark:

1. All readings are Quasi-Peak and Average values.
2. Factor = Insertion Loss + Cable Loss.
3. Measurement=Reading Level+ Correct Factor
4. Over=Measurement-Limit

No.	Mk.	Freq. MHz	Reading Level	Correct Factor dB	Measure- ment dBuV	Limit dBuV	Over dB	Detector
1	*	0.1500	39.15	19.73	58.88	66.00	-7.12	QP
2		0.1500	23.56	19.73	43.29	56.00	-12.71	AVG
3		0.2083	35.21	19.83	55.04	63.27	-8.23	QP
4		0.2083	20.67	19.83	40.50	53.27	-12.77	AVG
5		0.2847	29.17	19.83	49.00	60.68	-11.68	QP
6		0.2847	12.66	19.83	32.49	50.68	-18.19	AVG
7		0.4061	25.79	19.84	45.63	57.73	-12.10	QP
8		0.4061	10.18	19.84	30.02	47.73	-17.71	AVG
9		3.4722	23.39	20.47	43.86	56.00	-12.14	QP
10		3.4722	1.61	20.47	22.08	46.00	-23.92	AVG
11		20.3773	26.84	19.99	46.83	60.00	-13.17	QP
12		20.3773	13.75	19.99	33.74	50.00	-16.26	AVG

Temperature:	26 °C	Relative Humidity:	54%
Pressure:	101kPa	Phase :	N
Test Voltage :	AC 120V/60Hz	Test Mode:	Mode 1

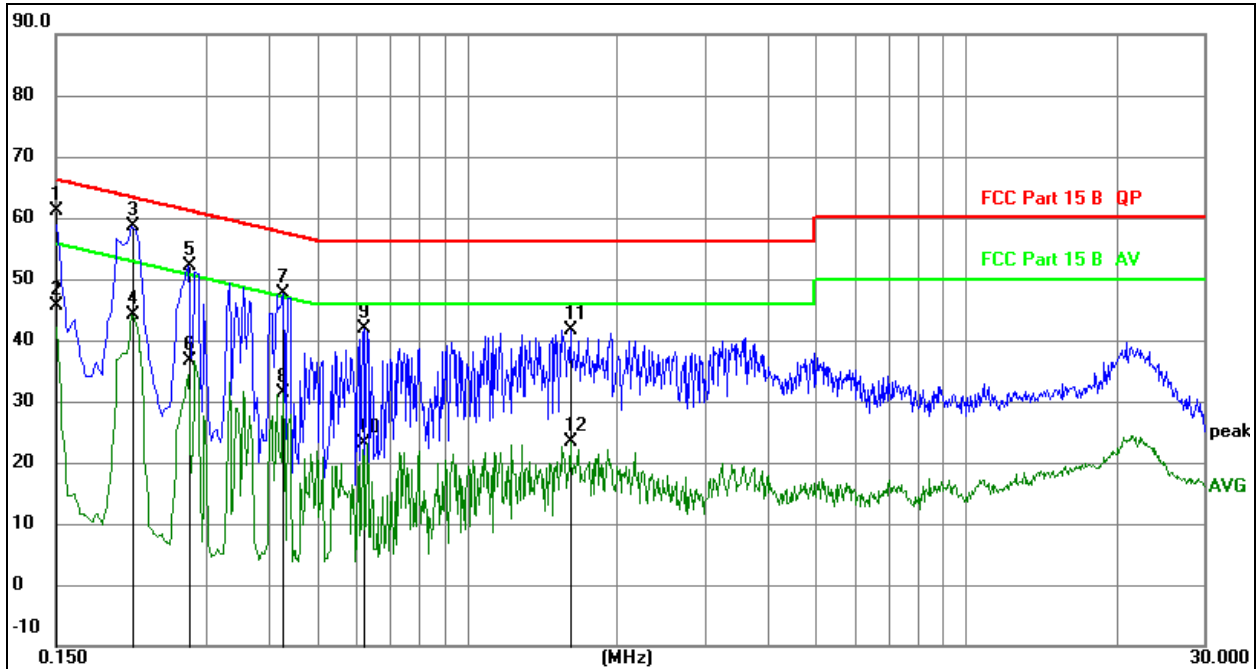
Remark:

1. All readings are Quasi-Peak and Average values.
2. Factor = Insertion Loss + Cable Loss.
3. Measurement=Reading Level+ Correct Factor
4. Over=Measurement-Limit

No.	Mk.	Freq. MHz	Reading Level	Correct Factor dB	Measure- ment dBuV	Limit dBuV	Over dB	Detector
1		0.1500	41.32	19.73	61.05	66.00	-4.95	QP
2		0.1500	25.78	19.73	45.51	56.00	-10.49	AVG
3	*	0.2128	38.76	19.83	58.59	63.10	-4.51	QP
4		0.2128	24.31	19.83	44.14	53.10	-8.96	AVG
5		0.2759	32.30	19.83	52.13	60.94	-8.81	QP
6		0.2759	16.74	19.83	36.57	50.94	-14.37	AVG
7		0.4282	27.84	19.84	47.68	57.29	-9.61	QP
8		0.4282	11.45	19.84	31.29	47.29	-16.00	AVG
9		0.6205	22.02	19.84	41.86	56.00	-14.14	QP
10		0.6205	3.34	19.84	23.18	46.00	-22.82	AVG
11		1.6105	21.67	19.95	41.62	56.00	-14.38	QP
12		1.6105	3.46	19.95	23.41	46.00	-22.59	AVG

Temperature:	26 °C	Relative Humidity:	54%
Pressure:	101kPa	Phase :	L
Test Voltage :	AC 120V/60Hz	Test Mode:	Mode 2

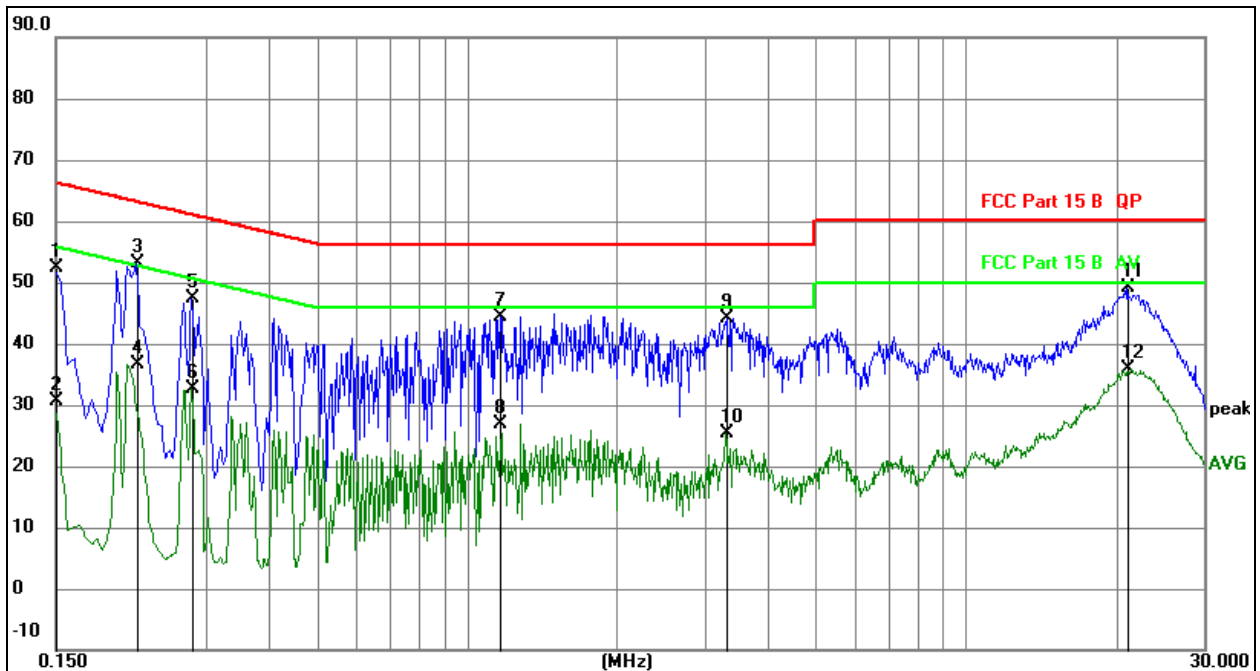
Remark:

1. All readings are Quasi-Peak and Average values.
2. Factor = Insertion Loss + Cable Loss.
3. Measurement=Reading Level+ Correct Factor
4. Over=Measurement-Limit

No. Mk.	Freq. MHz	Reading Level	Correct Factor dB	Measure- ment dBuV	Limit dBuV	Over dB	Detector
1	0.1500	32.55	19.73	52.28	66.00	-13.72	QP
2	0.1500	10.99	19.73	30.72	56.00	-25.28	AVG
3 *	0.2174	33.21	19.83	53.04	62.92	-9.88	QP
4	0.2174	16.72	19.83	36.55	52.92	-16.37	AVG
5	0.2803	27.60	19.83	47.43	60.81	-13.38	QP
6	0.2803	12.79	19.83	32.62	50.81	-18.19	AVG
7	1.1657	24.49	19.95	44.44	56.00	-11.56	QP
8	1.1657	6.81	19.95	26.76	46.00	-19.24	AVG
9	3.3105	23.76	20.42	44.18	56.00	-11.82	QP
10	3.3105	4.89	20.42	25.31	46.00	-20.69	AVG
11	21.0355	29.25	19.99	49.24	60.00	-10.76	QP
12	21.0355	15.84	19.99	35.83	50.00	-14.17	AVG

Temperature:	26 °C	Relative Humidity:	54%
Pressure:	101kPa	Phase :	N
Test Voltage :	AC 120V/60Hz	Test Mode:	Mode 2

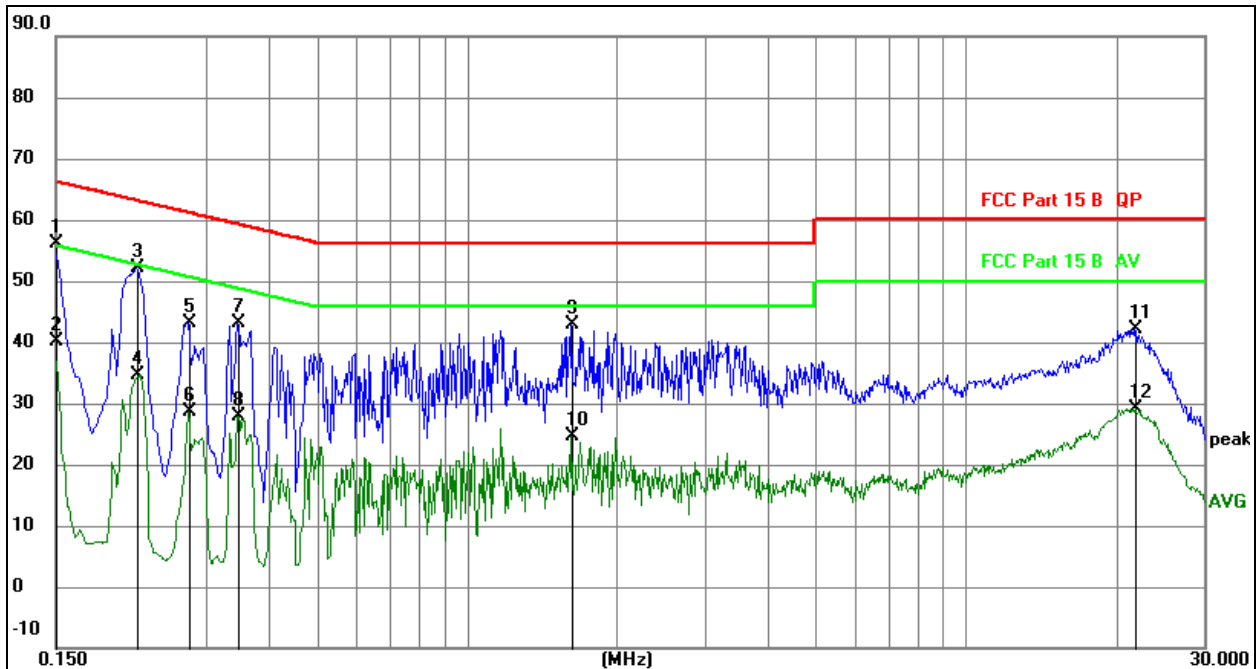
Remark:

1. All readings are Quasi-Peak and Average values.
2. Factor = Insertion Loss + Cable Loss.
3. Measurement=Reading Level+ Correct Factor
4. Over=Measurement-Limit

No.	Mk.	Freq. MHz	Reading Level	Correct Factor dB	Measure- ment dBuV	Limit dBuV	Over dB	Detector
1	*	0.1500	36.28	19.73	56.01	66.00	-9.99	QP
2		0.1500	20.43	19.73	40.16	56.00	-15.84	AVG
3		0.2175	32.38	19.83	52.21	62.91	-10.70	QP
4		0.2175	14.75	19.83	34.58	52.91	-18.33	AVG
5		0.2760	23.40	19.83	43.23	60.94	-17.71	QP
6		0.2760	8.91	19.83	28.74	50.94	-22.20	AVG
7		0.3480	23.25	19.83	43.08	59.01	-15.93	QP
8		0.3480	8.08	19.83	27.91	49.01	-21.10	AVG
9		1.6215	22.88	19.95	42.83	56.00	-13.17	QP
10		1.6215	4.78	19.95	24.73	46.00	-21.27	AVG
11		21.7410	22.11	19.99	42.10	60.00	-17.90	QP
12		21.7410	9.15	19.99	29.14	50.00	-20.86	AVG

7. Radiated Emissions

7.1 Block Diagram Of Test Setup

(A) Radiated Emission Test-Up Frequency Below 30MHz

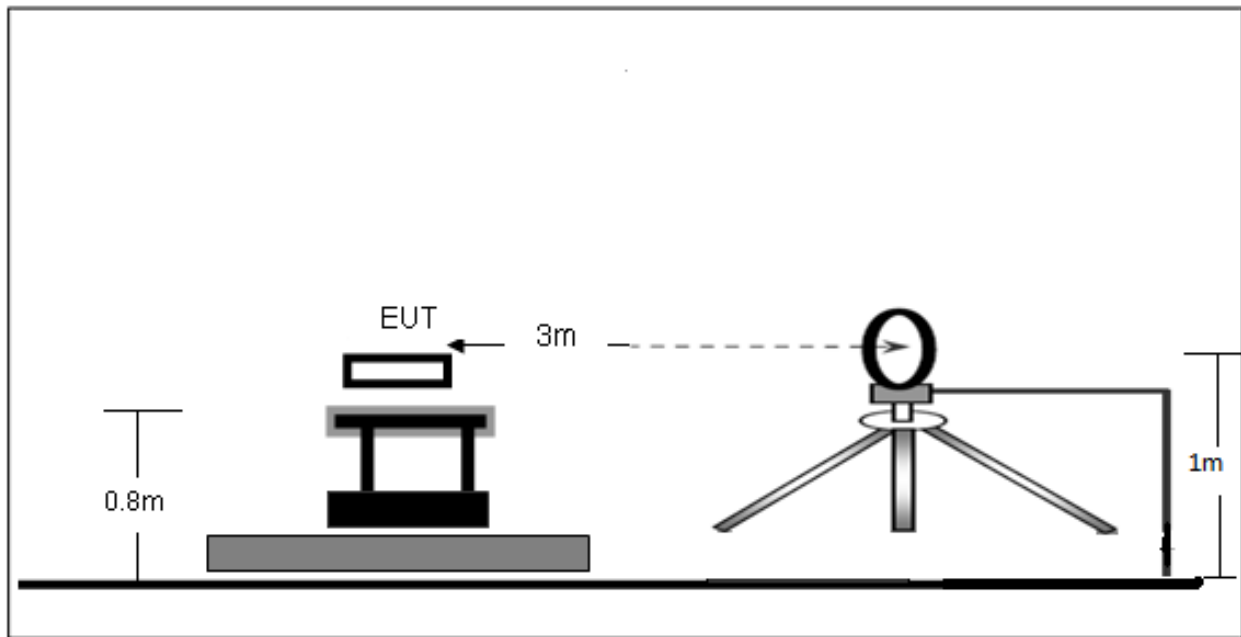

(B) Radiated Emission Test-Up Frequency 30MHz~1GHz

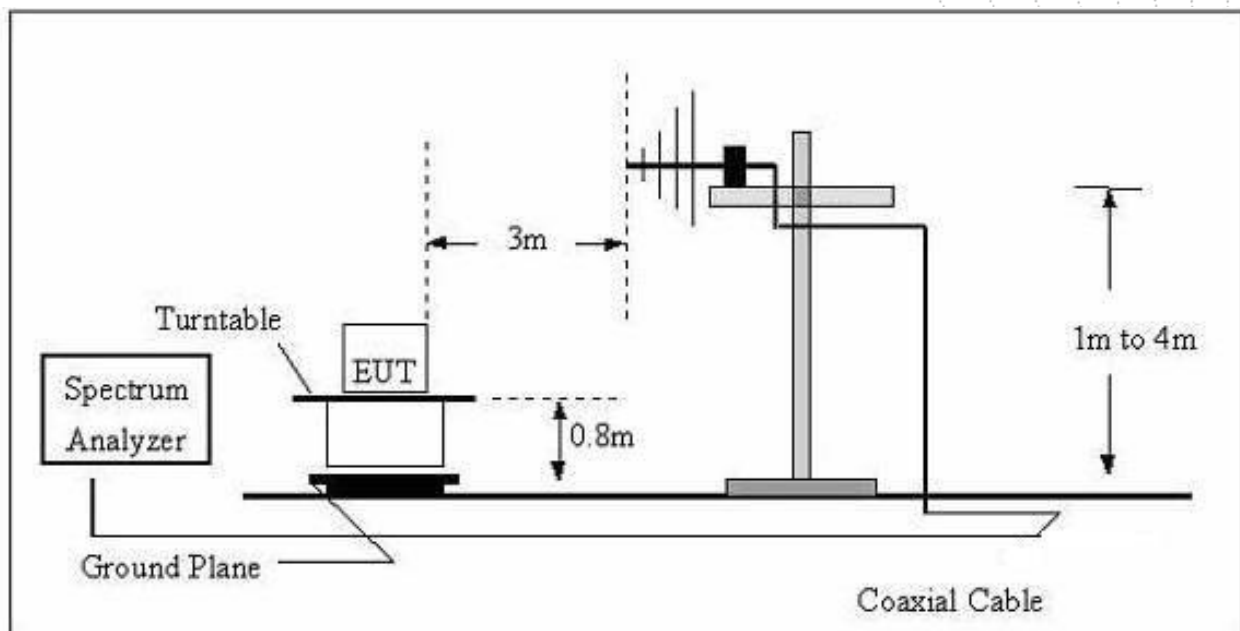

7.2 Limit

FCC §15.209; §15.205.

Test Standard	FCC Part15 C Section 15.209 and 15.205				
Test Limit	Frequency (MHz)	Field strength (microvolt/meter)	Limit (dBuV/m)	Remark	Measurement distance (m)
	0.009MHz~0.490MHz	2400/F(kHz)	-	-	300
	0.490MHz-1.705MHz	24000/F(kHz)	-	-	30
	1.705MHz-30MHz	30	-	-	30
	30MHz~88MHz	100	40.0	Quasi-peak	3
	88MHz~216MHz	150	43.5	Quasi-peak	3
	216MHz~960MHz	200	46.0	Quasi-peak	3
	960MHz~1000MHz	500	54.0	Quasi-peak	3
	Above 1000MHz	500	54.0	Average	3
-		74.0	Peak	3	

7.3 Test Procedure

Receiver Parameter	Setting
Attenuation	Auto
9kHz~150kHz	RBW 200Hz for QP
150kHz~30MHz	RBW 9kHz for QP
30MHz~1000MHz	RBW 120kHz for QP

Below 1GHz test procedure as below:

- The EUT was placed on the top of a rotating table 0.8 meters above the ground at a 3 meter semi-anechoic chamber. The table was rotated 360 degrees to determine the position of the highest radiation.
- The EUT was set 3 meters away from the interference-receiving antenna, which was mounted on the top of a variable-height antenna tower.
- The antenna height is varied from one meter to four meters above the ground to determine the maximum value of the field strength. Both horizontal and vertical polarizations of the antenna are set to make the measurement.
- For each suspected emission, the EUT was arranged to its worst case and then the antenna was tuned to heights from 1 meter to 4 meters (for the test frequency of below 30MHz, the antenna was tuned to heights 1 meter) and the rotatable table was turned from 0 degrees to 360 degrees to find the maximum reading.
- The test-receiver system was set to Peak Detect Function and Specified Bandwidth with Maximum Hold Mode.

f. If the emission level of the EUT in peak mode was 10dB lower than the limit specified, then testing could be stopped and the peak values of the EUT would be reported. Otherwise the emissions that did not have 10dB margin would be re-tested one by one using peak, quasi-peak or average method as specified and then reported in a data sheet.

Above 1GHz test procedure as below:

g. Different between above is the test site, change from Semi- Anechoic Chamber to fully Anechoic Chamber and change form table 0.8 metre to 1.5 metre(Above 18GHz the distance is 1 meter and table is 1.5 metre).

h. Test the EUT in the lowest channel ,the middle channel ,the Highest channel.

Note:

Both horizontal and vertical antenna polarities were tested and performed pretest to three orthogonal axis. The worst case emissions were reported.

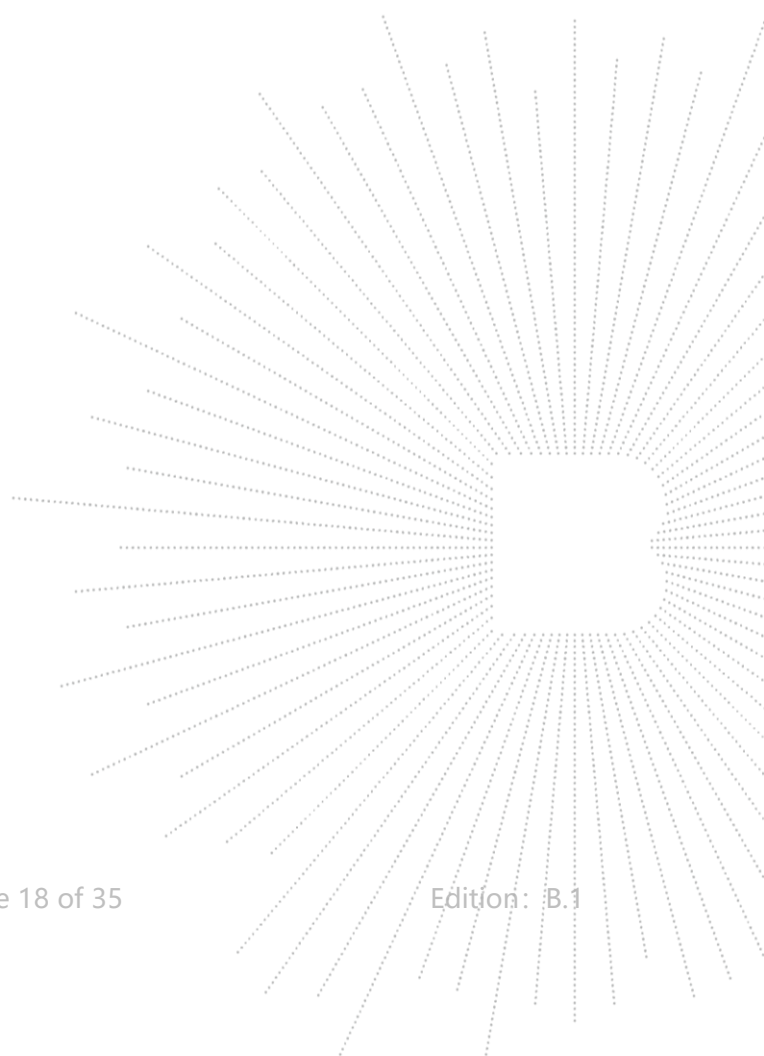

7.4 Test Result

Between 9kHz – 30MHz

Temperature:	26°C	Relative Humidity:	54%
Pressure:	101 kPa	Test Voltage :	AC 120V/60Hz
Test Mode :	Mode 2	Polarization :	Coaxial

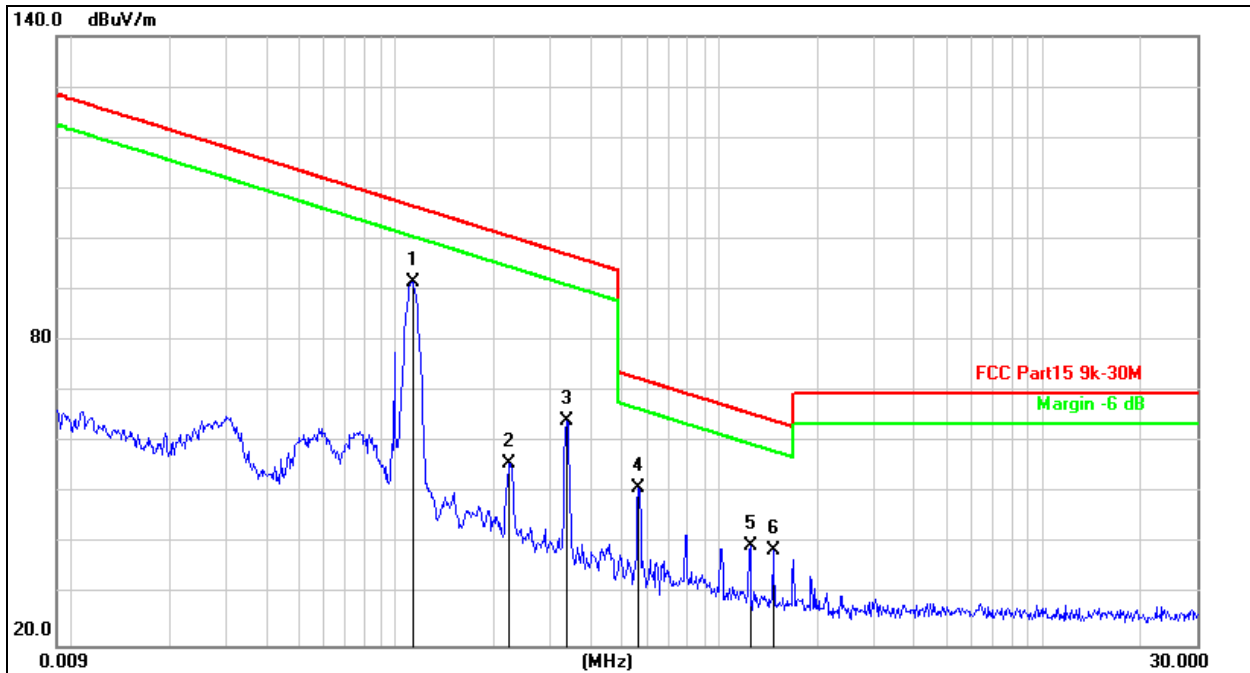

Remark:

1. Factor = Antenna Factor + Cable Loss – Pre-amplifier.
2. Measurement=Reading Level+ Correct Factor
3. Over=Measurement-Limit

No.	Mk.	Freq. MHz	Reading Level dBuV	Correct Factor dB	Measure- ment dBuV/m	Limit dB/m	Over dB	Detector
1	*	0.1131	99.04	-7.51	91.53	106.5	-15.01	peak
2		0.2253	63.65	-7.76	55.89	100.5	-44.66	peak
3		0.3379	71.84	-7.68	64.16	97.03	-32.87	peak
4		0.5635	58.49	-7.50	50.99	72.59	-21.60	peak
5		1.2478	46.97	-7.35	39.62	65.70	-26.08	peak
6		1.4676	46.15	-7.34	38.81	64.30	-25.49	peak

Temperature:	26°C	Relative Humidity:	54%
Pressure:	101 kPa	Test Voltage :	AC 120V/60Hz
Test Mode :	Mode 2	Polarization :	Coplanar

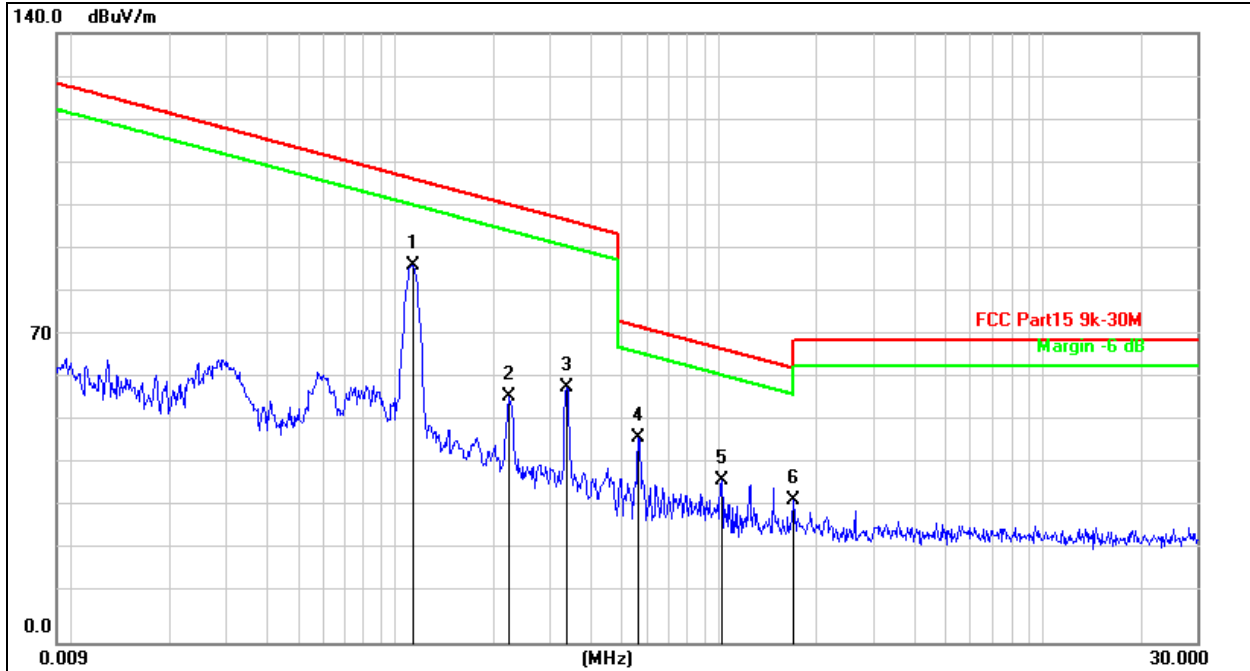

Remark:

1. Factor = Antenna Factor + Cable Loss – Pre-amplifier.
2. Measurement=Reading Level+ Correct Factor
3. Over=Measurement-Limit

No.	Mk.	Freq. MHz	Reading Level dBuV	Correct Factor dB	Measure- ment dBuV/m	Limit dB/m	Over dB	Detector
1	*	0.1131	94.28	-7.51	86.77	106.5	-19.77	peak
2		0.2253	64.19	-7.76	56.43	100.5	-44.12	peak
3		0.3379	66.16	-7.68	58.48	97.03	-38.55	peak
4		0.5635	54.60	-7.50	47.10	72.59	-25.49	peak
5		1.0188	44.79	-7.36	37.43	67.46	-30.03	peak
6		1.6983	40.09	-7.33	32.76	63.03	-30.27	peak

Note: The worst AC voltage mode is Mode2.

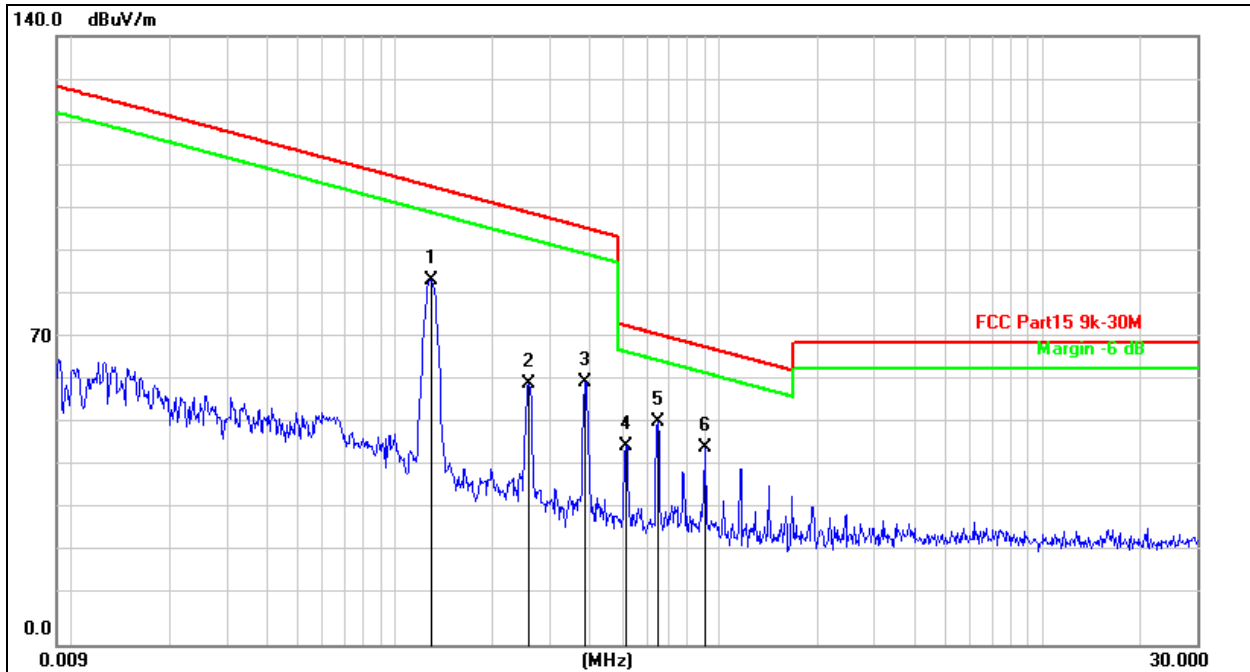
Temperature:	26°C	Relative Humidity:	54%
Pressure:	101 kPa	Test Voltage :	DC 3.7V
Test Mode :	Mode 6	Polarization :	Coaxial

Remark:

1. Factor = Antenna Factor + Cable Loss – Pre-amplifier.
2. Measurement=Reading Level+ Correct Factor
3. Over=Measurement-Limit

No.	Mk.	Freq. MHz	Reading Level dBuV	Correct Factor dB	Measure- ment dBuV/m	Limit dB/m	Over dB	Detector
1		0.1287	91.40	-7.54	83.86	105.4	-21.55	peak
2		0.2587	67.69	-7.74	59.95	99.35	-39.40	peak
3		0.3849	68.17	-7.65	60.52	95.90	-35.38	peak
4		0.5154	53.34	-7.55	45.79	73.36	-27.57	peak
5	*	0.6468	58.68	-7.42	51.26	71.40	-20.14	peak
6		0.9021	52.58	-7.36	45.22	68.51	-23.29	peak

Temperature:	26°C	Relative Humidity:	54%
Pressure:	101 kPa	Test Voltage :	DC 3.7V
Test Mode :	Mode 6	Polarization :	Coplanar

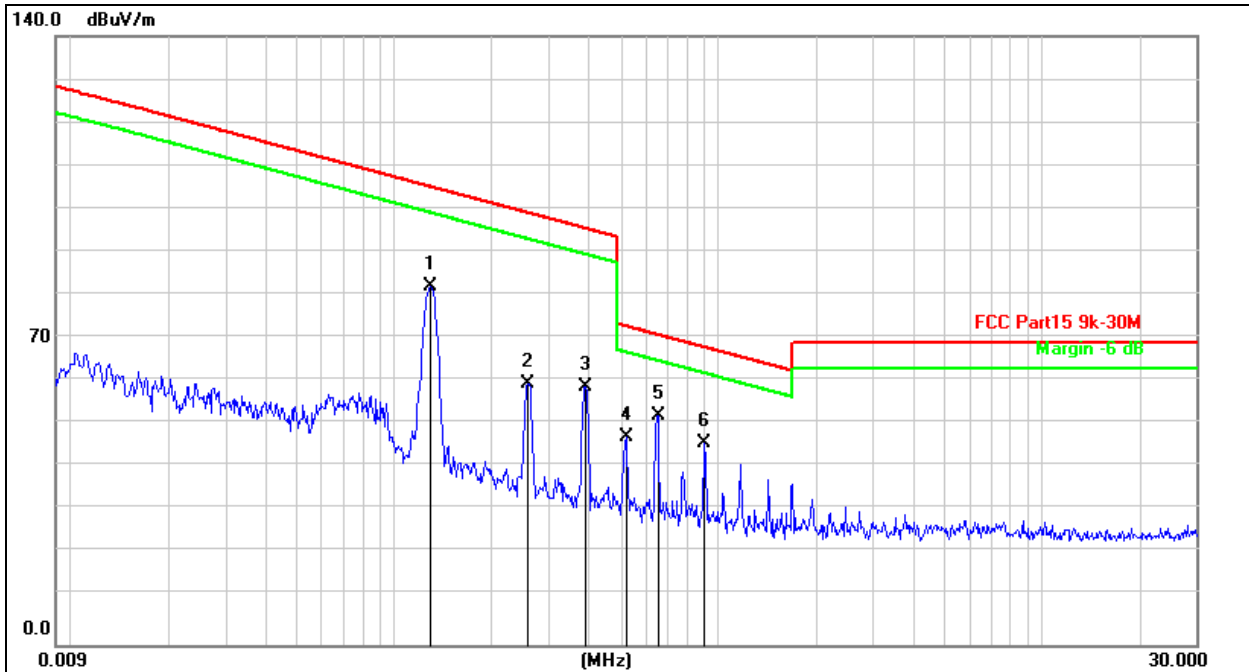
Remark:

1. Factor = Antenna Factor + Cable Loss – Pre-amplifier.
2. Measurement=Reading Level+ Correct Factor
3. Over=Measurement-Limit

No.	Mk.	Freq. MHz	Reading Level dBuV	Correct Factor dB	Measure- ment dBuV/m	Limit dB/m	Over dB	Detector
1		0.1298	89.90	-7.54	82.36	105.3	-22.98	peak
2		0.2587	67.61	-7.74	59.87	99.35	-39.48	peak
3		0.3912	67.13	-7.65	59.48	95.76	-36.28	peak
4		0.5196	55.42	-7.55	47.87	73.29	-25.42	peak
5	*	0.6521	60.06	-7.41	52.65	71.32	-18.67	peak
6		0.9094	53.69	-7.36	46.33	68.44	-22.11	peak

Note: The worst DC voltage mode is Mode6.

Between 30MHz – 1GHz

Temperature:	26°C	Relative Humidity:	54%
Pressure:	101 kPa	Test Voltage :	AC 120V/60Hz
Test Mode :	Mode 2	Polarization :	Horizontal

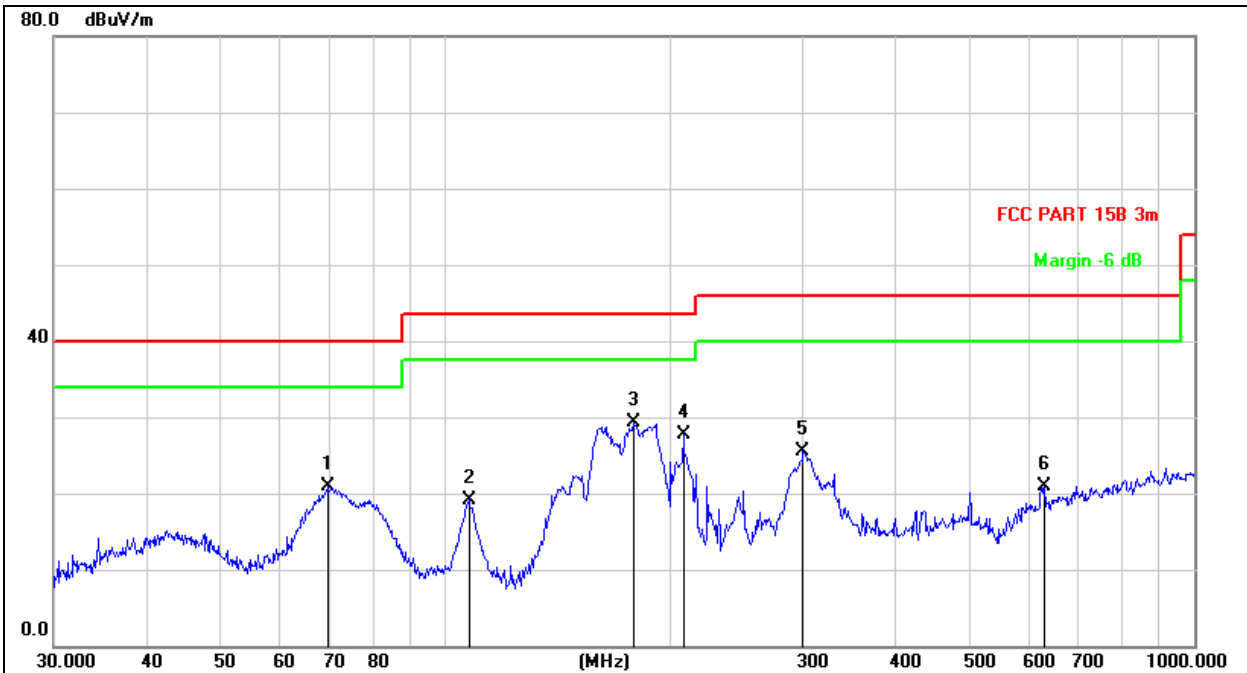

Remark:

1. Factor = Antenna Factor + Cable Loss – Pre-amplifier.
2. Measurement=Reading Level+ Correct Factor
3. Over=Measurement-Limit

No.	Mk.	Freq. MHz	Reading Level dBuV	Correct Factor dB	Measure- ment dBuV/m	Limit dB/m	Over dB	Detector
1		69.6005	38.71	-17.89	20.82	40.00	-19.18	QP
2		107.5101	35.58	-16.46	19.12	43.50	-24.38	QP
3	*	178.1327	46.55	-17.34	29.21	43.50	-14.29	QP
4		207.8501	43.27	-15.50	27.77	43.50	-15.73	QP
5		300.3672	38.79	-13.23	25.56	46.00	-20.44	QP
6		631.6884	27.35	-6.47	20.88	46.00	-25.12	QP

Temperature:	26°C	Relative Humidity:	54%
Pressure:	101 kpa	Test Voltage :	AC 120V/60Hz
Test Mode :	Mode 2	Polarization :	Vertical

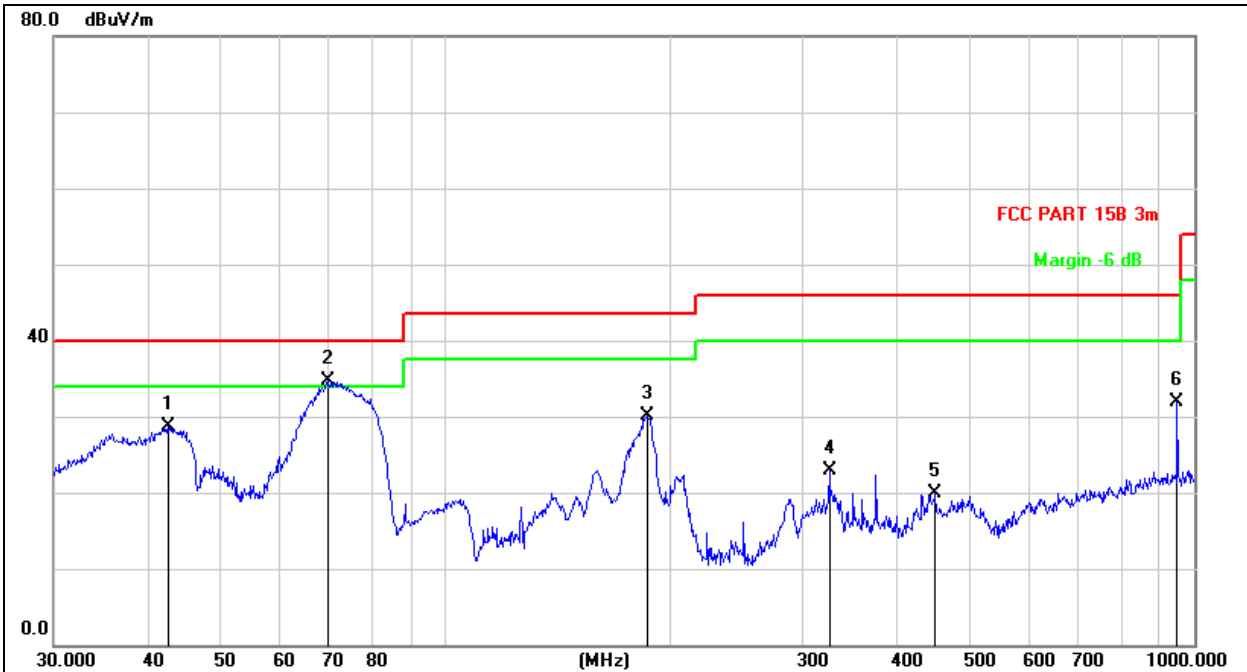
Remark:

1. Factor = Antenna Factor + Cable Loss – Pre-amplifier.
2. Measurement=Reading Level+ Correct Factor
3. Over=Measurement-Limit

No.	Mk.	Freq. MHz	Reading Level dBuV	Correct Factor dB	Measure- ment dBuV/m	Limit dB/m	Over dB	Detector
1		42.6000	43.25	-14.51	28.74	40.00	-11.26	QP
2	*	69.6005	52.68	-17.89	34.79	40.00	-5.21	QP
3		186.4409	46.78	-16.73	30.05	43.50	-13.45	QP
4		325.5958	35.21	-12.34	22.87	46.00	-23.13	QP
5		451.1350	29.68	-9.83	19.85	46.00	-26.15	QP
6		948.7610	34.88	-2.94	31.94	46.00	-14.06	QP

Note: The worst AC voltage mode is Mode2.

Between 30MHz – 1GHz

Temperature:	26°C	Relative Humidity:	54%
Pressure:	101 kPa	Test Voltage :	DC 3.7V
Test Mode :	Mode 6	Polarization :	Horizontal

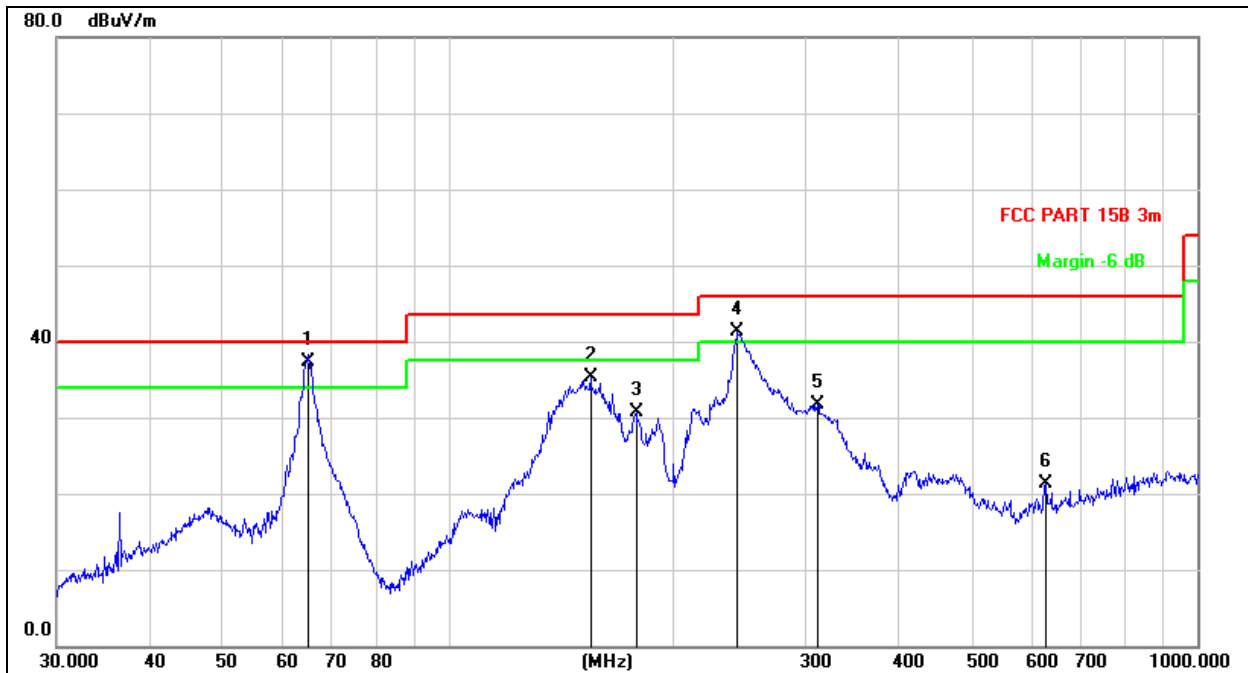

Remark:

1. Factor = Antenna Factor + Cable Loss – Pre-amplifier.
2. Measurement=Reading Level+ Correct Factor
3. Over=Measurement-Limit

No.	Mk.	Freq. MHz	Reading Level dBuV	Correct Factor dB	Measure- ment dBuV/m	Limit dB/m	Over dB	Detector
1	*	64.8545	53.84	-16.58	37.26	40.00	-2.74	QP
2		154.8204	54.45	-19.07	35.38	43.50	-8.12	QP
3		178.1327	48.01	-17.34	30.67	43.50	-12.83	QP
4	!	243.3772	55.81	-14.48	41.33	46.00	-4.67	QP
5		311.0867	44.61	-12.85	31.76	46.00	-14.24	QP
6		627.2738	27.78	-6.55	21.23	46.00	-24.77	QP

Temperature:	26°C	Relative Humidity:	54%
Pressure:	101 kpa	Test Voltage :	DC 3.7V
Test Mode :	Mode 6	Polarization :	Vertical

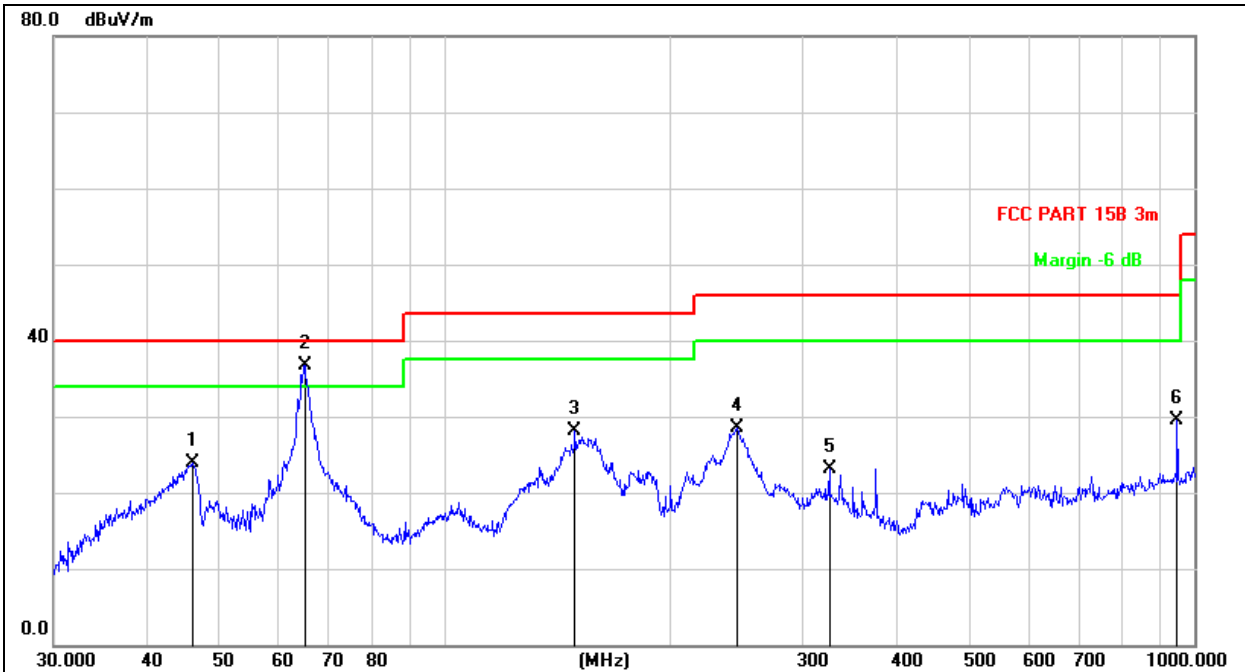
Remark:

1. Factor = Antenna Factor + Cable Loss – Pre-amplifier.
2. Measurement = Reading Level + Correct Factor
3. Over = Measurement - Limit

No.	Mk.	Freq. MHz	Reading Level dBuV	Correct Factor dB	Measure- ment dBuV/m	Limit dB/m	Over dB	Detector
1		46.0164	38.10	-14.23	23.87	40.00	-16.13	QP
2	*	64.8865	53.38	-16.59	36.79	40.00	-3.21	QP
3		148.9625	47.41	-19.36	28.05	43.50	-15.45	QP
4		245.0900	42.84	-14.43	28.41	46.00	-17.59	QP
5		325.5958	35.44	-12.34	23.10	46.00	-22.90	QP
6		948.7610	32.43	-2.94	29.49	46.00	-16.51	QP

Note: The worst DC voltage mode is Mode6.

8. Bandwidth Test

8.1 Test Setup



8.2 Test Procedure

1. Set RBW = 1%~5% OBW.
2. Set the video bandwidth (VBW) $\geq 3 \times$ RBW.
3. Detector = Peak.
4. Trace mode = max hold.
5. Sweep = auto couple.
6. Allow the trace to stabilize.
7. Measure the maximum width of the emission that is constrained by the frequencies associated with the two outermost amplitude points (upper and lower frequencies) that are attenuated by 20 dB relative to the maximum level measured in the fundamental emission.

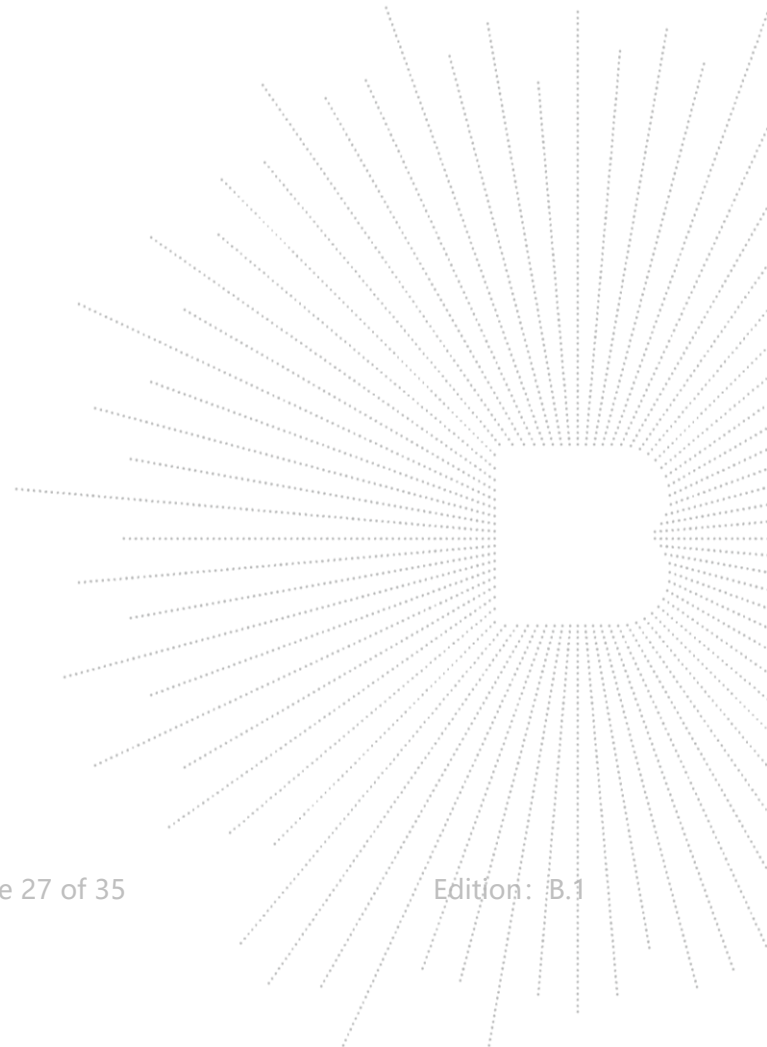

8.3 Test Result

Temperature:	26 °C	Relative Humidity:	54%
Pressure:	101kPa		

Frequency (KHz)	20dB bandwidth (Hz)	Result
127.5	391	Pass



9. Antenna Requirements

For intentional device, according to FCC 47 CFR Section 15.203, An intentional radiator shall be designed to ensure that no antenna other than that furnished by the responsible party shall be used with the device. The use of a permanently attached antenna or of an antenna that uses a unique coupling to the intentional radiator shall be considered sufficient to comply with the provisions of this section. The manufacturer may design the unit so that a broken antenna can be replaced by the user, but the use of a standard antenna jack or electrical connector is prohibited. The antenna used for this product is Inductive loop coil antenna.

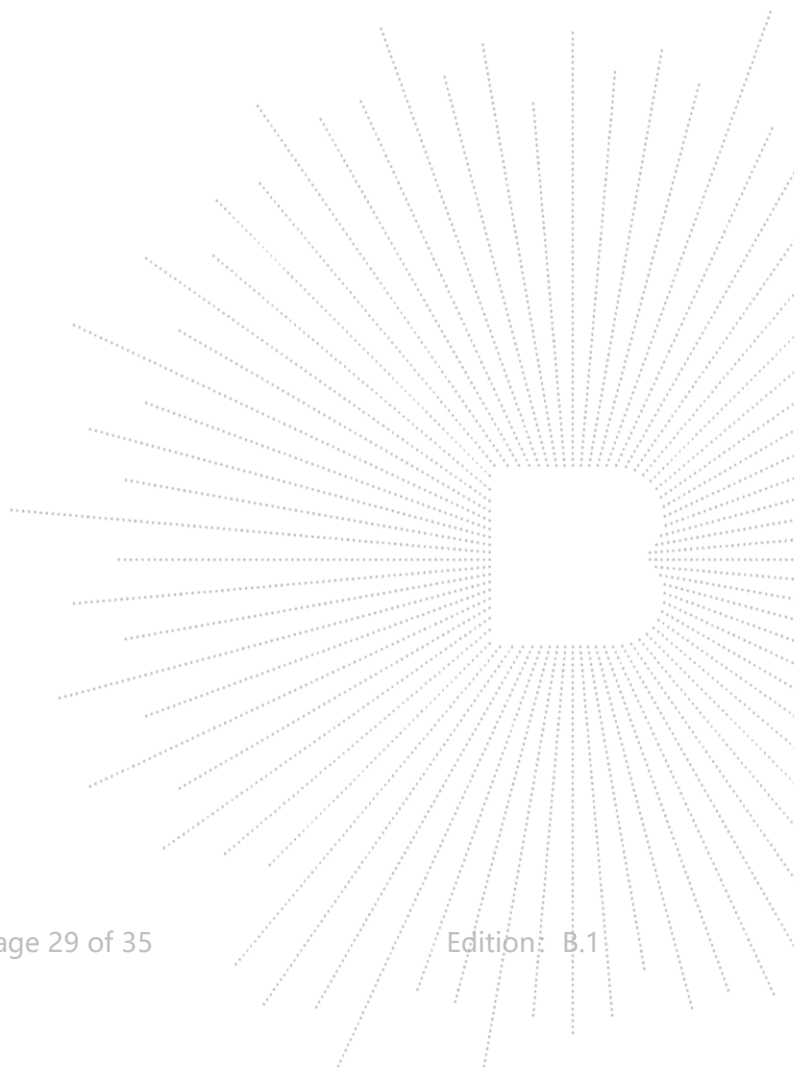

10. EUT Photographs

EUT Photo 1

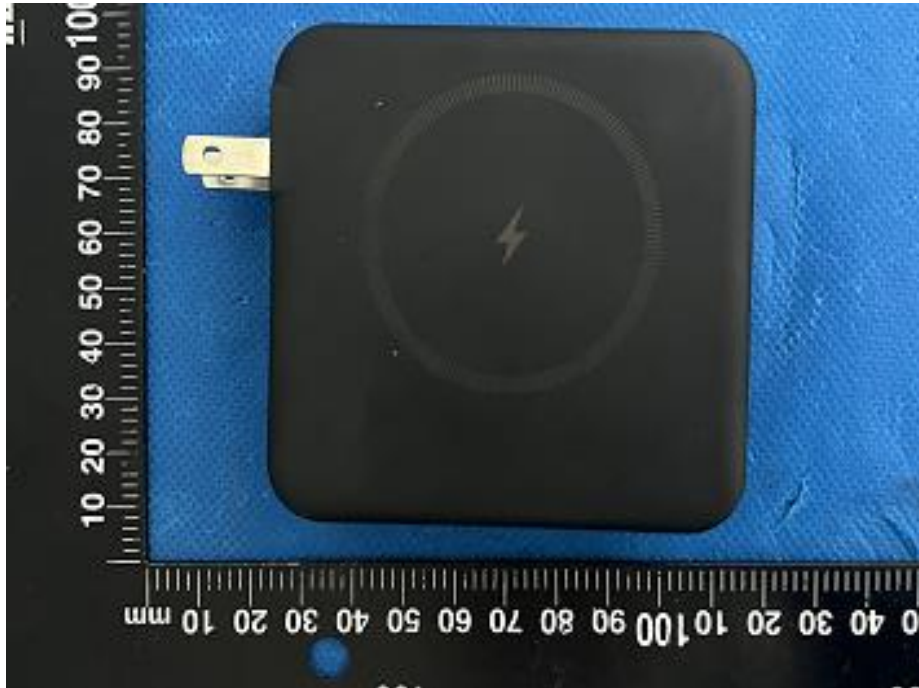

EUT Photo 2

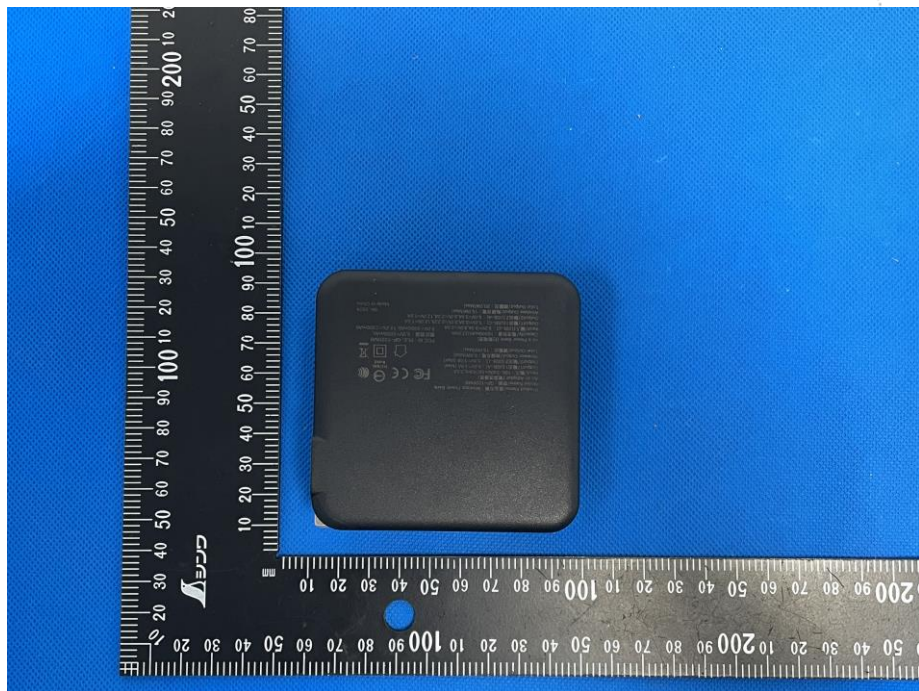

NOTE: Appendix-Photographs Of EUT Constructional Details

11. EUT Test Setup Photographs

Conducted Emissions Photo



Radiated Measurement Photos (AC Mode)

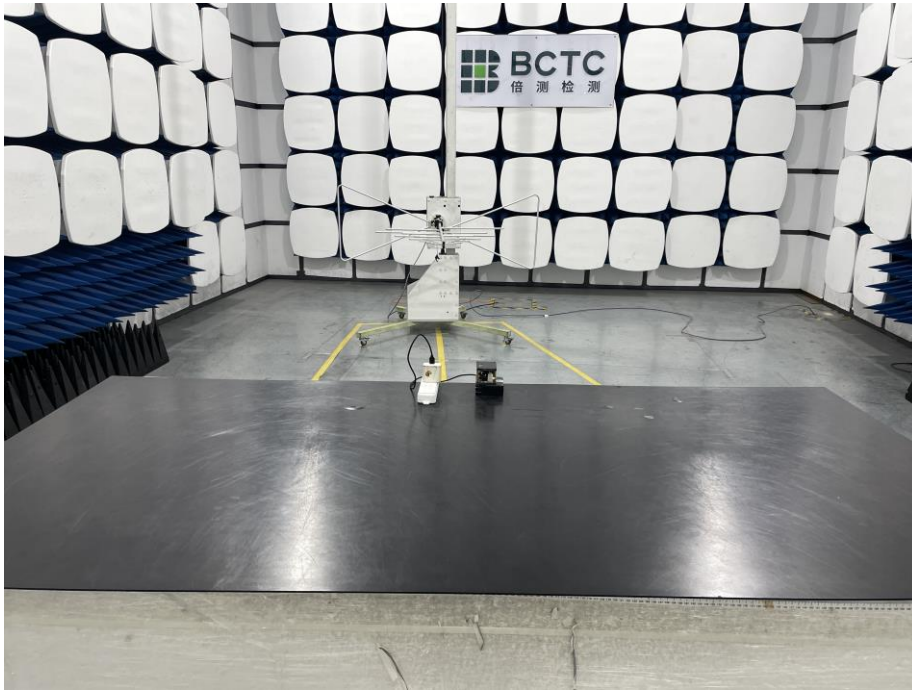

(AC Mode)

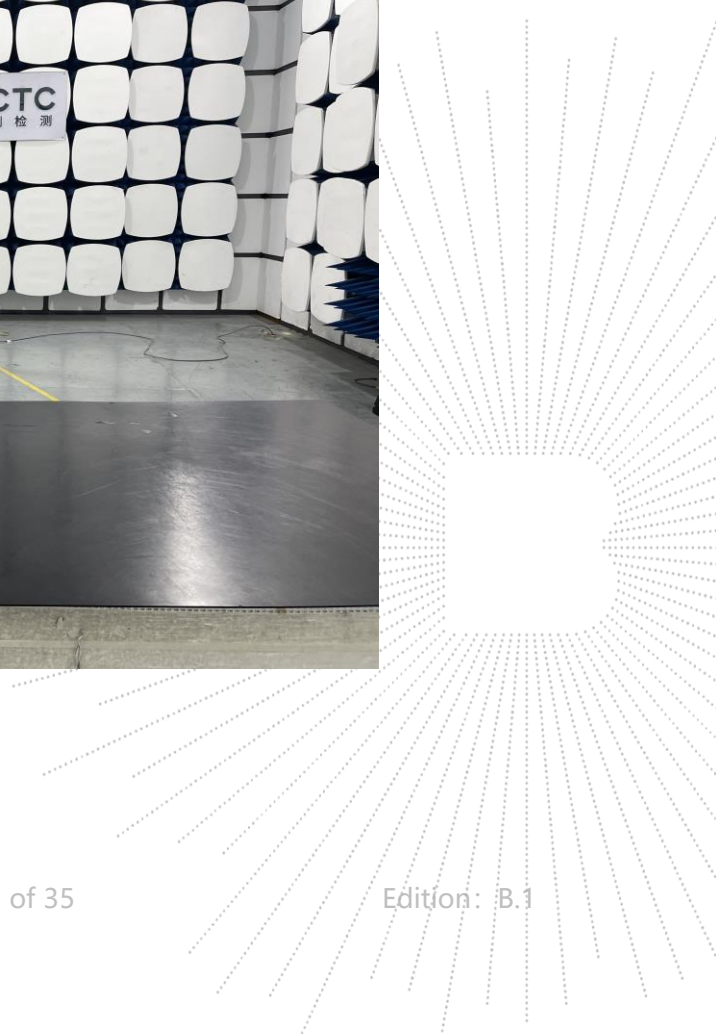
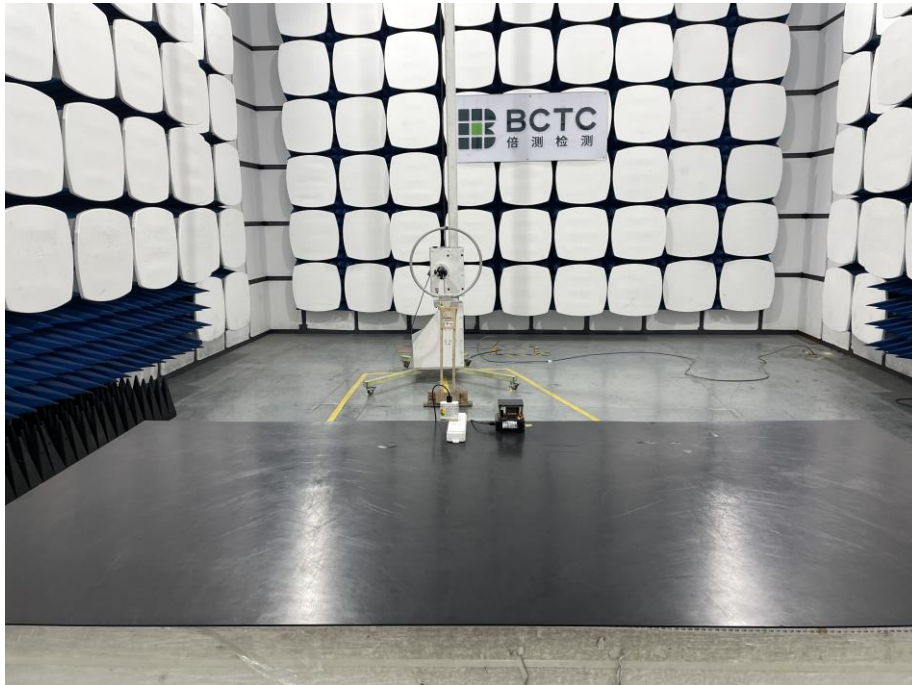

(DC Mode)

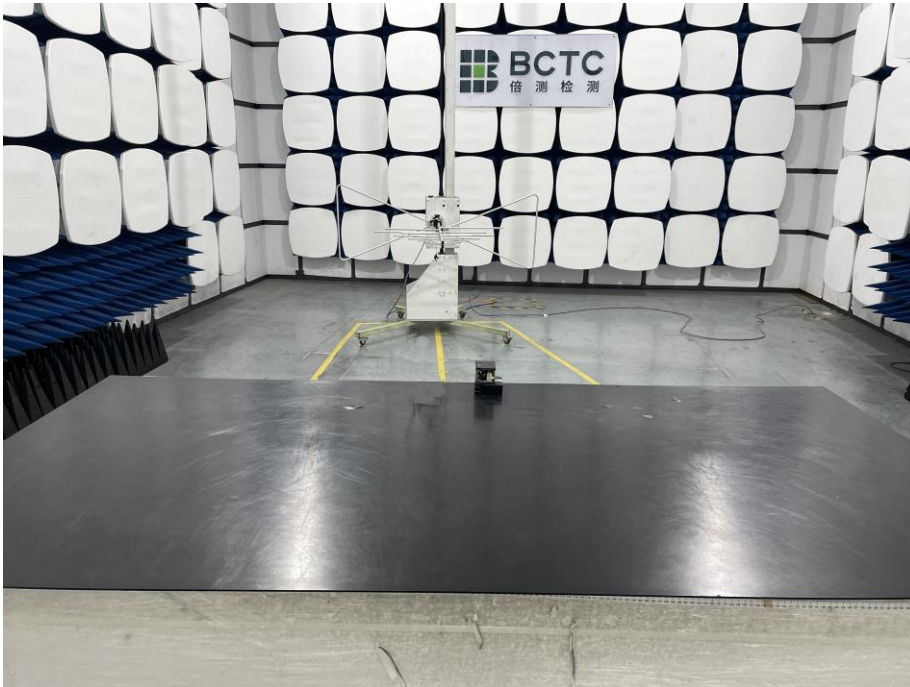

(DC Mode)

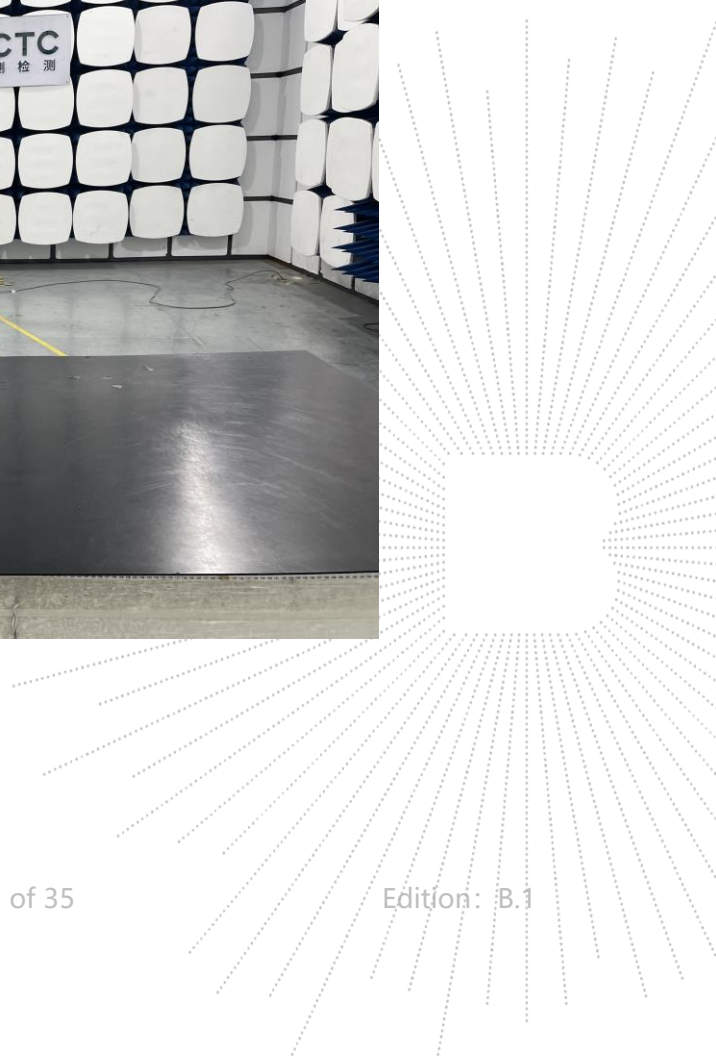
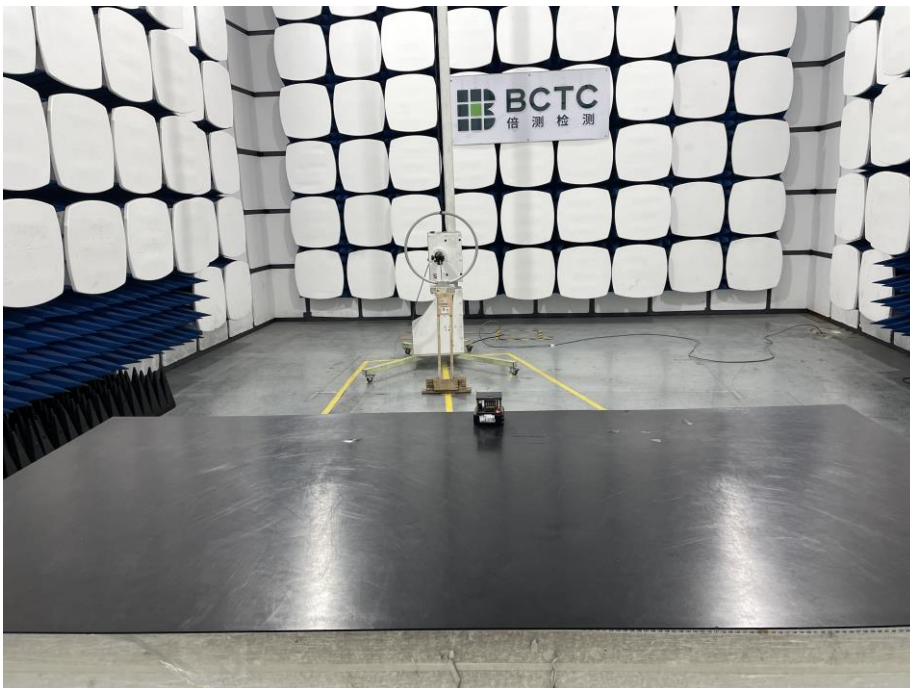

(AC Mode)

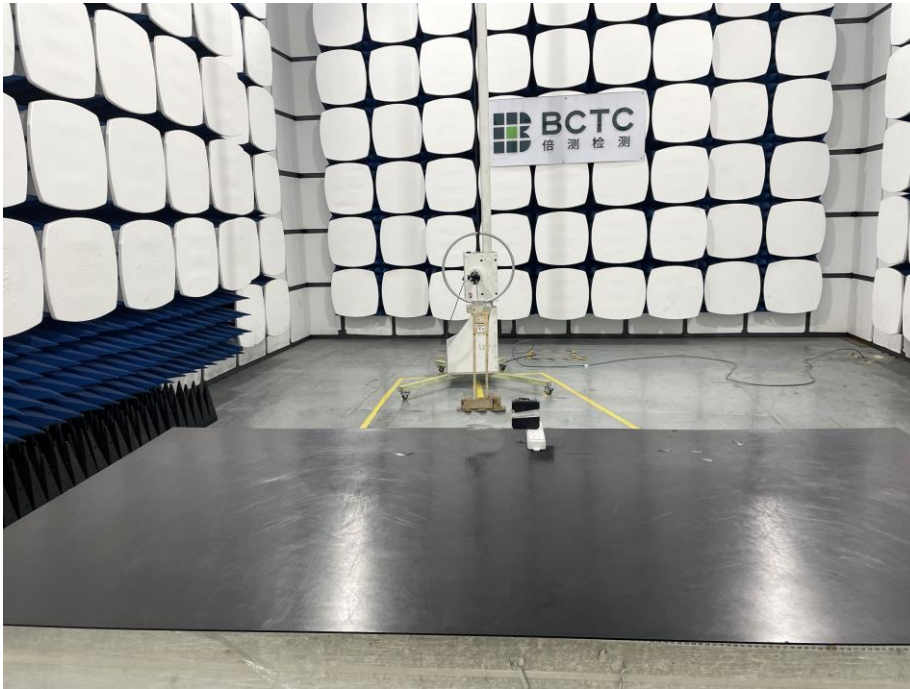

(AC Mode)

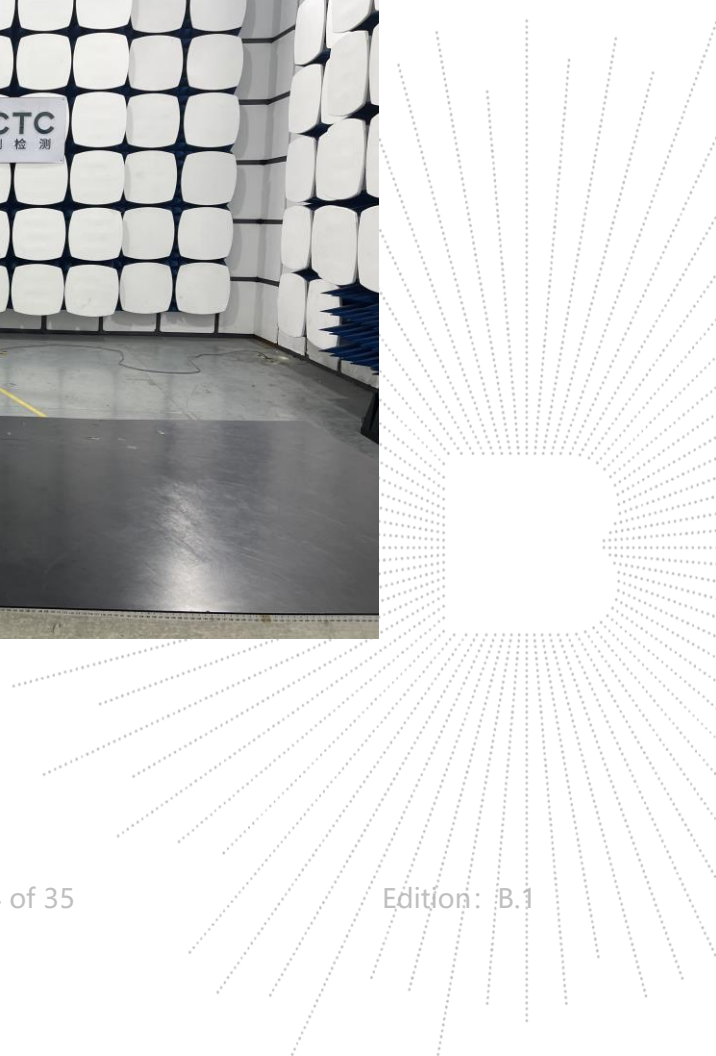
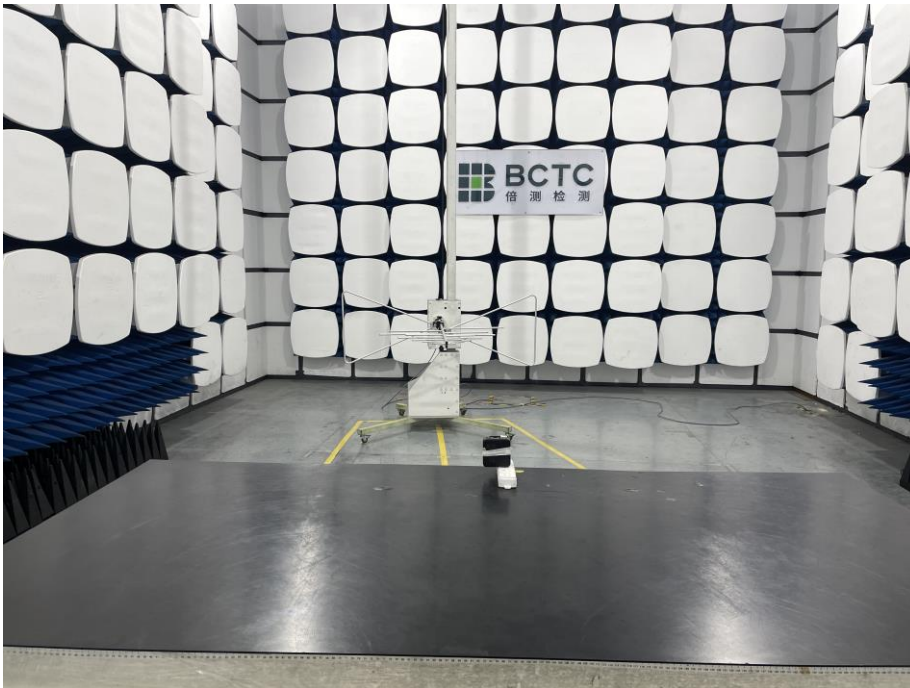

STATEMENT

1. The equipment lists are traceable to the national reference standards.
2. The test report can not be partially copied unless prior written approval is issued from our lab.
3. The test report is invalid without the "special seal for inspection and testing".
4. The test report is invalid without the signature of the approver.
5. The test process and test result is only related to the Unit Under Test.
6. Sample information is provided by the client and the laboratory is not responsible for its authenticity.
7. The quality system of our laboratory is in accordance with ISO/IEC17025.
8. If there is any objection to this test report, the client should inform issuing laboratory within 15 days from the date of receiving test report.

Address:

1-2/F., Building B, Pengzhou Industrial Park, No.158, Fuyuan 1st Road, Zhancheng, Fuhai Subdistrict, Bao'an District, Shenzhen, Guangdong, China

TEL: 400-788-9558

P.C.: 518103

FAX: 0755-33229357

Website: <http://www.chnbctc.com>E-Mail: bctc@bctc-lab.com.cn

※※※※※ END ※※※※※

