





Test report No: 2420117R-0E3012110014-A

FCC TEST REPORT

Product Name	Peplink Pepwave Wireless Product
Trademark	
Model and /or type reference	MAX BR2 BR2 MAX-BR2-LTE-US-T-PRM
FCC ID	U8G-P1MT03A
Applicant's name / address	PISMO LABS TECHNOLOGY LIMITED A8, 5/F, HK Spinners Industrial Building, Phase 6, 481 Castle Peak Road, Cheung Sha Wan, Hong Kong
Manufacturer's name / address	PISMO LABS TECHNOLOGY LIMITED A8, 5/F, HK Spinners Industrial Building, Phase 6, 481 Castle Peak Road, Cheung Sha Wan, Hong Kong
Test method requested, standard	FCC CFR Title 47 Part 15 Subpart B:2022, Class A
Verdict Summary	IN COMPLIANCE
Documented By (Senior Adm. Specialist / Anny Chou)	
Approved By (Director / Vincent Lin)	
Date of Report	2024/02/05
Date of Issue	2024/03/25
Report No.	2420117R-0E3012110014-A
Report Version	V1.0

INDEX

Description	Page
1. General Information	5
1.1. EUT Description.....	5
1.2. Mode of Operation	6
1.3. Configuration & Details of Tested System	7
1.4. EUT Exercise Software.....	8
2. Technical Test.....	9
2.1. Summary of Test Result.....	9
2.2. List of Test Equipment	10
2.3. Measurement Uncertainty.....	11
2.4. Test Environment	12
3. Conducted Emission	13
3.1. Test Specifications	13
3.2. Test Setup.....	13
3.3. Limit	13
3.4. Test Procedure.....	14
3.5. Test Result.....	15
4. Radiated Emission	17
4.1. Test Specification.....	17
4.2. Test Setup.....	17
4.3. Limit	18
4.4. Test Procedure.....	19
4.5. Test Result.....	20

Product Photos: Please refer to the file: 2420117R-Product Photos

Competences and Guarantees

DEKRA is a testing laboratory competent to carry out the tests described in this report.

In order to assure the traceability to other national and international laboratories, DEKRA has a calibration and maintenance program for its measurement equipment.

DEKRA guarantees the reliability of the data presented in this report, which is the result of the measurements and the tests performed to the item under test on the date and under the conditions stated in the report and it is based on the knowledge and technical facilities available at DEKRA at the time of performance of the test.

DEKRA is liable to the client for the maintenance of the confidentiality of all information related to the item under test and the results of the test.

The results presented in this Test Report apply only to the particular item under test established in this document.

IMPORTANT: No parts of this report may be reproduced or quoted out of context, in any form or by any means, except in full, without the previous written permission of DEKRA.

General conditions

1. The test results relate only to the samples tested.
2. The test results shown in the test report are traceable to the national/international standard through the calibration report of the equipment and evaluated measurement uncertainty herein.
3. This report must not be used to claim product endorsement by TAF or any agency of the government.
4. The test report shall not be reproduced without the written approval of DEKRA Testing and Certification Co., Ltd.
5. Measurement uncertainties evaluated for each testing system and associated connections are given here to provide the system information for reference. Compliance determinations do not take into account measurement uncertainties for each testing system, but are based on the results of the compliance measurement.

Revision History

Report No.	Version	Description	Issued Date
2420117R-0E3012110014-A	V1.0	Initial issue of report.	2024-03-25

1. General Information

1.1. EUT Description

Product Name	Peplink Pepwave Wireless Product
Trademark	
Model No.	MAX BR2 BR2 MAX-BR2-LTE-US-T-PRM
EUT Max. Frequency	5850 MHz
EUT Rated Voltage	DC 10-30V 802.3at PoE
EUT Test Voltage (Final Test Mode)	AC 120V/60Hz to DC 12V (AC Adapter) DC 10V

Component	
Adapter	MFR: DVE M/N: DSA-36PFN-12 FUS 120300 AC Input: 100-240Vac, 50/60Hz, 1.0A DC Output: 12.0V, 3.0A, 36.0W Cable Out: Non-Shielded, 1.5m
WLAN Antenna	MFR: YUAN CHEN TECH CO., LTD M/N: ACA-0040-6G1A1-A10 Antenna Type: Omni-directional
GPS Antenna	Brand: INPAQ M/N: DAM-D13-S1-N0-000-08-20 Antenna Type: Directional
Cellular Antenna	Brand: Master Wave M/N: 98335KSAF000 Antenna Type: Omni-directional

Note: The EUT is including three models for different marketing requirement.

1.2. Mode of Operation

DEKRA has verified the construction and function in typical operation. All the test modes were carried out with the EUT in normal operation, which was shown in this test report and defined as:

Pre-Test Mode (Conducted Emission)	
Mode 1:	Normal Operation(LAN 1Gbps + WAN 1Gbps + GPS + USB + Wi-Fi 2.4G + Wi-Fi 5G + WWAN LTE Band 2 Link + SIM Card-Slot A-2), Molex Power Port, DC 12V By Adapter(DVE/DSA-36PFN-12 FUS 120300)
Mode 2:	Normal Operation(LAN 1Gbps + WAN 1Gbps + GPS + USB + Wi-Fi 2.4G + Wi-Fi 5G + WWAN LTE Band 2 Link + SIM Card-Slot A-2), 802.3at PoE
Mode 3:	Normal Operation(LAN 1Gbps + WAN 1Gbps + GPS + USB + Wi-Fi 2.4G + Wi-Fi 5G + WWAN WCDMA Band 2 Link + SIM Card-Slot A-2), Molex Power Port, DC 12V By Adapter(DVE/DSA-36PFN-12 FUS 120300)
Pre-Test Mode (Radiated Emission)	
Mode 1:	Normal Operation(LAN 1Gbps + WAN 1Gbps + GPS + USB + Wi-Fi 2.4G + Wi-Fi 5G + WWAN LTE Band 2 Link + SIM Card-Slot A-2), Molex Power Port, DC 12V By Adapter(DVE/DSA-36PFN-12 FUS 120300)
Mode 2:	Normal Operation(LAN 1Gbps + WAN 1Gbps + GPS + USB + Wi-Fi 2.4G + Wi-Fi 5G + WWAN LTE Band 2 Link + SIM Card-Slot A-2), Molex Power Port, DC 10V
Mode 3:	Normal Operation(LAN 1Gbps + WAN 1Gbps + GPS + USB + Wi-Fi 2.4G + Wi-Fi 5G + WWAN LTE Band 2 Link + SIM Card-Slot A-2), Molex Power Port, DC 30V
Mode 4:	Normal Operation(LAN 1Gbps + WAN 1Gbps + GPS + USB + Wi-Fi 2.4G + Wi-Fi 5G + WWAN LTE Band 2 Link + SIM Card-Slot A-2), Terminal Block Port, DC 10V
Mode 5:	Normal Operation(LAN 1Gbps + WAN 1Gbps + GPS + USB + Wi-Fi 2.4G + Wi-Fi 5G + WWAN LTE Band 2 Link + SIM Card-Slot A-2), Terminal Block Port, DC 30V
Mode 6:	Normal Operation(LAN 1Gbps + WAN 1Gbps + GPS + USB + Wi-Fi 2.4G + Wi-Fi 5G + WWAN LTE Band 2 Link + SIM Card-Slot A-2), 802.3at PoE
Mode 7:	Normal Operation(LAN 1Gbps + WAN 1Gbps + GPS + USB + Wi-Fi 2.4G + Wi-Fi 5G + WWAN WCDMA Band 2 Link + SIM Card-Slot A-2), Molex Power Port, DC 10V
Final Test Mode	
Conducted Emission	Mode 1
Radiated Emission	Mode 2

Note:

1. Refer to Certified Cellular module report worst band to test.
2. This product supports client/master mode, but it does not affect EMC testing after evaluation.

1.3. Configuration & Details of Tested System

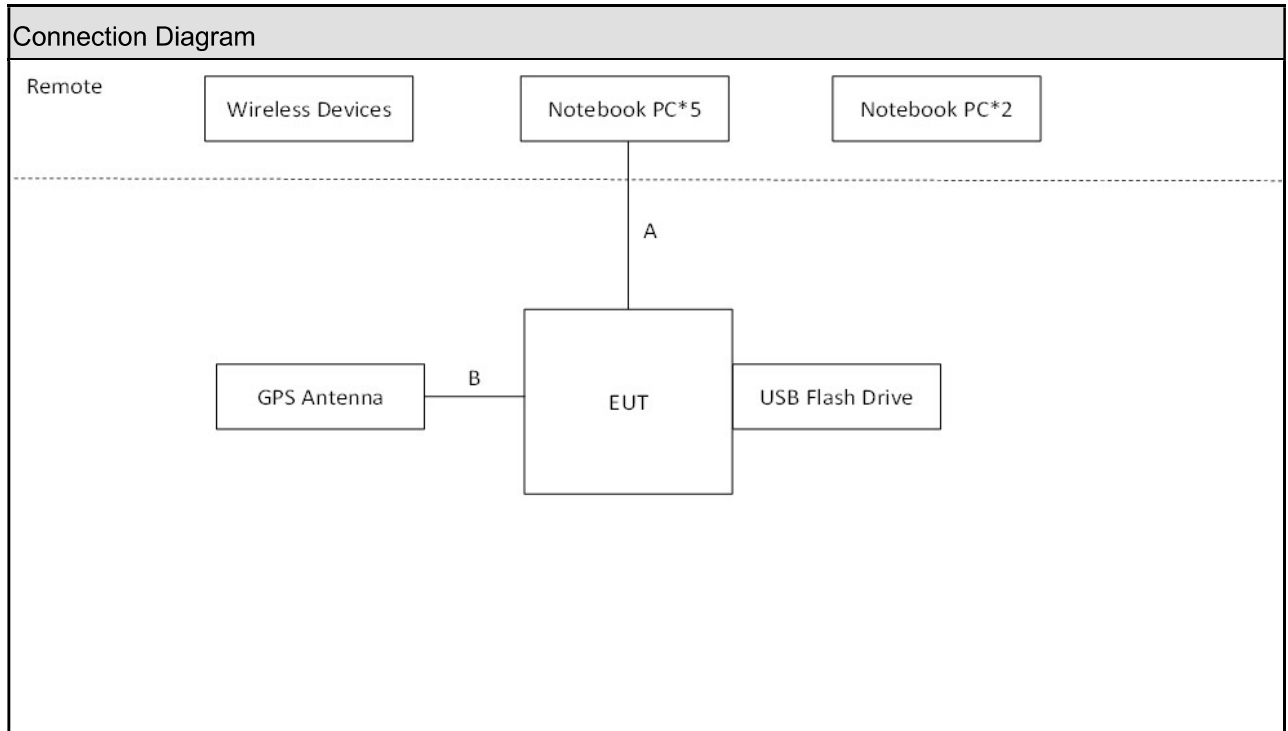

Tested System Details

Product	Manufacturer	Model No.	No.	Cable Type & Description
Notebook PC *7	Lenovo	IdeaPad 3 14ALC6	A	LAN *5, non-shielded 10m
USB Flash Drive	Transcend	JetFlash 890		
GPS Antenna	N/A	N/A	B	SMA, shielded 5m

Wireless Devices Inf.

Product	Manufacturer	Model No.
GPS Simulator	Orolia	GSG-5
UXM 5G Wireless Test Platform	Keysight	E7515B

Note:

- Use Full system setup configuration determines Worst-Case Mode.
- Use 2dB law program determines Max. Cable Configuration and Worst-Case Mode.
- Radiated emission item test: Performed using the Horn Antenna 3dB Beamwidth to 3m from the EUT size sufficient to cover the procedure.
- Radiated emission item test: Performed using the Horn Antenna 3dB Beamwidth non 3m distance sufficient to cover the size of the EUT program.

1.4. EUT Exercise Software

1	Setup the EUT and simulators as shown on 1.3.
2	Turn on the power of all equipments.
3	All the features of the EUT operation normally.

2. Technical Test

2.1. Summary of Test Result

- No deviations from the test standards
 Deviations from the test standards as below description:

Emission				
Performed Item	Normative References	Test Performed	Test Site	Verdict
Conducted Emission	FCC CFR Title 47 Part 15 Subpart B:2022, Class A CISPR 22:2008, ANSI C63.4-2014 ANSI C63.4a-2017	Yes	HY-SR09	Pass
Radiated Emission	FCC CFR Title 47 Part 15 Subpart B:2022, Class A CISPR 22:2008, ANSI C63.4-2014 ANSI C63.4a-2017	Yes	FS-CB01 HY-CB05	Pass

Note:

1. Test Site information refers to test Laboratory Information.

Test Laboratory:	DEKRA Testing and Certification Co., Ltd. Linkou Laboratory
Address:	No.5-22, Ruishukeng Linkou District, New Taipei City, 24451, Taiwan, R.O.C
Phone number:	+886-2-8601-3788
Fax number:	+886-2-8601-3789
Test Site	
LK:	No.5-22, Ruishukeng Linkou District, New Taipei City, 24451, Taiwan, R.O.C
FS:	No.6, Lane 75, Wenlin St., Linkou Dist., New Taipei City, 244017, Taiwan, R.O.C No. 85, Wenlin St., Linkou Dist., New Taipei City, 244017, Taiwan, R.O.C
HY:	No.26, Huaya 1 st Rd., Guishan Dist., Taoyuan City 333411, Taiwan, R.O.C

2.2. List of Test Equipment

Conducted Emission / HY-SR09

Instrument	Manufacturer	Type No.	Serial No.	Cal. Date	Due Date
EMI TEST RECEIVER	R&S	ESR3	102917	2023/12/4	2024/12/3
Two-Line V-Network	R&S	ENV216	101493	2023/12/1	2024/11/30
Two-Line V-Network	R&S	ENV216	101492	2023/12/12	2024/12/11
Impedance Stabilization Network	TESEQ	ISN T800	61676	2023/6/17	2024/6/16
Impedance Stabilization Network	TESEQ	ISN T8-Cat6	61286	2023/6/15	2024/6/14
Impedance Stabilization Network	TESEQ	ISN ST08	61833	2023/6/19	2024/6/18
Coaxial Cable	SUHNER	RG 400	HC001-RG	2023/5/31	2024/5/30
Note : ISN T800 for LAN 10Mbps to 1Gbps, T8-Cat6 for LAN above 1Gbps, ST08 for Shielded LAN					
Test Software version : e3 V9					

Note: Test Receiver Detector: Quasipeak and Average Bandwidth:9kHz

Radiated Emission (Below 1GHz) / FS-CB01

Instrument	Manufacturer	Type No.	Serial No.	Cal. Date	Due Date
Trilog-Broadband Antenna	Schwarzbeck	VULB 9168	01124	2023/9/18	2024/9/17
Trilog-Broadband Antenna	Schwarzbeck	VULB 9168	01126	2023/9/18	2024/9/17
Receiver	R&S	ESR7	102255	2023/3/27	2024/3/26
Receiver	R&S	ESR7	102254	2023/12/7	2024/12/6
Coaxial Cable	SUHNER	SUCOFLEX 106	AC043-SF	2023/7/7	2024/7/6
Coaxial Cable	SUHNER	SUCOFLEX 106	AC044-SF	2023/7/7	2024/7/6
Coaxial Cable	SUHNER	SUCOFLEX 106	AC045-SF	2023/7/7	2024/7/6
Coaxial Cable	SUHNER	SUCOFLEX 106	AC046-SF	2023/7/7	2024/7/6
Coaxial Cable	SUHNER	SUCOFLEX 106	AC047-SF	2023/7/7	2024/7/6
Coaxial Cable	SUHNER	SUCOFLEX 106	AC049-SF	2023/7/7	2024/7/6
Coaxial Cable	SUHNER	SUCOFLEX 106	AC051-SF	2023/7/7	2024/7/6
Coaxial Cable	SUHNER	SUCOFLEX 106	AC052-SF	2023/7/7	2024/7/6
Preamplifier	SGH	EM330	20200921-5	2023/6/19	2024/6/18
Preamplifier	SGH	EM330	20200921-6	2023/6/19	2024/6/18
NSA	DEKRA	N/A	N/A	2023/7/8	2024/7/7
Test Software version : e3 V9					

Note: Test Receiver Detector: Quasipeak Bandwidth:120kHz

Radiated Emission (Above 1GHz) / HY-CB05

Instrument	Manufacturer	Type No.	Serial No.	Cal. Date	Due Date
Double Ridged Guide Horn Antenna	RF SPIN	DRH18-E	210504A18ES	2023/5/26	2024/5/25
Horn Antenna	COM-POWER	AH-840	101088	2023/10/4	2024/10/3
EMI Test Receiver	R&S	ESR7	102502	2023/3/28	2024/3/27
Signal Analyzer	R&S	FSV3044	101245	2023/4/17	2024/4/16
Coaxial Cable	ROSNOL	R-Test EW0630	HC003R	2023/6/19	2024/6/18
Coaxial Cable	ROSNOL	R-Test EW0630	HC005R	2023/6/19	2024/6/18
Coaxial Cable	ROSNOL	R-Test EW0630	HC004R	2023/6/19	2024/6/18
Preamplifier	SGH	SGH118-HS	20220411-2	2023/4/26	2024/4/25
Microwave Preamplifier with cable	SGH	SGH184	20220411-3	2023/4/26	2024/4/25
VSWR	DEKRA	N/A	N/A	2023/8/23	2024/8/22
Test Software version : e3 V9					

2.3. Measurement Uncertainty

Test Items	Uncertainty
Conducted Emission	± 2.40 dB
Radiated Emission (Below 1GHz)	± 5.50 dB
Radiated Emission (Above 1GHz)	± 4.70 dB

2.4. Test Environment

Performed Item	Items	Required
Conducted Emission	Temperature (°C)	10-40
	Humidity (%RH)	10-90
Radiated Emission	Temperature (°C)	10-40
	Humidity (%RH)	10-90

3. Conducted Emission

3.1. Test Specifications

According to Standard : FCC Part 15 Subpart B & CISPR 22

3.2. Test Setup

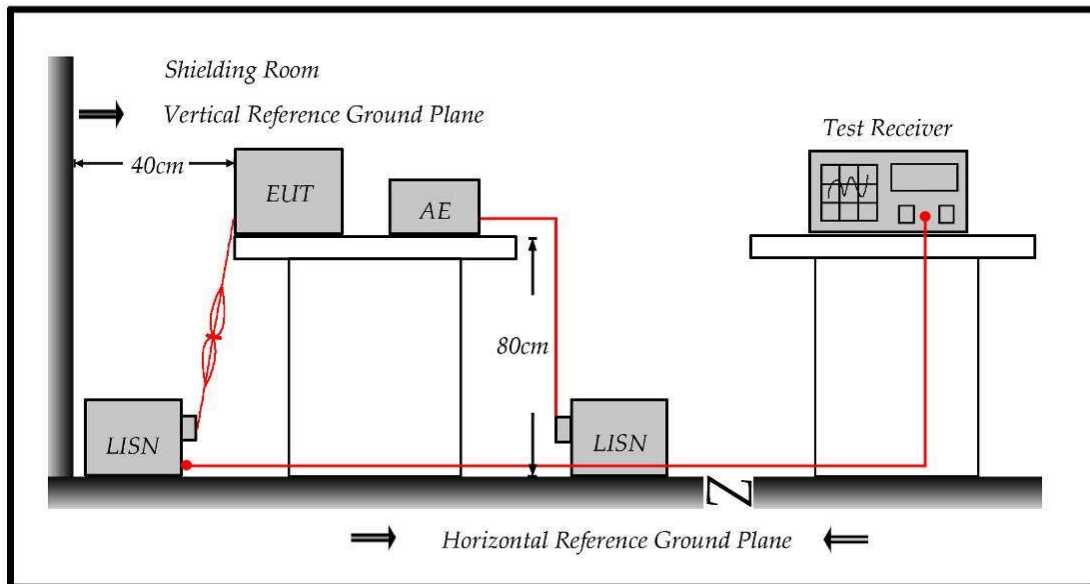

3.3. Limit

Conducted emissions limits (AC mains power terminals)				
Frequency range (MHz)	Class A Quasi-peak (dBuV)	Class A Average (dBuV)	Class B Quasi-peak (dBuV)	Class B Average (dBuV)
0.15 - 0.5	79	66	66 to 56	56 to 46
0.5 - 5	73	60	56	46
5 - 30	73	60	60	50

Note:

1. The more stringent limit applies at transition frequencies.
2. The limit level in dB μ V decreases linearly with the logarithm of frequency

3.4. Test Procedure

The EUT and simulators are connected to the main power through a line impedance stabilization network (L.I.S.N.). This provides a 50ohm/50uH coupling impedance for the measuring equipment. The peripheral devices are also connected to the main power through a LISN that provides a 50ohm/50uH coupling impedance with 50ohm termination.

(Please refers to the block diagram of the test setup and photographs.)

Both sides of A.C. line are checked for maximum conducted interference. In order to find the maximum emission, the relative positions of equipment and all of the interface cables must be changed on conducted measurement.

Conducted emissions were invested over the frequency range from 0.15MHz to 30MHz using a receiver bandwidth of 9kHz.

3.5. Test Result

Model No	MAX BR2	Site	HY-SR09
Test Voltage	AC 120V/60Hz	Test Date	2024-03-13
Test Mode	Mode 1	Engineer	Monica Wu
Phase	Line	Temperature (°C)	19
Test Condition	--	Humidity (%RH)	50

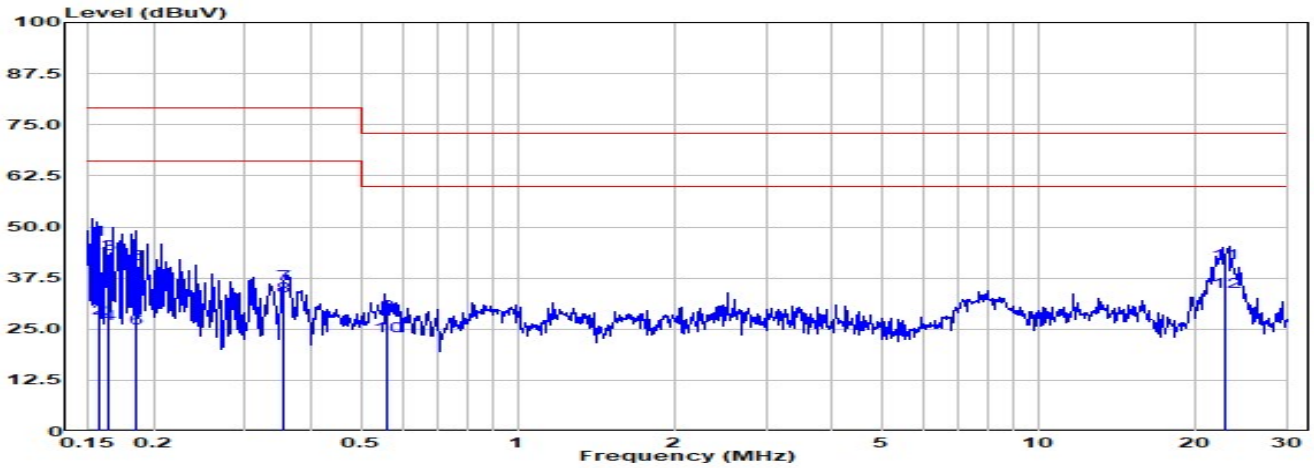

No	Frequency (MHz)	Emission Level (dBuV)	Limit (dBuV)	Margin (dB)	Reading Level (dBuV)	Correct Factor (dB)	Detector Type
1	0.157	46.95	79.00	-32.05	37.35	9.60	QP
2	0.157	27.75	66.00	-38.25	18.15	9.60	Average
3	0.163	43.44	79.00	-35.56	33.84	9.60	QP
4	0.163	26.37	66.00	-39.63	16.77	9.60	Average
5	0.185	41.05	79.00	-37.95	31.44	9.61	QP
6	0.185	25.14	66.00	-40.86	15.53	9.61	Average
7	0.357	36.09	79.00	-42.91	26.47	9.62	QP
8	0.357	33.07	66.00	-32.93	23.44	9.62	Average
9	0.559	28.63	73.00	-44.37	19.00	9.64	QP
10	0.559	23.36	60.00	-36.64	13.72	9.64	Average
11	22.811	41.30	73.00	-31.70	31.01	10.29	QP
12	22.811	34.28	60.00	-25.72	23.99	10.29	Average

Remark:

1. "" means this data is the worst margin; "!" means this data is over limit.
2. Emission Level=Reading Level + Correct Factor(Correct Factor=LISN Factor+Cable Loss).
3. Margin=Emission Level-Limit

Model No	MAX BR2	Site	HY-SR09
Test Voltage	AC 120V/60Hz	Test Date	2024-03-13
Test Mode	Mode 1	Engineer	Monica Wu
Phase	Neutral	Temperature (°C)	19
Test Condition	--	Humidity (%RH)	50

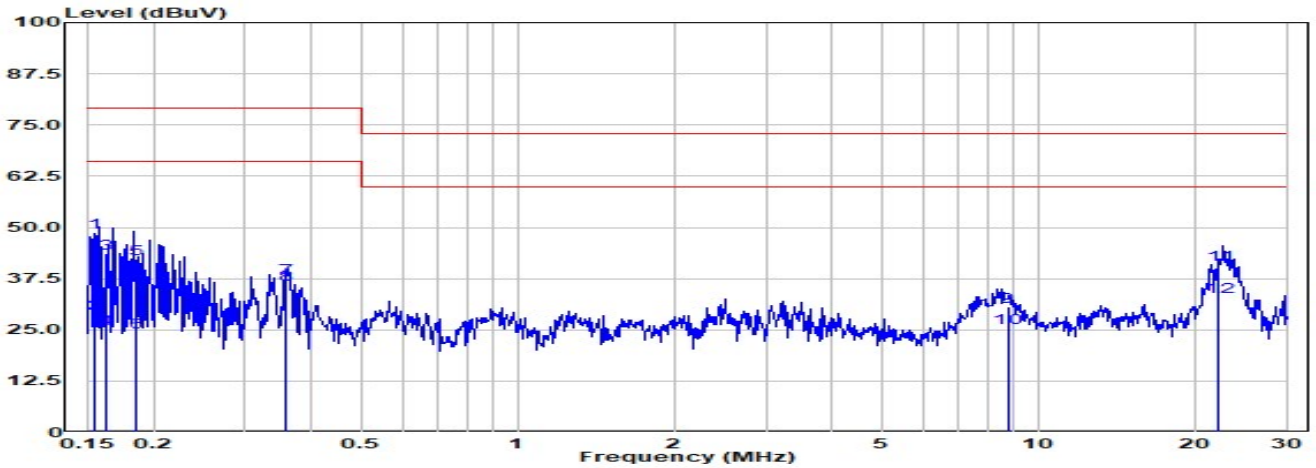

No	Frequency (MHz)	Emission Level (dBuV)	Limit (dBuV)	Margin (dB)	Reading Level (dBuV)	Correct Factor (dB)	Detector Type
1	0.154	48.68	79.00	-30.32	39.04	9.64	QP
2	0.154	28.98	66.00	-37.02	19.34	9.64	Average
3	0.161	43.72	79.00	-35.28	34.07	9.64	QP
4	0.161	25.13	66.00	-40.87	15.49	9.64	Average
5	0.185	42.40	79.00	-36.60	32.75	9.64	QP
6	0.185	24.34	66.00	-41.66	14.70	9.64	Average
7	0.360	37.72	79.00	-41.28	28.07	9.65	QP
8	0.360	35.94	66.00	-30.06	26.28	9.65	Average
9	8.741	30.65	73.00	-42.35	20.61	10.03	QP
10	8.741	25.58	60.00	-34.42	15.55	10.03	Average
11	22.295	40.93	73.00	-32.07	30.48	10.44	QP
12	22.295	33.16	60.00	-26.84	22.71	10.44	Average

Remark:

1. "" means this data is the worst margin;"!" means this data is over limit.
2. Emission Level=Reading Level + Correct Factor(Correct Factor=LISN Factor+Cable Loss).
3. Margin=Emission Level-Limit

4. Radiated Emission

4.1. Test Specification

According to Standard : FCC Part 15 Subpart B & CISPR 22

4.2. Test Setup

Under 1GHz Test Setup:

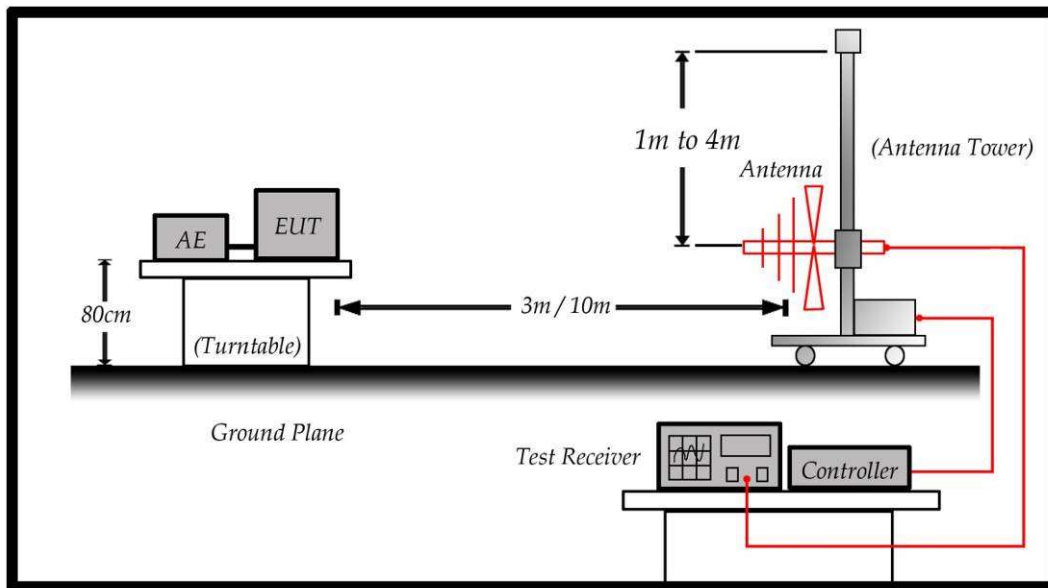

Above 1GHz Test Setup:

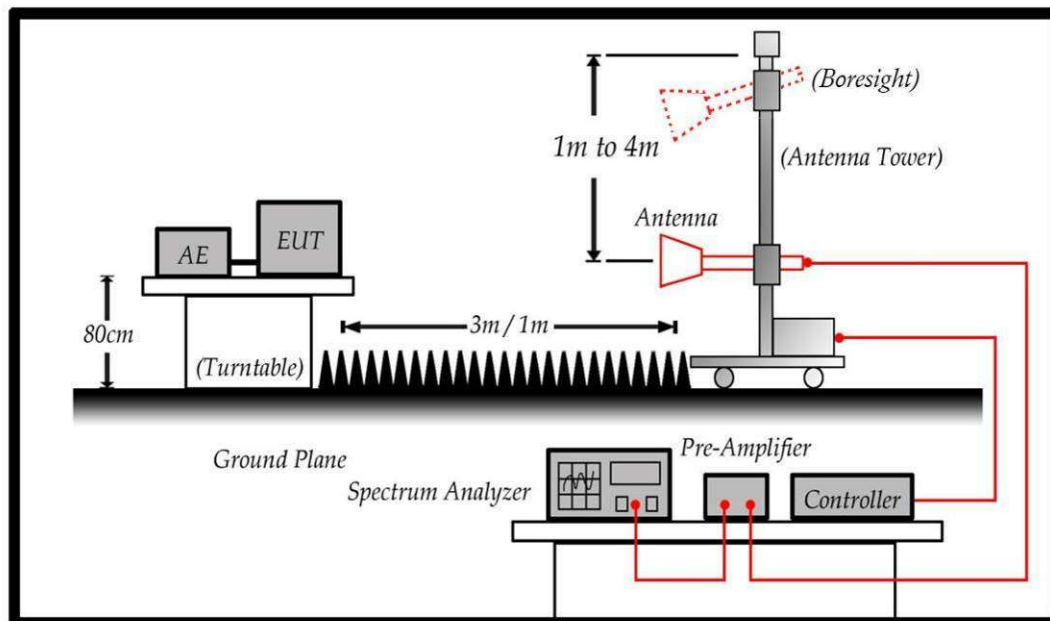

4.3. Limit

Test shall not exceed the following value:

FCC Part 15 Subpart B Paragraph 15.109 Limits (dBuV/m)		
Frequency (MHz)	Distance(m)	dBuV/m
30-88	10	39
88-216	10	43.5
216-960	10	46.4
960-1000	10	49.5
1000-40000	3	60
18000-40000	1	69.5

Remark:

1. The tighter limit shall apply at the edge between two frequency bands.
2. Distance refers to the distance in meters between the measuring instrument antenna and the closed point of any part of the device or system.
3. $RF\ Voltage\ (dBuV/m) = 20\ \log\ RF\ Voltage\ (\mu V/m)$

4.4. Test Procedure

The EUT and its simulators are placed on a turn table which is 0.8 meter above ground.

The turn table can rotate 360 degrees to determine the position of the maximum emission level and the antenna (boresight antenna tower) can move up and down between 1 meter and 4 meters to find out the maximum emission level.

Both horizontal and vertical polarization of the antenna are set on measurement. In order to find the maximum emission, all of the interface cables must be manipulated on radiated measurement.

For an unintentional radiator, including a digital device, the spectrum shall be investigated from the lowest radio frequency signal generated or used in the device, without going below the lowest frequency for which a radiated emission limit is specified, up to the frequency shown in the following table:

Highest frequency generated or used in the device or on which the device operates or tunes (MHz)	Upper frequency of measurement range (MHz)
Below 1.705	30
1.705 – 108	1000
108 – 500	2000
500 – 1000	5000
Above 1000	5 th harmonic of the highest frequency or 40 GHz, whichever is lower

On any frequency or frequencies below or equal to 1000MHz, the radiated limits shown are based on measuring equipment employing a quasi-peak detector function and above 1000MHz, the radiated limits shown are based measuring equipment employing an average detector function.

When average radiated emission measurement are included emission measurement Above 1000MHz, there also is a limit on the radio frequency emissions, as measured using instrumentation with a peak detector function, corresponding to 20 dB above the maximum permitted average limit.

For class A, the measurement distance between the EUT and antenna is 10 meters for under 1GHz and above 1GHz.

For class B, the measurement distance between the EUT and antenna is 10 meters for under 1GHz and 3 meters for above 1GHz.

The bandwidth below 1GHz setting on the field strength meter (Test Receiver) is 120 kHz and above 1GHz is 1MHz.

4.5. Test Result

Model No	MAX BR2	Site	FS-CB01
Test Voltage	DC 10V	Test Date	2024-03-16
Test Mode	Mode 2	Engineer	Nilk Chen
Polarity	Horizontal	Temperature (°C)	23.3
Test Condition	--	Humidity (%RH)	67

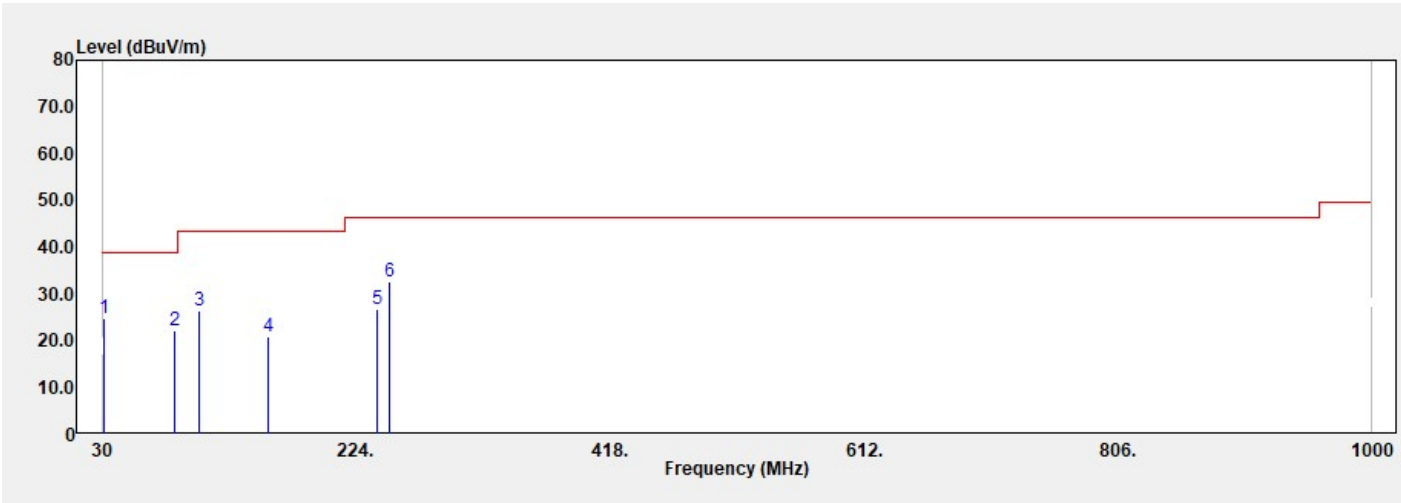

No	Frequency (MHz)	Emission Level (dBuV/m)	Limit (dBuV/m)	Margin (dB)	Reading Level (dBuV)	Correct Factor (dB/m)	Ant Pos (cm)	TT Pos (deg)	Detector Type
1	32.195	24.80	39.00	-14.20	49.52	-24.72	200	83	QP
2	85.286	22.11	39.00	-16.89	51.11	-28.99	400	296	QP
3	103.860	26.48	43.50	-17.02	53.42	-26.94	400	298	QP
4	157.189	20.76	43.50	-22.74	43.40	-22.64	300	223	QP
5	240.072	26.79	46.40	-19.61	50.57	-23.78	400	336	QP
6*	250.076	32.58	46.40	-13.82	56.08	-23.50	400	156	QP

Remark:

1. "*" means this data is the worst margin; "!" means this data is over limit.
2. Emission Level=Reading Level + Correct Factor(Correct Factor=Ant Factor+Cable Loss-Pre Amp).
3. Margin=Emission Level - Limit.

Model No	MAX BR2	Site	FS-CB01
Test Voltage	DC 10V	Test Date	2024-03-16
Test Mode	Mode 2	Engineer	Nilk Chen
Polarity	Vertical	Temperature (°C)	23.3
Test Condition	--	Humidity (%RH)	67

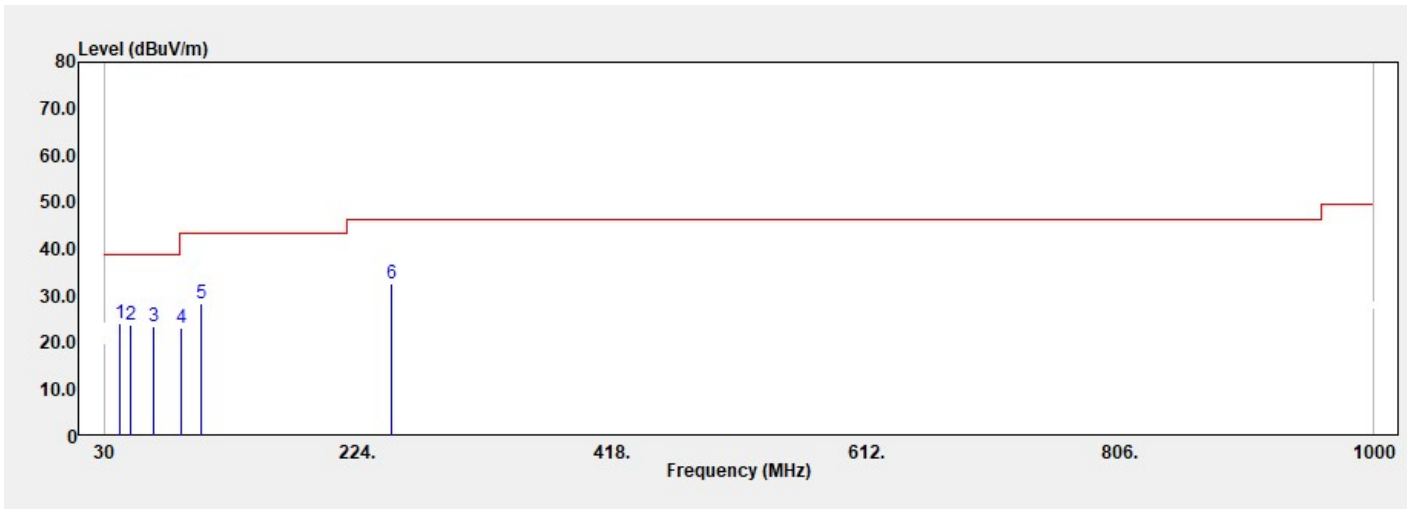

No	Frequency (MHz)	Emission Level (dBUV/m)	Limit (dBUV/m)	Margin (dB)	Reading Level (dBUV)	Correct Factor (dB/m)	Ant Pos (cm)	TT Pos (deg)	Detector Type
1	42.380	24.03	39.00	-14.97	47.01	-22.98	100	281	QP
2	49.975	23.96	39.00	-15.04	46.46	-22.50	100	33	QP
3	68.212	23.39	39.00	-15.61	47.98	-24.58	100	232	QP
4	89.010	23.05	43.50	-20.45	51.58	-28.53	100	254	QP
5	104.524	28.51	43.50	-14.99	54.85	-26.34	100	176	QP
6*	250.075	32.57	46.40	-13.83	55.58	-23.01	200	95	QP

Remark:

1. "*" means this data is the worst margin;"!" means this data is over limit.
2. Emission Level=Reading Level + Correct Factor(Correct Factor=Ant Factor+Cable Loss-Pre Amp).
3. Margin=Emission Level - Limit.

Model No	MAX BR2	Site	HY-CB05
Test Voltage	DC 10V	Test Date	2024-03-12
Test Mode	Mode 2	Engineer	Monica Wu
Polarity	Horizontal	Temperature (°C)	19
Test Condition	--	Humidity (%RH)	59

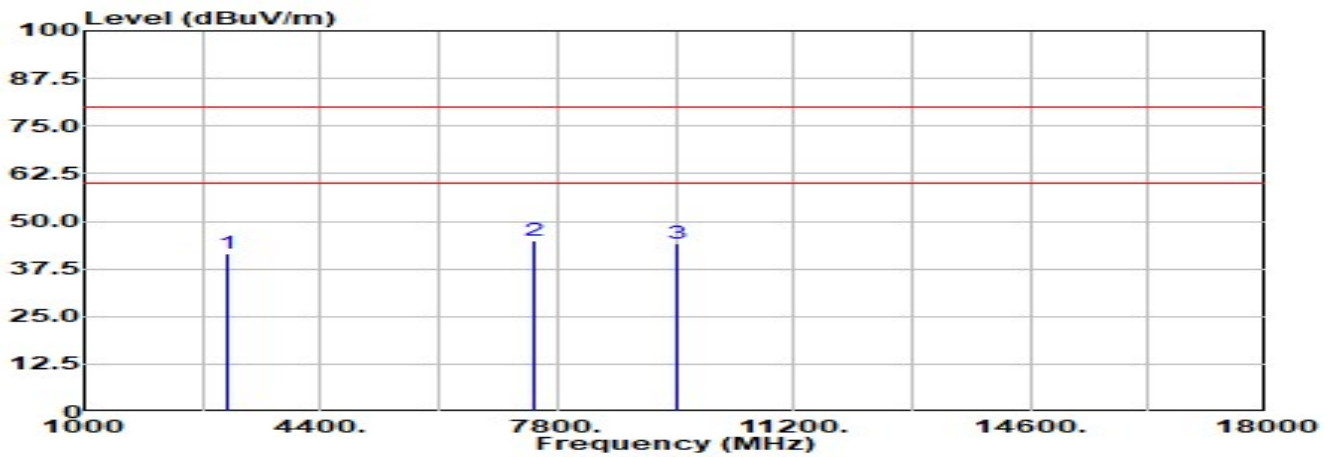

No	Frequency (MHz)	Emission Level (dBuV/m)	Limit (dBuV/m)	Margin (dB)	Reading Level (dBuV)	Correct Factor (dB/m)	Ant Pos (cm)	TT Pos (deg)	Detector Type
1	3057.000	41.59	80.00	-38.41	51.97	-10.38	100	311	Peak
2	7465.667	44.87	80.00	-35.13	44.58	0.29	100	303	Peak
3	9511.333	44.12	80.00	-35.88	41.70	2.42	100	77	Peak

Remark:

1. "*" means this data is the worst margin;"!" means this data is over limit.
2. Emission Level=Reading Level + Correct Factor(Correct Factor=Ant Factor+Cable Loss-Pre Amp).
3. Margin=Emission Level - Limit.

Model No	MAX BR2	Site	HY-CB05
Test Voltage	DC 10V	Test Date	2024-03-12
Test Mode	Mode 2	Engineer	Monica Wu
Polarity	Vertical	Temperature (°C)	19
Test Condition	--	Humidity (%RH)	59



No	Frequency (MHz)	Emission Level (dBuV/m)	Limit (dBuV/m)	Margin (dB)	Reading Level (dBuV)	Correct Factor (dB/m)	Ant Pos (cm)	TT Pos (deg)	Detector Type
1	3289.333	47.49	80.00	-32.51	57.84	-10.35	100	17	Peak
2	7448.667	44.76	80.00	-35.24	44.45	0.31	100	228	Peak
3	11727.000	46.79	80.00	-33.21	41.27	5.52	100	147	Peak

Remark:

1. "*" means this data is the worst margin;"!" means this data is over limit.
2. Emission Level=Reading Level + Correct Factor(Correct Factor=Ant Factor+Cable Loss-Pre Amp).
3. Margin=Emission Level - Limit.

Model No	MAX BR2	Site	HY-CB05
Test Voltage	DC 10V	Test Date	2024-03-12
Test Mode	Mode 2	Engineer	Monica Wu
Polarity	Horizontal	Temperature (°C)	19
Test Condition	--	Humidity (%RH)	59

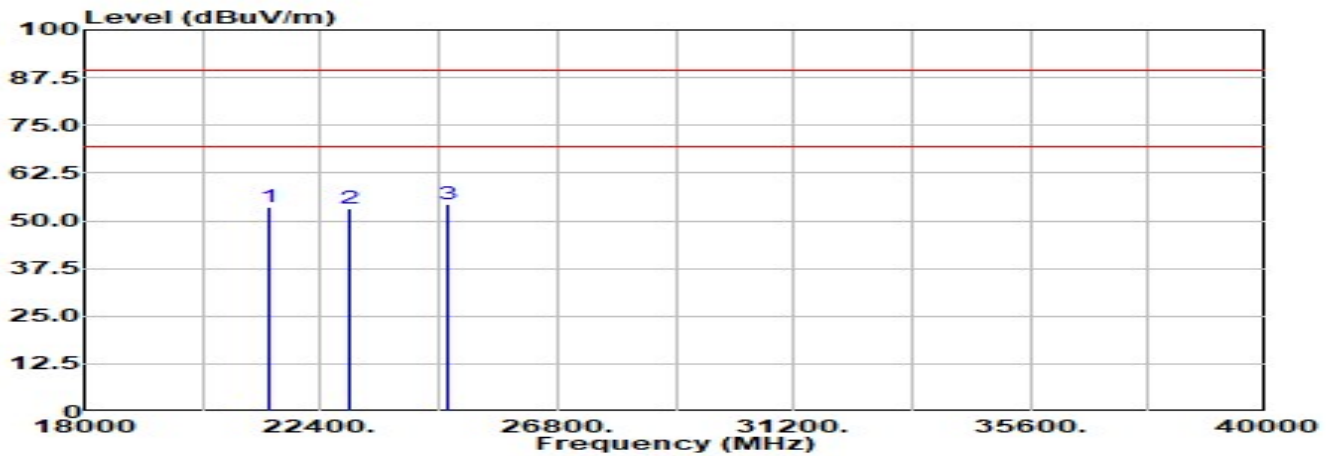

No	Frequency (MHz)	Emission Level (dBuV/m)	Limit (dBuV/m)	Margin (dB)	Reading Level (dBuV)	Correct Factor (dB/m)	Ant Pos (cm)	TT Pos (deg)	Detector Type
1	21459.500	53.54	89.50	-35.96	42.67	10.87	100	8	Peak
2	22933.500	53.11	89.50	-36.39	41.01	12.10	100	339	Peak
3	24776.000	54.16	89.50	-35.34	41.29	12.87	100	354	Peak

Remark:

1. "*" means this data is the worst margin;"!" means this data is over limit.
2. Emission Level=Reading Level + Correct Factor(Correct Factor=Ant Factor+Cable Loss-Pre Amp).
3. Margin=Emission Level - Limit.

Model No	MAX BR2	Site	HY-CB05
Test Voltage	DC 10V	Test Date	2024-03-12
Test Mode	Mode 2	Engineer	Monica Wu
Polarity	Vertical	Temperature (°C)	19
Test Condition	--	Humidity (%RH)	59

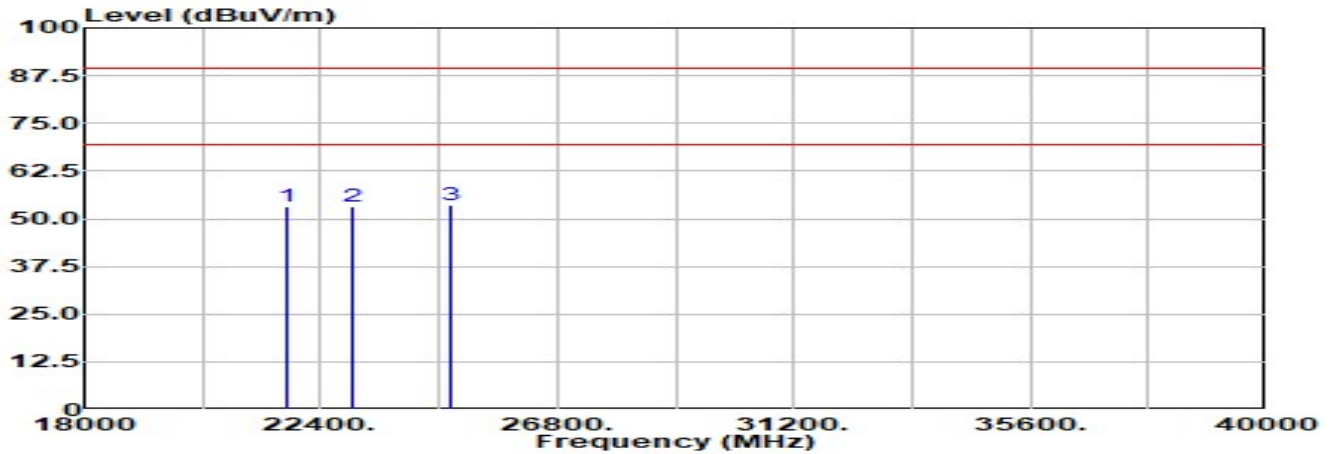

No	Frequency (MHz)	Emission Level (dBuV/m)	Limit (dBuV/m)	Margin (dB)	Reading Level (dBuV)	Correct Factor (dB/m)	Ant Pos (cm)	TT Pos (deg)	Detector Type
1	21789.500	53.09	89.50	-36.41	41.68	11.40	100	181	Peak
2	22988.500	53.30	89.50	-36.20	40.99	12.31	100	344	Peak
3	24825.500	53.60	89.50	-35.90	40.63	12.97	100	38	Peak

Remark:

1. "*" means this data is the worst margin;"!" means this data is over limit.
2. Emission Level=Reading Level + Correct Factor(Correct Factor=Ant Factor+Cable Loss-Pre Amp).
3. Margin=Emission Level - Limit.