

Dongguan Pan Asia electronics Co., LTD

Room 202, Building 1, No. 194, Shijie Technology East Road, Shijie Town, Dongguan City, Guangdong Province

SPECIFICATION FOR APPROVAL

客 户: _____
 CUSTOMER: _____

客 户 料 号: _____
 CUST P/N: _____

产 品 料 号: 0.08*48P
 FINE P/N: _____

产 品 型 号: 6.3UH10%\43.5*.20.5*0.6 Slotted back glue Outlet length
 DESC: _____

日 期: **2023/07/26**
 DATE: _____

版 本: _____
 Version: _____

制作 PREPARED BY	审核 CHECKED BY	批准 APPROVED BY	客户承认 CUSTOMER APPROVE

SPECIFICATION

产品型号:
DESC

Φ43.5x20.5-10Ts-0.08x48P-30mm

版本

Rev: A.0

客户 CUST:

料号 Fine P/N:

客户料号 CUST P/N:

331

FYD331003

A11

一、尺寸 DIMENSION:(mm)

二、原理图 SCHEMATIC DIAGRAM:

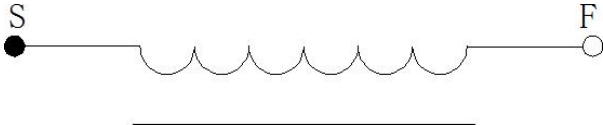

三、绕线参数 Winding Specification:

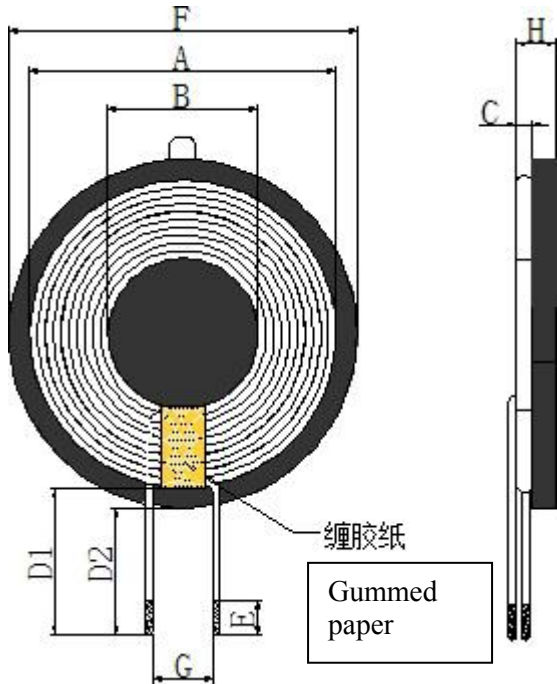

- A 40±0.5
- B 20±0.5
- C 0.6thickness
- D1 14mm±2
- D2 12mm±2
- F 43.6±0.2
- G 8.0 ref
- H 1.6±1
- I 5.3 ref
- E 3±0.2

Note:

1. Coil attached magnetic disc, magnetic disc size 43.5±0.2mm, thickness is 0.6
2. Wrap 8mm(ref) width high-temperature adhesive paper 1-2Ts around the coil outlet position;
3. Stick a circular diameter on the back of the disc 42mm(ref) white double-sided tape, inner hole 20.5/8.6mm (ref), (must add 3mm double-sided tape with hole).

序号 NO.	端子 TERMINAL		线径 WIRE	圈数 Turns	绕线方向 Winding Direction
1	S	F	Bare copper wire 0.08*48P	11Ts	CCW

四、电气特性 ELECTRICAL CHARACTERISTICS:

温度 TEMPERATURE:25±10°C, 湿度 RELATIVE HUMIDITY:75±20%

序号 NO.	项目 ITEM	端子 TERMINAL	标准 SPECIFICATION	测试条件 TEST FREQUENCY	测试仪器 TEST EQUIPMENTS
1	IND.	S-F	5.4uH ±15%Individual coil	100KHz/1.0V	LCZ METER 1062B
2	IND.	S-F	6.5uH ±15%Magnetized sheet	100KHz/1.0V	LCZ METER 1062B
3	DCR	S-F	≤50mΩ		LCZ METER 502B

拟制/日期 PREPARED BY/DATE

2023/7/26

审核/日期 CHECKED BY/DATE

2023/7/26